



Features

- Single axis precision angle measurement
- Output fully conditioned offering a complete stand alone measurement system
- Ranges $\pm 1^\circ$ to $\pm 90^\circ$
- Extremely rugged (withstands 1500g shock)
- Measurement resolution down to 0.1 arc seconds
- Analogue output 4-20mA
- Sealed connector, solder pin or wired outputs
- Silicone oil and electrical damping
- Highly stable over time and temperature



Description

The LSOX Series Inclinometer is a rugged, high performance, single-axis tilt sensor designed for peak performance in extreme conditions. The fluid damped mechanism delivers superior noise rejection in high shock and vibration environments as well as excellent output stability over both time and temperature. Units are available with 6-pin connector, pin-terminals, or flying leads. The output is an industry standard 4-20mA, although other versions include +/-5V and 0-5V. Custom ranges and filters are also available on request.

Applications

- Radar levelling and monitoring
- High accuracy levelling systems
- Satellite antenna platform levelling
- Semiconductor wafer handling systems
- Surface flatness inspection measurement systems
- High precision structural monitoring
- Pavement profiling rigs
- Rail maintenance equipment

Pin Connection for LSOX

Connector Model

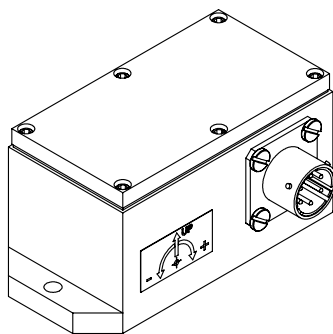

Pin Ref	Function
A	+ve Supply (20 to 30V)
B	GND (0V)
C	NC
D	Output (4-20mA)
E	NC
F	NC

Pin Model

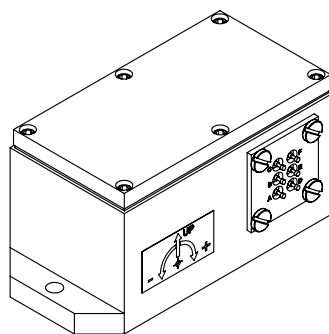

Pin Ref	Function
A	+ve Supply (20 to 30V)
B	GND (0V)
C	NC
D	Output (4-20mA)
E	NC
F	NC

Wired Model

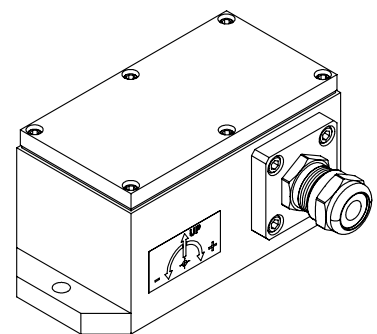

Wire Colour	Function
Red	+ve Supply (20-30V)
White	GND (0V)
Black	NC
Green	Output (4-20mA)



Environmental Characteristics

Operating Temperature Range	°C	-40 to 80
Survival Temperature Range	°C	-60 to 90
Constant Acceleration Overload	g	50
Shock Survival		1500g, 0.5msec, ½ sine
Vibration		20g rms, 20 Hz to 2000 Hz sinusoidal
Environmental Sealing		IP66

Specifications by Range @ 20°C

Range		±1°	±3°	±14.5°	±30°	±90°
Supply Voltage	Volts dc			20 to 30		
Current Consumption	mA (max)	40	40	40	40	40
Full Range Output (FRO) (see note 1)	mA			4-20		
Output Noise	µA rms (max)			0.002		
Non-Linearity (see note 2)	% FRO (max)	0.05	0.02	0.02	0.02	0.05
Resolution (see note 3)	arc seconds	0.2	0.4	1.0	2.0	4.0
Bandwidth (-3dB)	Hz	0.5	2	15	20	30
Sensitive Axis-to-Case Misalignment	deg (max)	±0.25	±0.25	±0.5	±0.5	±0.5
Zero Offset Error (see note 4)	mA (max)	±0.6	±0.6	±0.3	±0.3	±0.3
Thermal Zero Offset Shift	mA/°C (max)	0.024	0.010	0.002	0.001	0.0008
Scale Factor Thermal Sensitivity	PPM/°C (max)	350	300	100	60	60

Notes

1. Full Range Output is defined as the full angular excursion from positive to negative, i.e. ±90° = 180°
2. Non-linearity is specified as deviation of output referenced to theoretical sine function value, independent of misalignment
3. Full Resolution is achieved with noise reduction techniques
4. Zero offset is specified under static conditions with no vibration inputs

Ordering Information

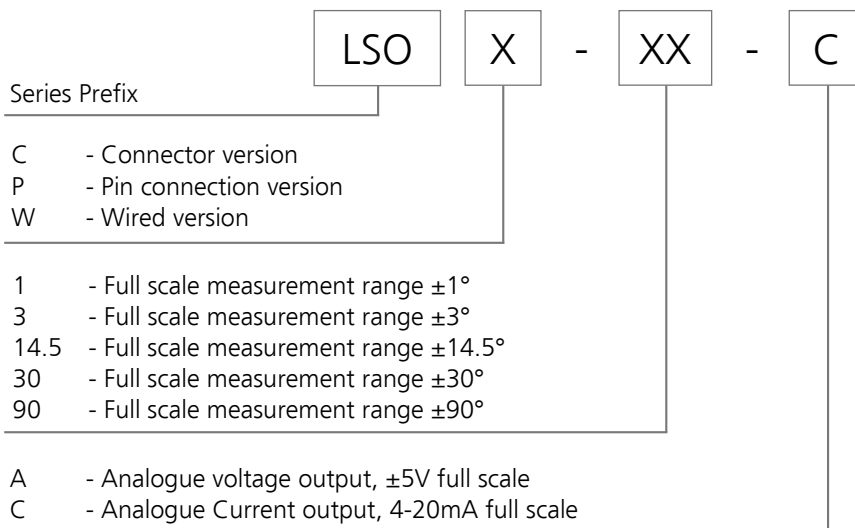

Example:

LSOC-14.5-C

LSO Series single axis closed loop inclinometer sensor.
Connector type model
±14.5° Full Scale Measurement Range
Analogue current output, 4-20mA



Dimension Drawing - Connector Type

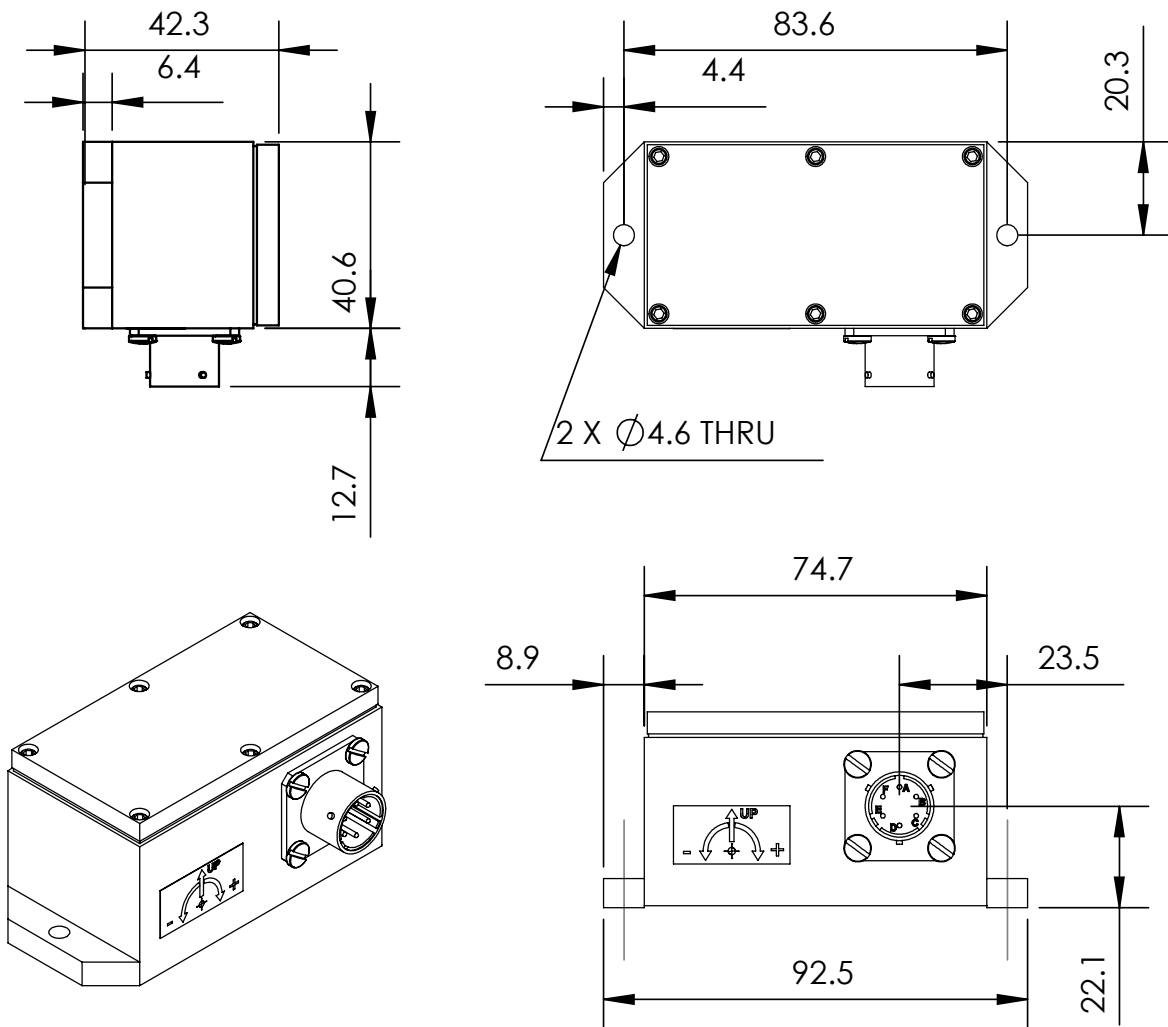

Cables and Connectors

The connector version of this product uses a sealed bayonet type locking Mil-Spec 6 way connector. The connectors and standard cables can be purchased directly from us (see below), and we also can supply customised cable assemblies for this product.

Mating Connector



Part No : LSO-CONN

2m PUR Cable and Mating Connector

Part No : EL-CAB-LSO-CONN-2

5m PUR Cable and Mating Connector

Part No : EL-CAB-LSO-CONN-5



Dimension Drawing - Pin Type

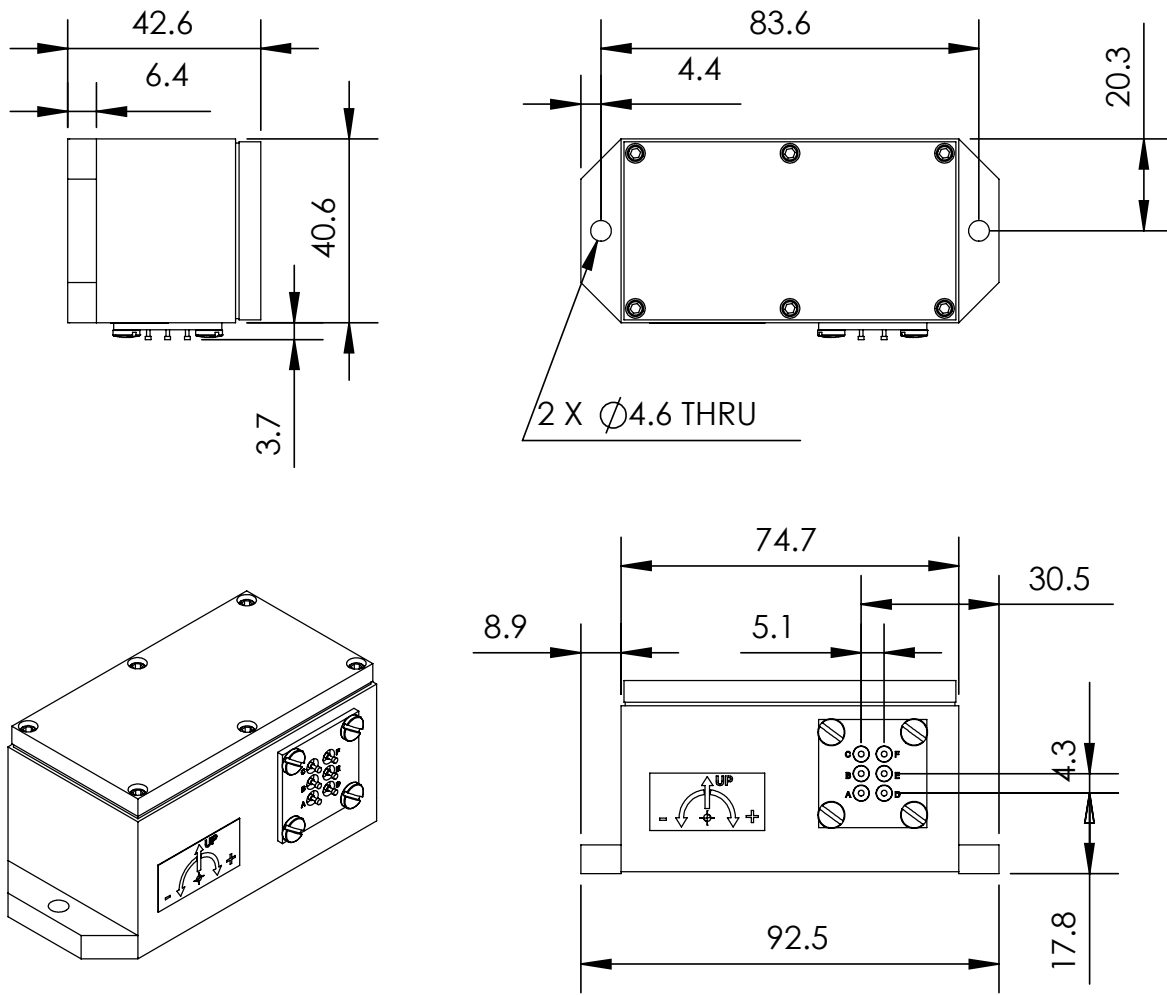

Axis Direction and Mounting Orientation

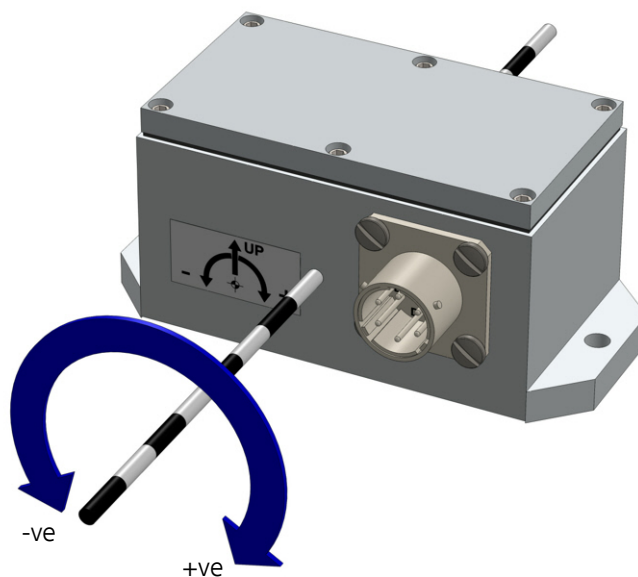



Dimension Drawing - Wired Type

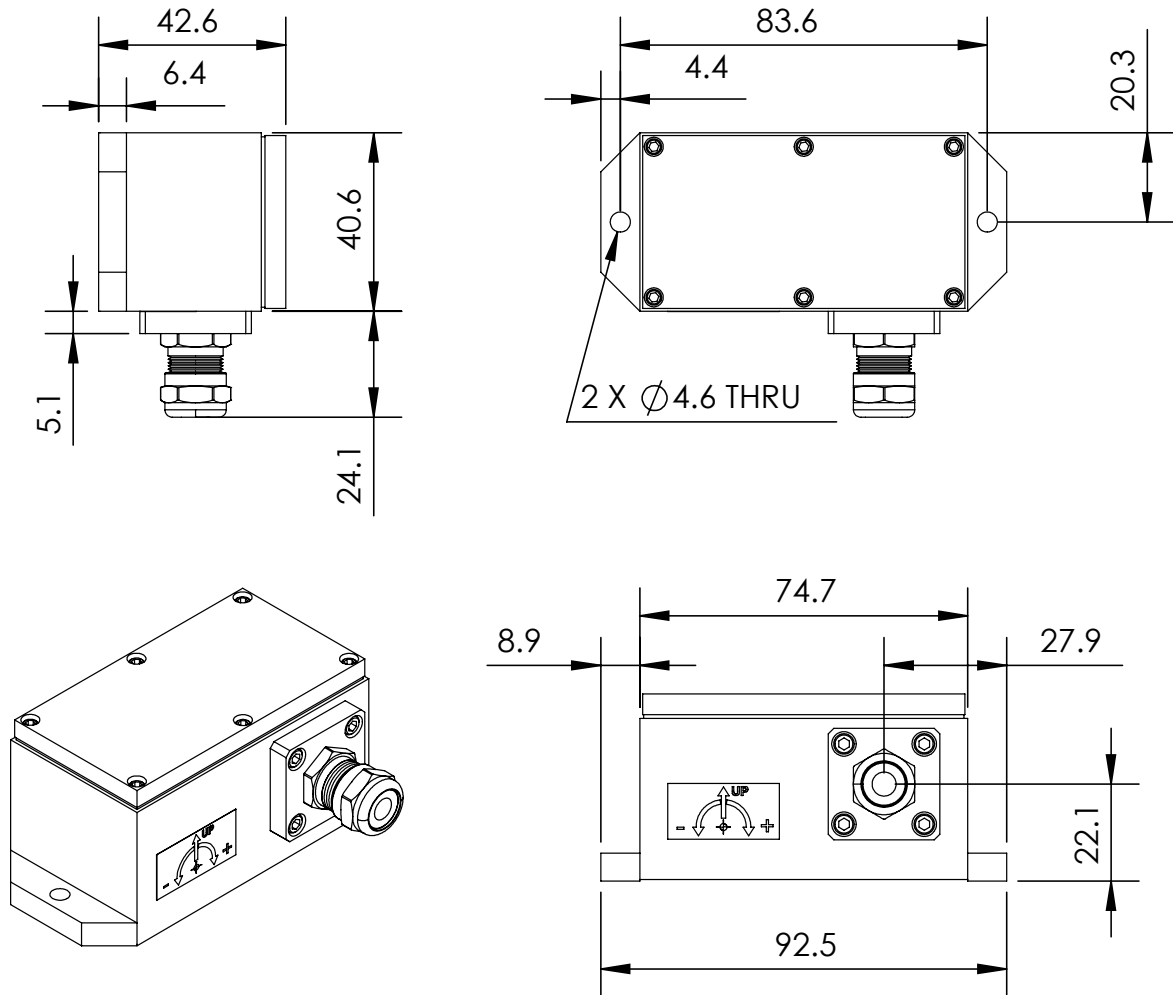



Voltage Output Change With Angle

As the LSO sensor is rotated the sensing element is subject to gravitational acceleration which exerts force on the proof mass. The proof mass is attached to a torquer mechanism in a closed loop configuration. A feedback current is applied to the torquer mechanism to maintain the mass in a positional equilibrium. The amount of feedback current is proportional to the acceleration (due to gravity) acting on the mass, and this current is converted and scaled to 4-20mA at the output stage. As such, the output from the sensor is linear with the change in acceleration (g), which means that the output is a sine function of the change in angle (°). Please see the graph below for the output of an LSO with a ±90° full scale range.

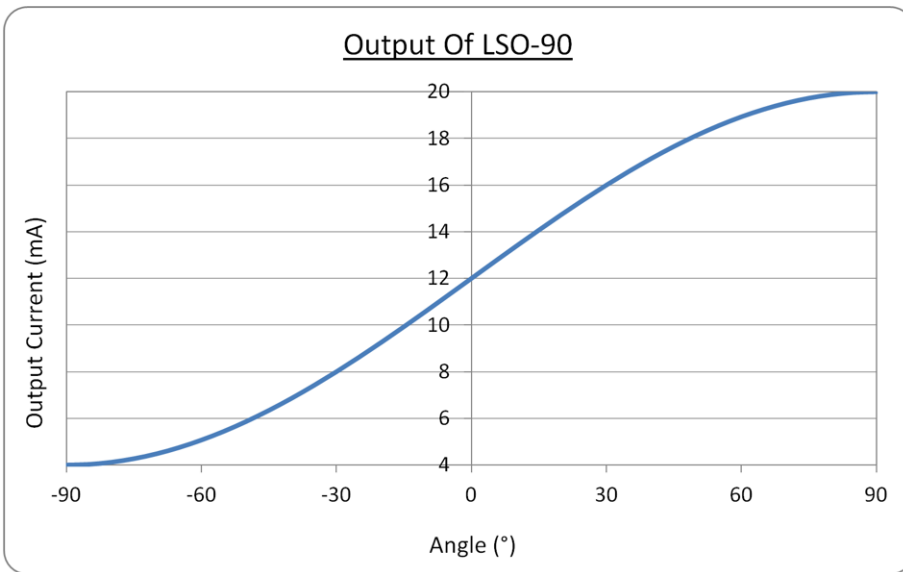

Because of the shape of the sine curve, the output is very linear around the zero position, for example at ±3° the sine non linearity would only introduce an error of 0.0005°, so for small angular ranges it is reasonable to consider the output as linear. For larger angles it is necessary to use an arcsine function to derive the angle (see below). As the angle approaches 90° the sensitivity of the sensor drops significantly making measurements up to the full 90 degree range much less accurate.

$$Angle = \sin^{-1}\left(\frac{I_{out} - 12}{ScaleFactor}\right)$$

Where:

Angle is the angle of tilt of the sensor

Iout is the measured current from the output of the sensor

Scale Factor depends on the full scale measurement range of the sensor, see table below:

Full Scale Range	Scale Factor (mA / g)
±1°	458.39
±3°	152.86
±14.5°	31.95
±30°	16
±90°	8