



Features

- Single, dual or omni-directional tilt sensing
- Adjustable switching threshold from 1 to 50°
- 'ZERO' button to set zero after installation
- Small size and low power consumption
- No moving parts means no servicing and long life
- High precision switching threshold
- Mercury free and RoHS compliant
- Sealed to IP65 / IP67 and CE Certified
- Highly configurable to suit most applications
- Relay output contacts for total isolation

Applications

- Bank angle warning system for ride-on lawn mowers.
- Safety cut-out for cranes with hydraulic levelling
- Tilt warning system for platform and hoist levelling.
- Rollover warning system for agricultural vehicles
- Safety cut-out for aerial work platforms
- Can be readily customised to suit most applications



ETS M - Anodised Aluminium Housing



ETS - ABS Housing

Description

A highly configurable tilt switch that is factory configured as either single axis, dual axis or omni-directional tilt threshold sensing. For each of these types there are four versions to cover a variety of switching angles. The exact switching angle can be adjusted with the PCB mounted rotary switches.

With the dual axis version the tilt threshold (the trip angle) can be adjusted individually for the X and Y axis. With the single axis version, only the X axis is monitored, and with the omni-directional version, the measurement of both axis is combined to calculate the resultant tilt angle, and the switch will operate if the threshold angle is exceeded in any direction of tilt.

Once the tilt threshold is reached the relay operates and the switch contacts are closed. This can be used to

sound an alarm, switch on a warning light, or interface directly to a machines control system.

The device is available with either an ABS housing, or a robust compact Anodised Aluminium housing designed for harsh operating environments.

The devices have a highly accurate and repeatable switching threshold, and built in analogue and digital noise filtering to reduce the effects of vibration.

Standard models are readily available from stock, but they are highly factory configurable and can be supplied with custom options to suit most OEM requirements (see page 5).

All of these devices are manufactured, calibrated and tested in our UK factory to ensure compliance with the stated specification.



Specifications

Part Number	ETS 1-4	ETS 4-11.5	ETS 10-25	ETS 20-50	Notes
Switching Range	1-4°	4-11.5°	10-25°	20-50°	Range is adjustable via the 16 position PCB rotary switch
Adjustment Step	0.2°	0.5°	1°	2°	Adjustment resolution of the rotary switch
Switching Accuracy	±0.1°	±0.2°	±0.5°	±1°	Switching Accuracy at 20°C
Hysteresis †	0.2°	0.5°	1°	2°	The angle between the switch on and switch off position. Necessary to prevent oscillation at the threshold
Bandwidth (-3dB)	0.5Hz				Frequency response. (Can be factory configured between 0.125 and 16Hz on request)
Power Supply	9-32Vdc				Low noise dc supply should be used
Current (relay off)	4-8mA				Current varies with supply voltage
Current (relay on)	20-40mA				Current varies with supply voltage
Switching Capacity	220Vdc, 250Vac, 50W max, 2A max				Large switching currents will reduce the relay contact life
Dimensions	65 x 60 x 40mm (ABS housing) 76 x 44 x 20mm (Aluminium Housing)				
Operational Temperature	-40 to 85°C				
Storage Temperature	-40 to 85°C				
Sealing	IP65 / IP67				ABS housing: IP65; Metal housing: IP67

Part Numbering

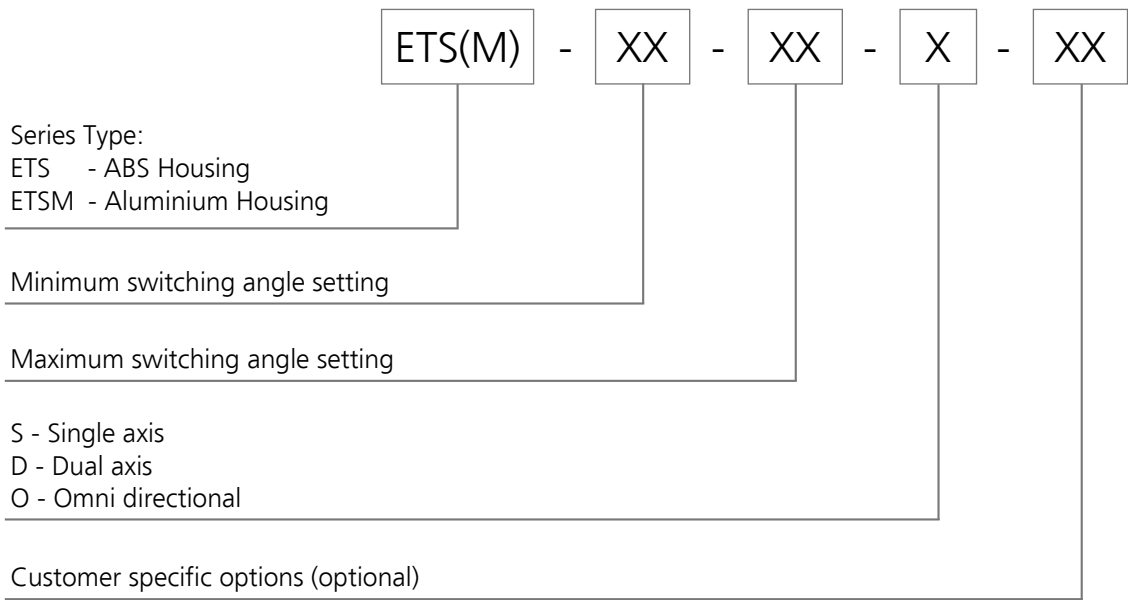

Example 1:
ETS-10-25-D
ABS Housing
Adjustable switching range : 10 to 25°
Dual axis

Example 2:
ETSM-1-4-S
Anodised Aluminium Housing
Adjustable switching range : 1 to 4°
Single axis



Housing Drawing (ABS)

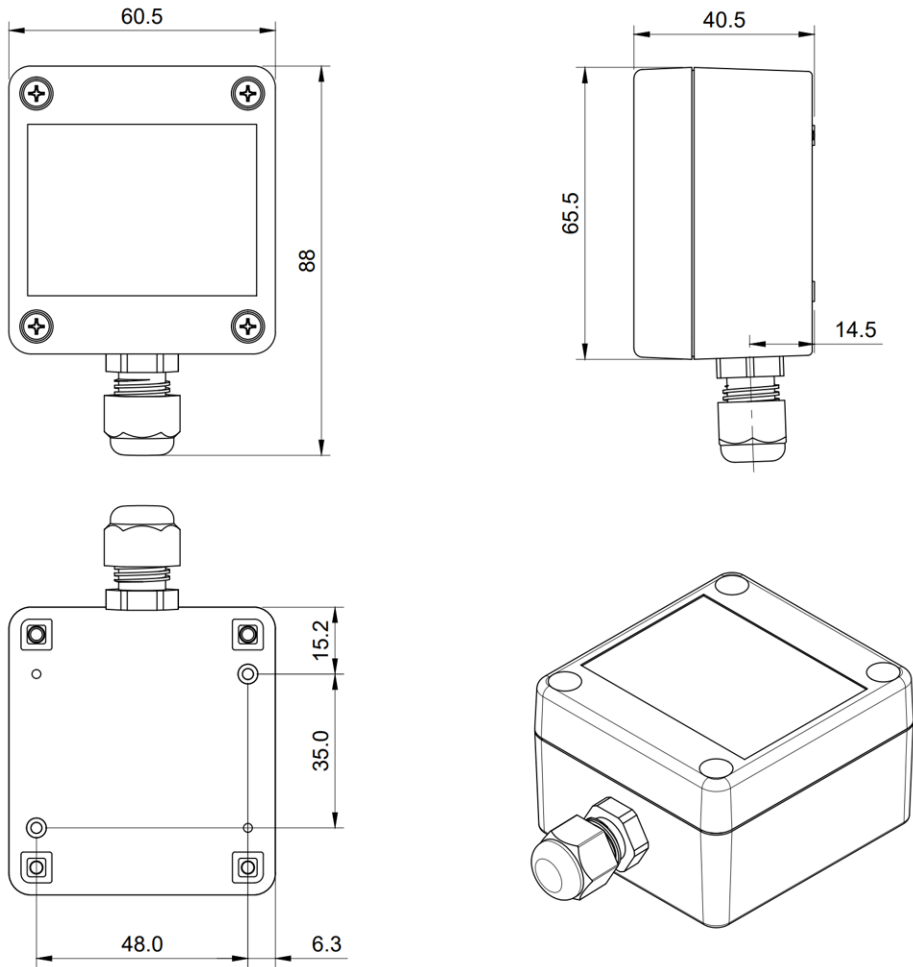

Axis Direction





Housing Drawing (Anodised Aluminium)

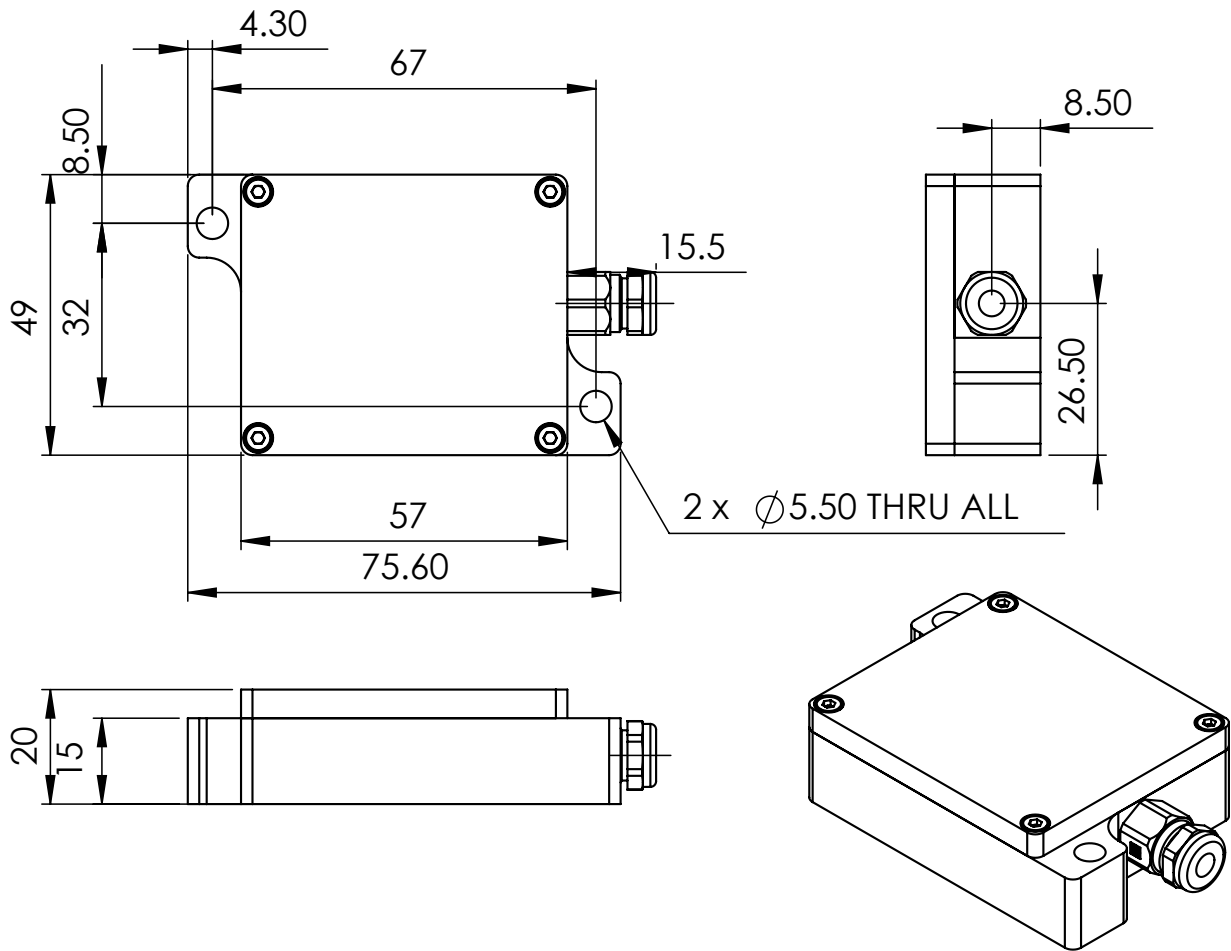

Axis Direction

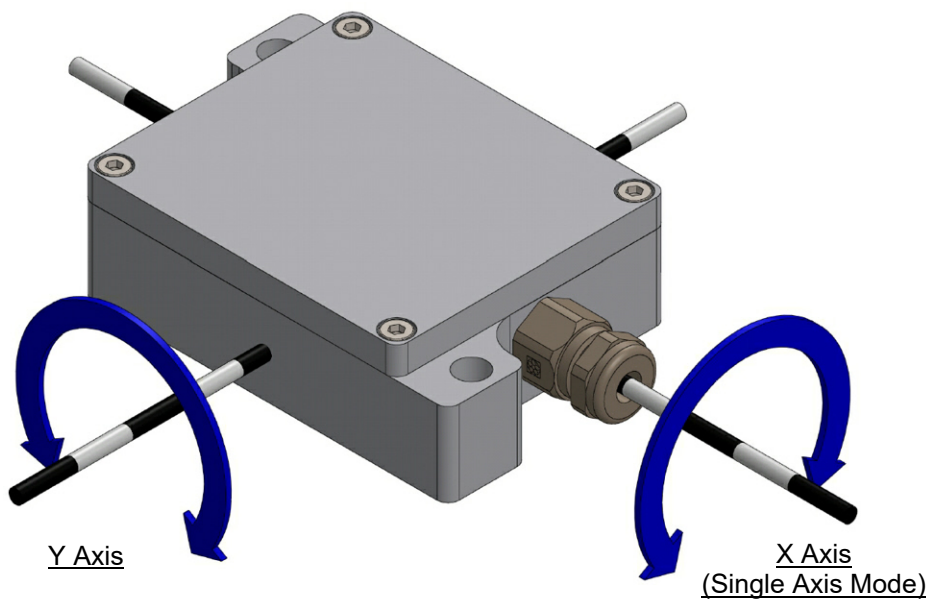

**Cable Details**

1. Standard length : 2m (others on request)
2. Core wires, tin plated copper, 7x0.2mm strands per conductor (24 AWG). 5 conductors colours brown, green, yellow, grey and white. PVC core insulation.
3. Braided screen of tin copper wire with minimum 85% coverage.
4. PVC dark grey outer jacket
5. Approvals: UL AWM Style 2464
CSA AWM I/A4II A

Wire Colour	Terminal Block Pin	Function
Brown	5	+Ve Supply
Green	4	GND
Yellow	3	Normally closed relay contact
Grey	2	Normally open relay contact
White	1	Relay Common

Parameter	Value	Unit	Notes
Approximate Weight	51	g/m	
Operating Temperature	-40 to 80	°C	
Conductor Resistance	100	Ω/Km	Maximum resistance
Test Voltage	1.5	KV DC	
Voltage Rating	300	V	
Core Current Rating	2	A	At 40°C air temperature
Individual Core Diameter	1.25	mm	
Overall Diameter	5.5	mm	

Certification

The products are type approved to in accordance with the following directive(s):

EMC Directive 2004/108/EC



And it has been designed, manufactured and tested to the following specifications:

BS EN61326-1:2006

Electrical equipment for measurement, control and laboratory use
– EMC Requirements

BS EN55011:2007, Group 1
Class B

Certification is available on request.

Product Options

For OEM customers with on-going or volume requirements the device can be customised in a number of different ways:

1. Standard cable length 2m other lengths supplied on request
2. Standard cable supplied with bare ends, stripped and tinned. Connector versions available:
 - a. M12 x 5 (male or female)
 - b. TE Superseal
 - c. Deutsch DT04
 - d. Others on request
3. Preset switching thresholds (not user adjustable)
4. Different switching thresholds for X and Y axis, and for positive and negative tilt directions
5. Modified digital filtering to match the application dynamics
6. Factory configurable delay between threshold reached and switch activated
7. Alternate mounting orientations and axis directions
8. Custom labelling and marking



Setting the Zero Position

As supplied, the tilt switch will operate when the threshold angle is reached with respect to an absolute level plane.

If however the unit is not mounted perfectly horizontally any error can be removed using the zero set switch. This is a small push button switch on the printed circuit board inside the housing.

The maximum off level (horizontal) that can be electronically compensated is ±10° in any direction, however to get the best switching accuracy and to minimise the effect of temperature on the accuracy it should be installed as close as possible to the horizontal plane of the machine or equipment it is being installed on.

The switch is accessible by removing the top cover of the housing by releasing the four screws.

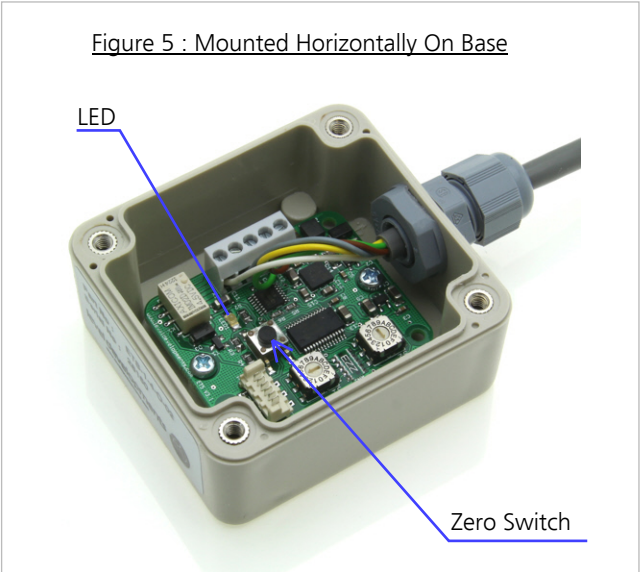

- First ensure the tilt switch is mounted in accordance with the instructions on page 1.
- Position the machine or equipment in a level plane in both axis.
- Remove the top cover of the housing by releasing the 4 screws in the lid.
- Power on the unit. Once the tilt switch is powered on, wait for at least 5 seconds.
- Carefully press the small push button switch on the PCB. This is highlighted in figure 5. Care should be taken not to touch any of the other components on the PCB when pressing this switch. Push the button in and release it, do not hold it pressed down.
- After pressing, the LED on the PCB will blink to indicate that the button press has been successful.

The tilt switch stores this zero position in non volatile memory and uses the value when calculating whether or not the threshold angle has been exceeded. It will remember this even after the power is disconnected and then re-connected.

Wiring Information

The Tilt sensor has a five wire connection. The brown and green wires are used for the power supply and the other wires are connected to the switch contacts. **The unit is not fused internally.** On a vehicle system it should be connected to a supply from the fuse box with a 1A rating, or connected using an inline 1A fuse. Please see the schematic opposite and the table below for connection details.

Wiring Details

Wire Colour	Terminal Block Pin	Function
Brown	5	+ve Supply
Green	4	GND (0V)
Yellow	3	Normally closed relay contact
Grey	2	Normally open relay contact
White	1	Relay Common

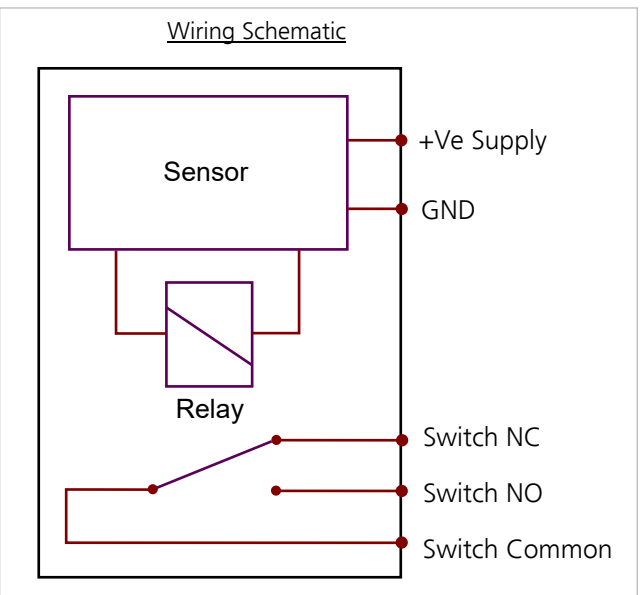



Mounting The Unit

- The unit should be mounted in the horizontal plane.
- It can be mounted base down, or base up (inverted). See figures 1 and 2
- If the unit is not mounted perfectly horizontally any error can be removed after wiring using the zero set switch. See section below titled 'Zero Setting' for more information.
- The maximum off level (horizontal) that can be electronically corrected is $\pm 10^\circ$ in any direction.
- However to get the best switching accuracy and to minimise the effect of temperature on the accuracy it should be installed as close as possible to the horizontal plane of the machine or equipment it is being installed on.
- The unit is mounted via the two holes on the underside of the housing. No. 6 or similar self tapping screws can fix directly into the holes through the mounting plate. See figure 4 for dimension information.
- The blind holes are only 6mm deep so it is very important to use the correct screw length.
- A right angle mounting bracket is available to enable fixing to a vertical surface, part ref ETS-RAB (figure 3).
- We do not recommend the housing is drilled to make new fixing points. Drilling can cause damage to the electronic components, and the box's seal rating will be compromised.

Figure 1 : Mounted Horizontally On Base



Figure 2 : Mounted Horizontally Inverted

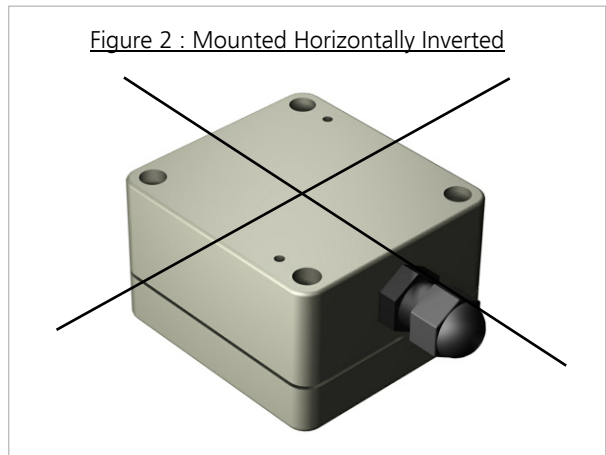

Figure 3 : Right Angle Bracket Mounting

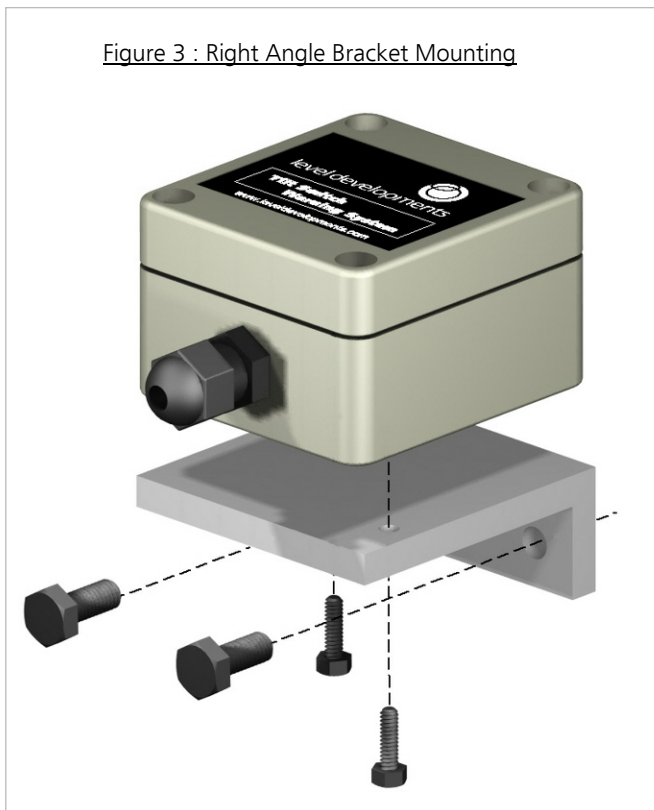
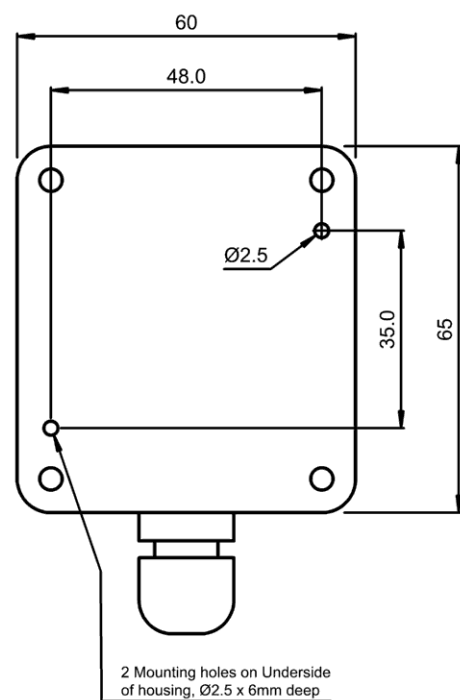

Figure 4 : Mounting Hole Positions





Setting the Tilt Threshold

The tilt threshold can be adjusted to set the angle at which the device will trigger. The range of adjustment will depend on the model purchased (see table). The tilt threshold is set via the small rotary switches on the PCB.

There are two switches, one which sets the tilt threshold in the X axis and one for the Y axis. For single axis and omni-directional models, only the S1 switch is used, and the S2 switch has no function. The switches are labelled S1 and S2 on the PCB (figure 7) and the arrows on this picture indicate the rotational axis which they set. For single axis units, the sensitive axis is the S1 axis. For omni-directional units, the resultant angle from the S1 and S2 axis is measured and compared with the value from the S1 switch.

The rotary switches have 16 positions labelled 0-9 and then A-F. This allows the trip angle to set with a range of 16 values between the maximum and minimum values. Table 2 details the switch position and tilt threshold value for each of the ETS models available. The switches can be adjusted with a small screwdriver.

Once set, the lid should be screwed back in position and the unit is now ready to use. In normal operation the relay will be engaged, and the switch contact closed when the angle is greater than the threshold angle in either or both axis. The relay will switch off when the angle is reduced below the threshold angle less the hysteresis value. The hysteresis is necessary to avoid oscillation at the threshold point. The hysteresis angle varies for each model, for details please consult the product data sheet.

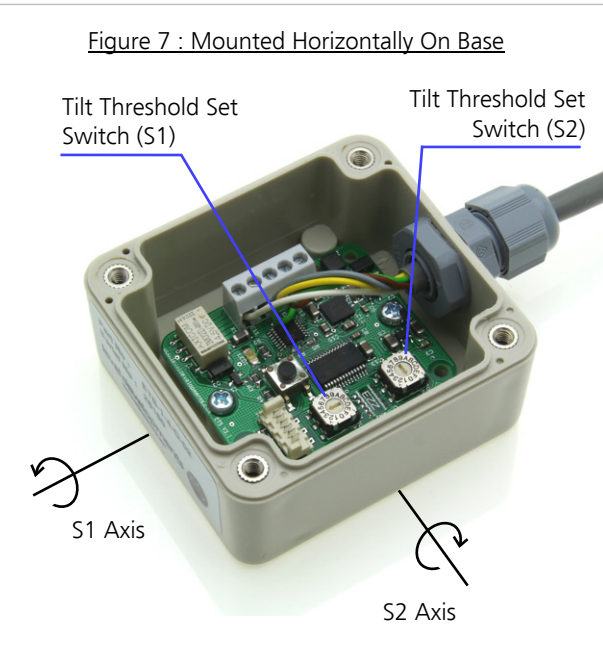

Switch Position	Trip Angle			
	ETS 1-4	ETS 4-11.5	ETS 10-25	ETS 20-50
	1.0°	4.0°	10°	20°
	1.2°	4.5°	11°	22°
	1.4°	5.0°	12°	24°
	1.6°	5.5°	13°	26°
	1.8°	6.0°	14°	28°
	2.0°	6.5°	15°	30°
	2.2°	7.0°	16°	32°
	2.4°	7.5°	17°	34°
	2.6°	8.0°	18°	36°
	2.8°	8.5°	19°	38°
	3.0°	9.0°	20°	40°
	3.2°	9.5°	21°	42°
	3.4°	10.0°	22°	44°
	3.6°	10.5°	23°	46°
	3.8°	11.0°	24°	48°
	4.0°	11.5°	25°	50°