

MANUAL

HighTECH Line | PROTECTION TECHNOLOGY
MADE SIMPLE

MR13-ITE(R) | TIME-OVERCURRENT RELAY WITH THERMAL
REPLICA AND EARTH CURRENT MEASURING



TIME-OVERCURRENT RELAY WITH THERMAL REPLICA AND EARTH CURRENT MEASURING

Original document

English

Revision: B

**SEG Electronics reserves the right to update any portion of this publication at any time.
Information provided by SEG Electronics is believed to be correct and reliable.
However, no responsibility is assumed by SEG Electronics unless otherwise expressly undertaken.**

© SEG Electronics 1994–2020. All rights reserved.

Contents

1.	Introduction and Application	5
2.	Features and characteristics	6
3.	Design	7
3.1	Connections	7
3.1.1	Analogue input circuits	8
3.1.2	Output relays	9
3.2	Relay output contacts	9
3.2.1	Blocking input	10
3.2.2	External reset input	10
3.2.3	Fault recorder	10
3.3	Front plate	12
4.	Working principle	14
4.1	Analog circuits	14
4.2	Digital circuits	14
4.3	Thermal replica	15
4.3.1	Definitions	15
4.4	Algorithm	16
4.5	Earth fault protection	19
4.5.1	Generator stator earth fault protection	19
4.5.2	System earth fault protection	19
4.6	Earth-fault directional feature (ER-relay type)	20
4.7	Demand imposed on the main current transformers	22
5.	Operation and settings	23
5.1	Display	23
5.1.1	LEDs	25
5.2	Setting procedure	27
5.3	System parameter	27
5.3.1	Display of measuring values as primary quantities (I_{prim} phase)	27
5.3.2	Display of earth current as primary quantity (I_{prim} earth)	27
5.3.3	Display of residual voltage U_E as primary quantity ($U_{\text{prim}}/U_{\text{sec}}$)	27
5.3.4	Voltage transformer connection for residual voltage measuring (3pha/e-n/1:1)	27
5.3.5	Nominal frequency	28
5.3.6	Display of the activation storage (FLSH/NOFL)	28
5.3.7	Parameter switch/external triggering of the fault recorder	28
5.4	Protection parameters	29
5.4.1	Pickup value of the thermal overload protection $I_{B,A}$ and $I_{B,T}$	29
5.4.2	Constant k	29
5.4.3	Energizing delay (time) for the thermal overload	29
5.4.4	Time constant τ	29
5.4.5	Pickup current for phase over current element ($I_{>}$)	29
5.4.6	Time current characteristics for phase overcurrent element (CHAR $I_{>}$)	30
5.4.7	Trip delay or time multiplier for phase over current element ($t_{I_{>}}$)	30
5.4.8	Reset setting for inverse time tripping characteristics in the phase current path	30
5.4.9	Current setting for high set element ($I_{>>}$)	30
5.4.10	Trip delay for high set element ($t_{I_{>>}}$)	30
5.4.11	Pickup value for residual voltage U_E (ITER-relay type)	31
5.4.12	Pickup current for earth fault element ($I_{E>}$)	31
5.4.13	WARN/TRIP changeover	31
5.4.14	Time current characteristics for earth fault element (CHAR I_E) (not ER device type)	31
5.4.15	Trip delay or time multiplier for earth fault element ($t_{I_{E>}}$)	31
5.4.16	Resetting time for inverse time earth fault element (not ER-relay type)	31
5.4.17	Current setting for high set element of earth fault supervision ($I_{E>>}$)	31
5.4.18	Trip delay for high set element of earth fault supervision ($t_{I_{E>>}}$)	32
5.4.19	COS/SIN Measurement (ER - relay type)	32
5.4.20	Block/Trip – time (only ITE-device type)	32
5.4.21	Circuit breaker failure protection t_{CBFP}	32
5.4.22	Adjustment of the slave address	32

5.4.23	Setting of Baud-rate (applies for Modbus Protocol only)	32
5.4.24	Setting of parity (applies for Modbus Protocol only)	32
5.5	Fault recorder	33
5.5.1	Adjustment of the fault recorder.....	33
5.5.2	Number of the fault recordings	33
5.5.3	Adjustment of trigger occurrences	33
5.5.4	Pre-trigger time (T_{pre})	33
5.6	Adjustment of the clock.....	33
5.7	Additional functions.....	34
5.7.1	Blocking of the protective functions	34
5.8	Indication of measuring and fault values	37
5.8.1	Indication of measuring values	37
5.8.2	Unit of the measuring values displayed	37
5.8.3	Indication of fault data.....	38
5.8.4	Fault memory	38
5.9	Reset.....	39
5.9.1	Erasure of fault storage	39
5.9.2	Reset of the thermal replica register.....	39
6.	Relay testing and commissioning	40
6.1	Power-On.....	40
6.2	Testing the output relays and LEDs	40
6.3	Checking the set values.....	40
6.4	Secondary injection test.....	40
6.4.1	Test equipment	40
6.4.2	Example of test circuit for MRI3-ITE	41
6.4.3	Checking the input circuits and measured values	41
6.4.4	Example of a test circuit with earth fault directional feature	42
6.4.5	Checking the operating and resetting values of the relay	43
6.4.6	Checking the relay operating time	43
6.4.7	Checking the high set element of the relay	43
6.4.8	Checking the external blocking and reset functions	43
6.4.9	Testing the external blocking with Block/Trip function.....	44
6.4.10	Test of the CB failure protection	44
6.5	Primary injection test	44
6.6	Maintenance	45
7.	Technical data	46
7.1	Measuring circuits.....	46
7.2	Common data	46
7.3	Setting ranges and steps	47
7.3.1	Systemparameter	47
7.3.2	Overload protection	48
7.3.3	Over current time protection	49
7.3.4	Earth fault protection.....	50
7.3.5	Earth fault protection (ER-Type)	50
7.3.6	Determination of earth fault direction (MRI3-ITER)	51
7.3.7	BlockTrip – time**	51
7.3.8	Switch failure protection.....	51
7.3.9	Interface parameter	51
7.3.10	Parameter for the fault recorder.....	51
7.4	Tripping characteristics	52
7.4.1	Thermal characteristic	52
7.4.2	Preload factor.....	53
7.4.3	Inverse time over current protection relay	54
7.5	Tripping characteristics	55
7.6	Output relays	58
8.	Order form	59

1. Introduction and Application

The digital multifunctional relay MRI3-ITE(R) has been designed as a universal time over current protection relay with thermal replica for generators, transformers and cables.

The relay gives a complete thermal characteristic of the electrical equipment to be protected taking into account its initial load.

The MRI3-ITE(R) furthermore provides a universal time over current and earth fault protection with the following functions:

- Integrated determination of earth fault direction for application to power system networks with isolated or arc suppressing coil (Peterson coil) neutral earthing (ER-relay type),
- independent (Definite) time over current relay.
- inverse time over current relay with selectable characteristics,
- two-element (low and high set) earth fault protection with definite or inverse time characteristics.

2. Features and characteristics

- Microprocessor technology with self-supervision,
- measuring of phase current as RMS value,
- digital filtering of the measured values by using discrete Fourier analysis to suppress the high frequency harmonics and DC components induced by faults or system operations (earth current only),
- in accordance with the requirements as per IEC 255-8, VDE 435 part 3011 for overload relays,
- two parameter sets,
- selectable protective functions between:
 - definite time over current relay and
 - inverse time over current relay,
- selectable inverse time characteristics according to IEC 255-4:
 - Normal Inverse (Type A)
 - Very Inverse (Type B)
 - Extremely Inverse (Type C)
 - Special characteristics,
- Reset mode for inverse time characteristics selectable,
- high set over current element with instantaneous trip,
- two-element (inverse time and definite time) over current relay both for phase and earth faults,
- determination of earth short-circuit fault direction for systems with isolated or compensated neutral point,
- Display of measuring values as primary quantities,
- measuring of phase current of the short circuit breaker operation,
- blocking of high set element (e.g. for selective fault detection through minor over current protection units after unsuccessful AR),
- the protective functions can be freely assigned to the output relays (assignment matrix),
- withdrawable modules with automatic short circuiters of C.T. inputs when modules are with-drawn,
- storage of trip values and switching-off time (tCBFP) of 5 fault occurrences (fail-safe of voltage),
- recording of up to eight fault occurrences with time stamp,
- switch failure protection,
- serial data exchange via RS485 interface possible; alternatively with RS485 Pro-Open Data Protocol or Modbus Protocol,
- Display of date and time.

Important:

For additional common data of all MR-relays please refer to manual „MR-Digital Multifunctional relays“.

3. Design

3.1 Connections

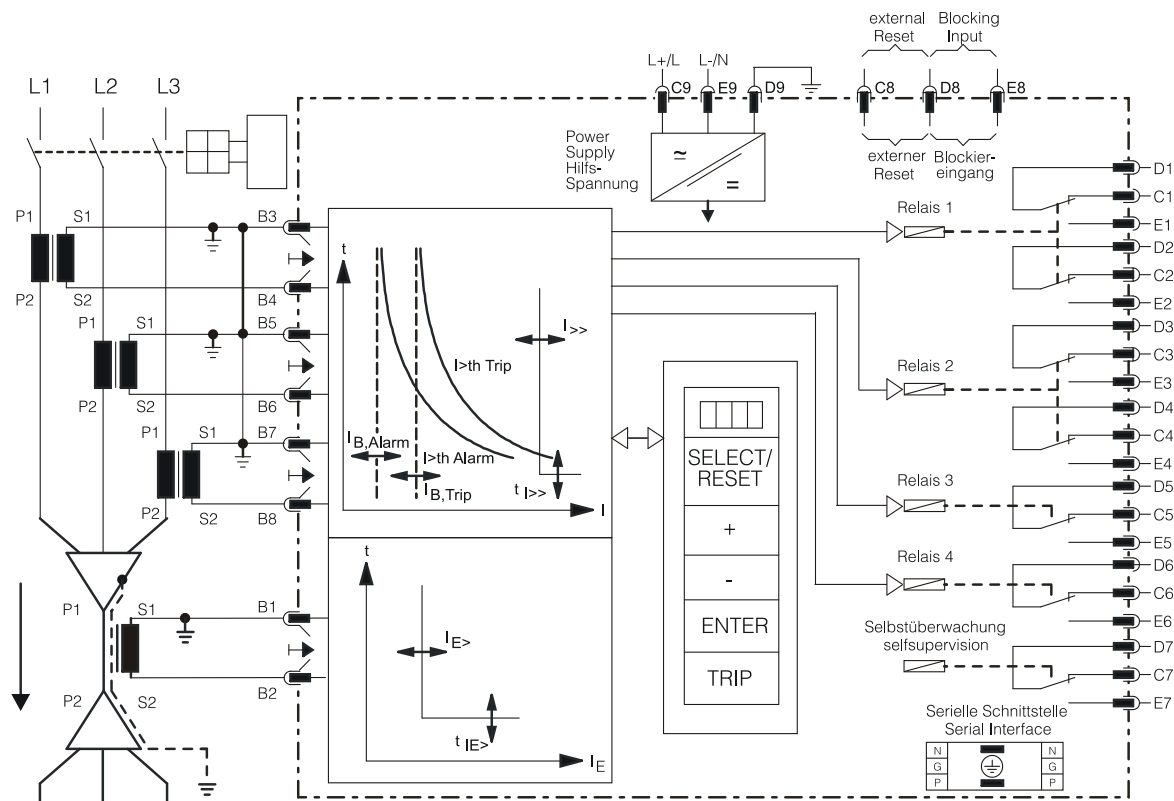

Figure 3.1: Connection diagram

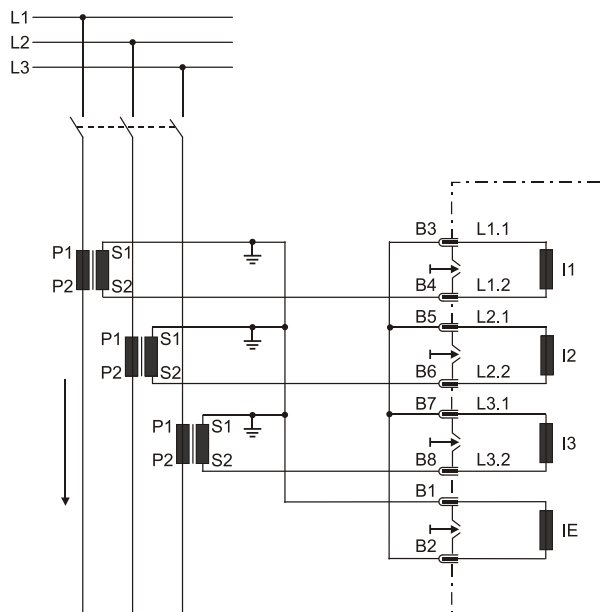

Figure 3.2: Phase current measuring and earth-current detection by means of Holmgreen-circuit.

This connection can be used with three existing phase current transformers when combined phase and earth-current measuring is required.

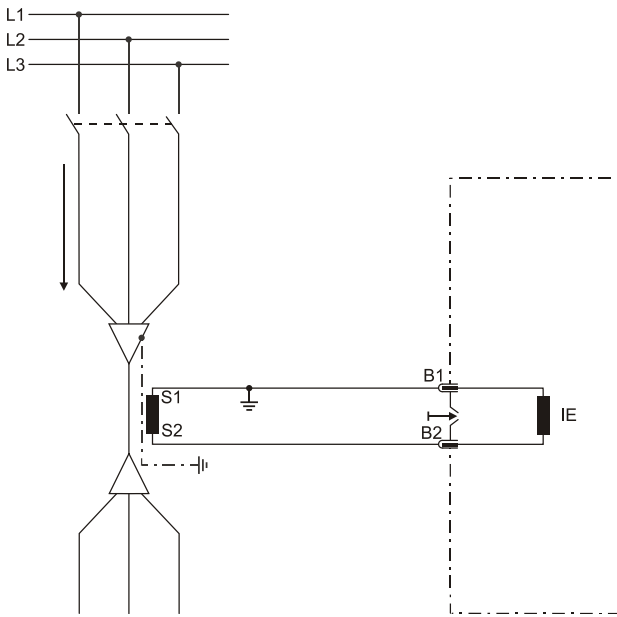

Figure 3.3: Earth-fault measuring by means of ring-core C.T. (IE)

When phase- and earth-fault current measuring are combined, the connection has to be realized as per Figure 3.2 and Figure 3.3.

Voltage measuring for the directional detection:

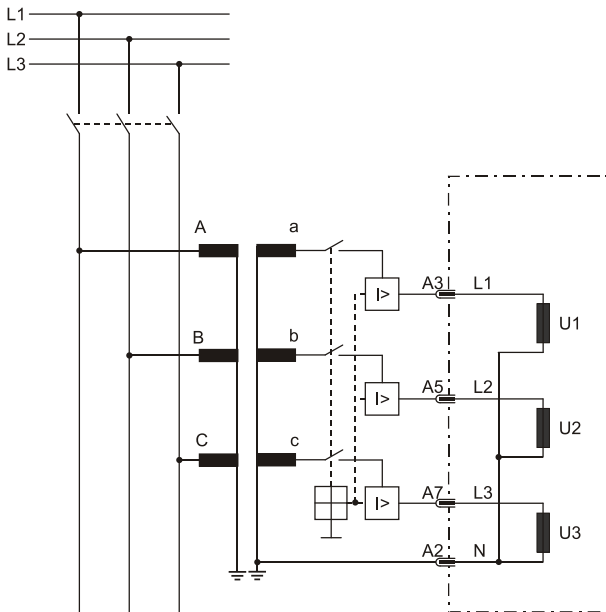

Figure 3.4: Measuring of the phase voltages for the directional detection at earth-fault protection ($I_E >$ and $I_E <$).

3.1.1 Analogue input circuits

The protection unit receives the analogue input signals of the phase currents I_{L1} (B3-B4), I_{L2} (B5-B6), I_{L3} (B7-B8) and the residual current I_E (B1-B2) each via separate input transformers. The constantly detected current measuring values are galvanically decoupled, filtered and finally fed to the analogue/digital converter.

3.1.2 Output relays

Two relays are equipped with two change-over contacts and three relays with each one change-over contact for alarm. Apart from the relay for self-supervision, all protective functions can be optionally assigned:

- Relay 1: C1, D1, E1 and C2, D2, E2
- Relay 2: C3, D3, E3 and C4, D4, E4
- Relay 3: C5, D5, E5
- Relay 4: C6, D6, E6
- Relay 5: Self-supervision C7, D7, E7

All trip and alarm relays are working current relays, the relay for self supervision is an idle current relay.

3.2 Relay output contacts

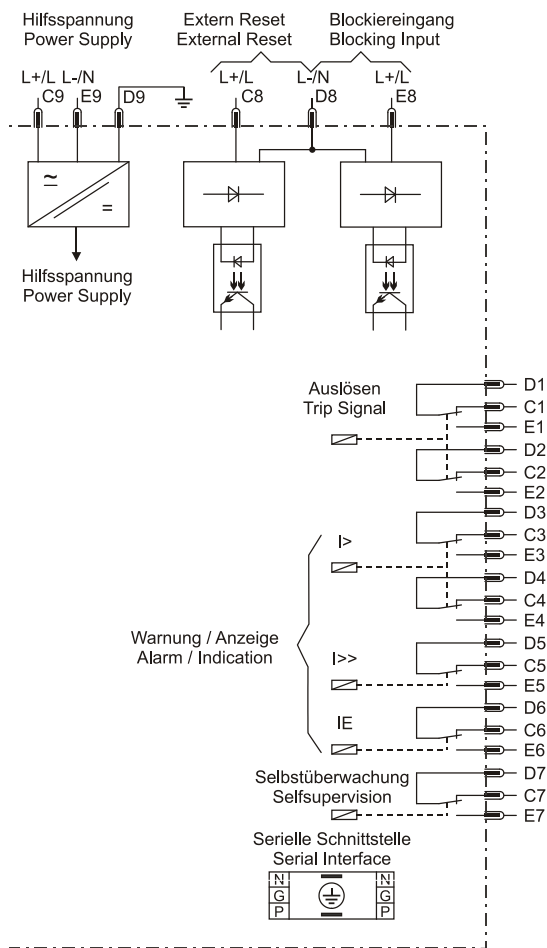

Figure 3.5: Relay outputs

3.2.1 Blocking input

The function for blocking can be parameterized arbitrary. When an auxiliary voltage is connected to D8/E8 those relay functions will be blocked which were parameterized before (see chapter 5.7.1).

3.2.2 External reset input

See chapter 5.9

3.2.3 Fault recorder

The MRI3-ITER has a fault value recorder which records the measured analogue values as instantaneous values. The instantaneous values

$$i_{L1}, i_{L2}, i_{L3}, i_E,$$

are scanned at a raster of 1.25 ms (at 50 Hz) and 1.041 ms (at 60 Hz) and saved in a cyclic buffer. It is possible to store 1 - 8 fault occurrences with a total recording time of 16 s (with 50 Hz) and 13.33 s (with 60 Hz) per channel.

Storage division

Independent of the recording time, the entire storage capacity can be divided into several cases of disturbance with a shorter recording time each. In addition, the deletion behavior of the fault recorder can be influenced.

No writing over

If 2, 4 or 8 recordings are chosen, the complete memory is divided into the relevant number of partial segments. If this max. number of fault event has been exceeded, the fault recorder block any further recordings in order to prevent that the stored data are written over. After the data have been read and deleted, the recorder to ready again for further action.

Writing over

If 1, 3 or 7 recordings are chosen, the relevant number of partial segments is reserved in the complete memory. If the memory is full, a new recording will always write over the oldest one.

The memory part of the fault recorder is designed as circulating storage. In this example 7 fault records can be stored (written over).

Memory space 6 to 4 is occupied.

Memory space 5 is currently being written in

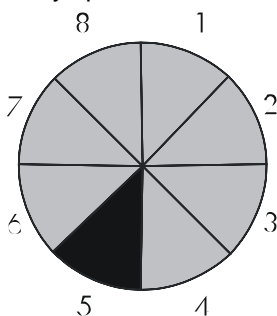

Figure 3.6: Division of the memory into 8 segments, for example

Since memory spaces 6, 7 and 8 are occupied, this example shows that the memory has been assigned more than eight recordings. This means that No. 6 is the oldest fault recording and No. 4 the most recent one.

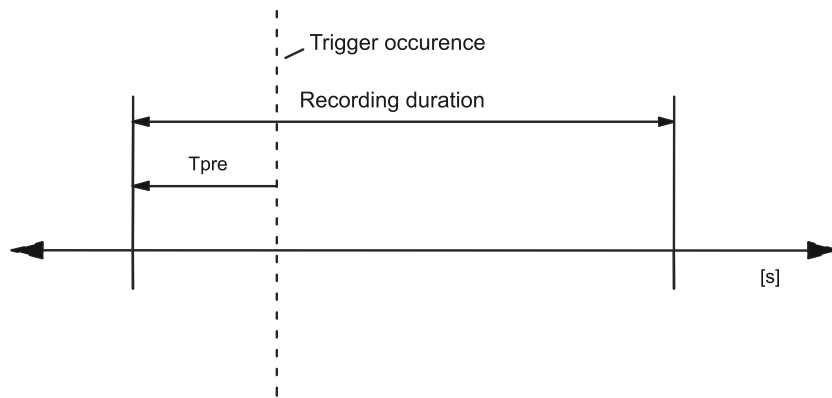

Figure 3.7: Basic set-up of the fault recorder

Each memory segment has a specified storage time which permits setting of a time prior to the trigger event.

Via the interface RS485 the data can be read and processed by means of a PC with HTL/PL-Soft4. The data is graphically edited and displayed. Bi-nary tracks are recorded as well, e.g. activation and trip.

3.3 Front plate

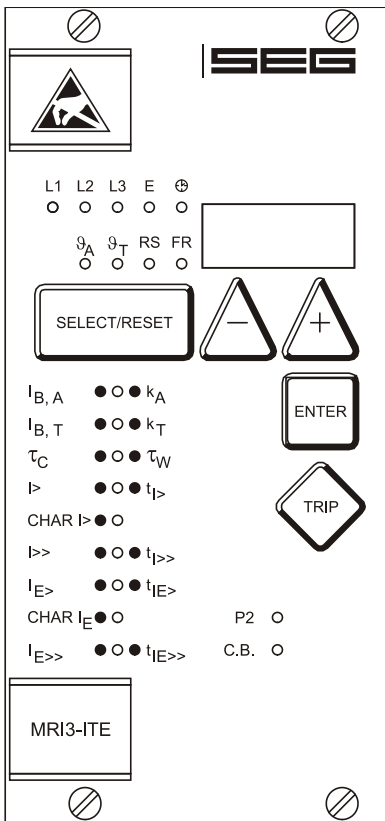

Figure 3.8: Front plate MRI3-ITE

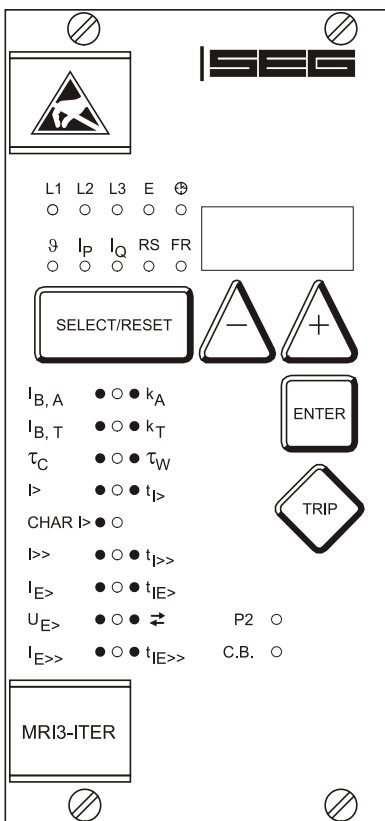

Figure 3.9: Front plate MRI3-ITER

The LED RS, 9_A and 9_T yellow light up yellow (MRI3-ITE)

The LED RS, IP and IQ light up yellow (MRI3-ITER).

All other LEDs are two-colored. LEDs left to the alphanumerical display light-up green during measuring and red at alarm.

LEDs underneath the pushbutton <SELECT/RESET> light-up green during setting and inquiry of the setting values printed left to the LEDs. They light-up red when the setting values printed at the right to the LEDs are activated.

The LED labeled with the letters LR is a light while the fault recorder is being adjusted.

4. Working principle

4.1 Analog circuits

The incoming currents from the main current transformers on the protected object are converted to voltage signals in proportion to the currents via the input transformers and burden. The noise signals caused by inductive and capacitive coupling are suppressed by an analogue RC filter circuit. The analogue voltage signals are fed to the A/D-converter of the microprocessor and transformed to digital signals through Sample and Hold circuits. The analogue signals are sampled at 50 Hz (60 Hz) with a sampling frequency of 800 Hz (960 Hz), namely, a sampling rate of 1.25 ms (1.04 ms) for every measuring quantity.

4.2 Digital circuits

The essential part of the MRI3-ITE relay is a powerful microcontroller. All of the operations, from the analogue digital conversion to the relay trip decision, are carried out by the microcontroller digitally. The relay program is located in an EPROM (Electrically-Programmable-Read-Only-Memory). With this program the CPU of the microcontroller calculates the three phase in order to detect a possible fault situation in the protected object.

For the calculation of the current value an efficient digital filter based on the Fourier Transformation (DFFT - Discrete Fast Fourier Transformation) is applied to suppress high frequency harmonics and DC components caused by fault-induced transients or other system disturbances. The calculated actual current values are compared with the relay settings.

In case, the time for which a current was above the preset pickup value, exceeds the trip delay or the thermal capacity is reached, an alarm signal will be given. Dependent on their adjustment the output relays will also be activated.

The relay setting values for all parameters are stored in a parameter memory (EEPROM – Electrically Erasable Programmable Read-only Memory), so that the actual relay settings cannot be lost, even if the power supply is interrupted. The micro-processor is supervised by a built-in "watchdog" timer. In case of a failure the watchdog timer re-sets the microprocessor and gives an alarm signal, via the output relay "self supervision".

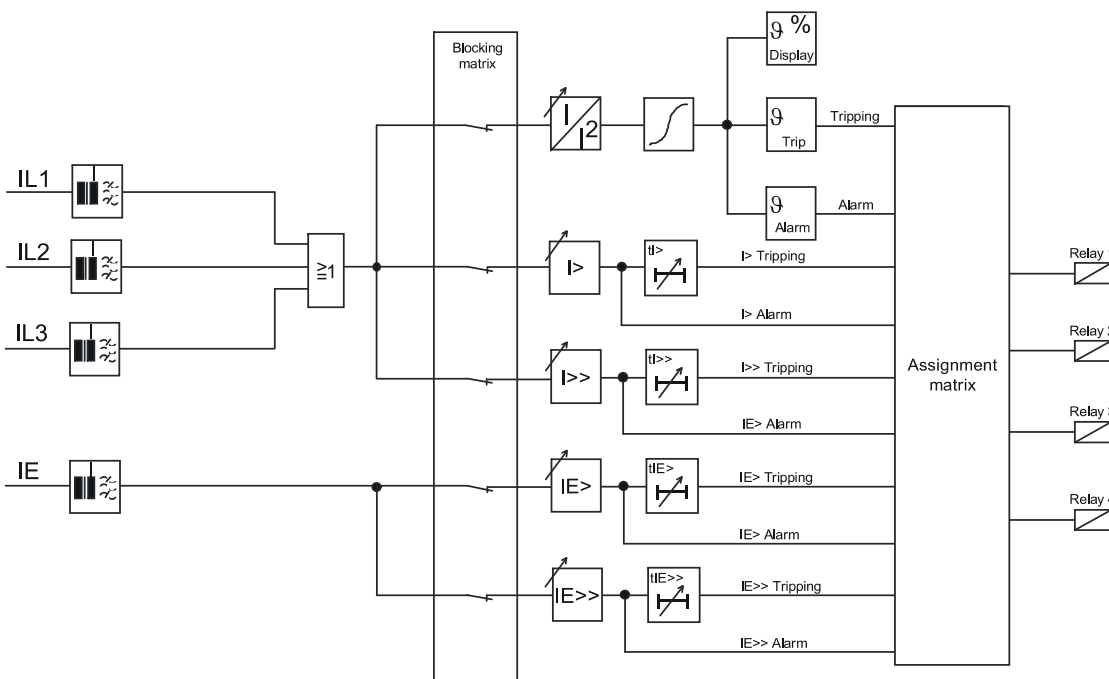

Figure 4.1: Block diagram

4.3 Thermal replica

4.3.1 Definitions

Basic current I_B :

Set limiting value of the overload current at which the relay must not trip. This, in general, is the maximally permissible operating current in consideration of additional influencing quantities on the heating (e.g. heat dissipation by transformer oil or air convection).

The settings of the overload characteristics refer to this basic current.

Time constant k :

Constant to be multiplied by the basic current in order to determine the current that may be higher than I_B .

Instruction for motor protection: $k = 1 \dots 1.2$

MRI3-ITE(R) default value: $k = 0.5$

Remark:

For the calculation of the temperature equivalent, only the basic current has to be taken into account: $I_{B2} \sim \vartheta$.

The constant k is used to determine the pickup value

$(I_B \cdot k)$ and to calculate the temperature according to which the object to be protected reaches its tripping value after expiry of a long time ($\square \text{Trip} = k^2 \cdot 100\%$).

- Adjustment of the nominal current with I_B (e.g. $1 \cdot I_N$) and selection of an overload factor k (e.g. 1.2). From this, a pickup value of $1.2 \cdot I_N$ and a tripping value of 144% will result.

Thermal time constant τ :

It indicates the time until the temperature of the electrical equipment to be protected reaches 63% of the stationary operating temperature. (data sheet of the electrical equipment or practical values). Thumb rule: With the current I being constant, approx. 63% of the maximal temperature will be reached when $t = \tau$. After expiry of a time $t = 5 \cdot \tau$ the maximal temperature is almost reached (99%).

The time constant for warming up and that for cooling down may be different!

Tripping characteristic with preload:

Characteristic with complete memory function, taking into account the thermal effect of the current before occurrence of the overload in the thermal replica of the electrical item to be protected.

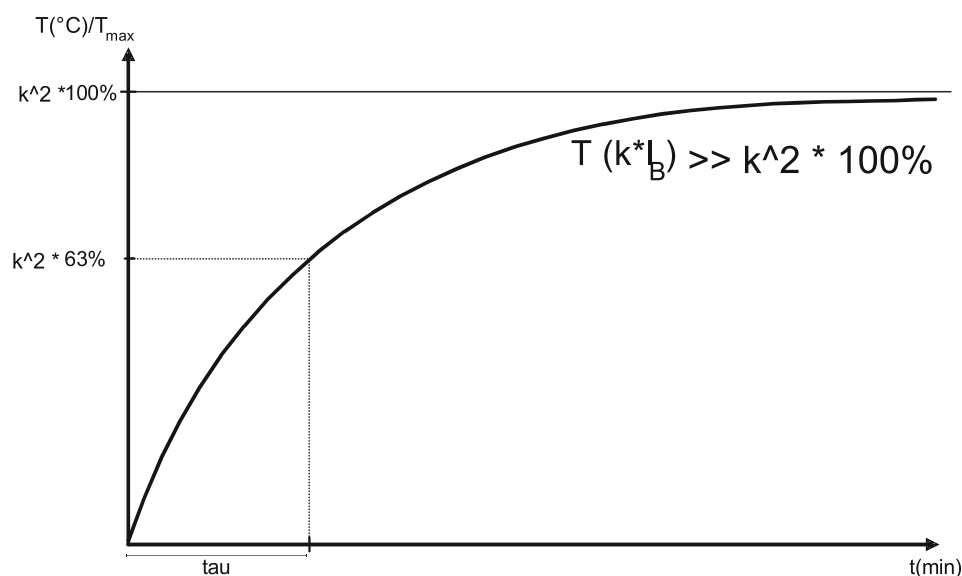

Figure 4.2: Thermal time constant τ

4.4 Algorithm

Based on the defined thermal model, one can de-duce that an energy Q is stored in the electrical equipment.

After expiry of a long time and with a constant cur-rent load, a stationary condition will be achieved in which the temperature of the electrical equipment does not increase anymore. The heat supplied for a unit of time is equal to that released by cooling down (steady energy balance).

$$Q_{\text{released}} = Q_{\text{supplied}}$$

The supplied thermal energy as well as the temperature ϑ of the electrical equipment in stationary condition are in proportion to the square of the phase current (e.g. ohmic losses and iron losses in the transformer).

$$Q \sim I^2 \quad \text{or} \quad \vartheta \sim I^2$$

Since the pickup value in the MRI3-ITE is deter-mined by I_B , the following relation is effective:

$$\vartheta_n \cdot k^2 \sim (I_B \cdot k)^2$$

For this purpose, the temperature T that really prevails in the electrical equipment needs to be known. This temperature ϑ (in%) is described in the thermal replica through the temperature equiv-alent $k \cdot I_B$. When being loaded with the maximum permissible operating current B in stationary condition, the electrical equipment reaches the maximum allowed operating temperature ϑ_B . For this load, the temperature equivalent is defined as $k^2 \cdot 100\%$.

$$\vartheta \cdot (\%) = \frac{I^2}{(k \cdot I_B)^2} \cdot 100\%$$

I.e.: At a load with $I = 0.9 \times (k \cdot I_B)$ and $k \cdot I_B = 1.2$, and according to the before indicated definition, the temperature reaches 81% of the maximum permissible operating temperature. For an electrical equipment that - after initial load - will be loaded beyond the admissible operating current ($I > k \cdot I_B$), the following temperature curve will result:

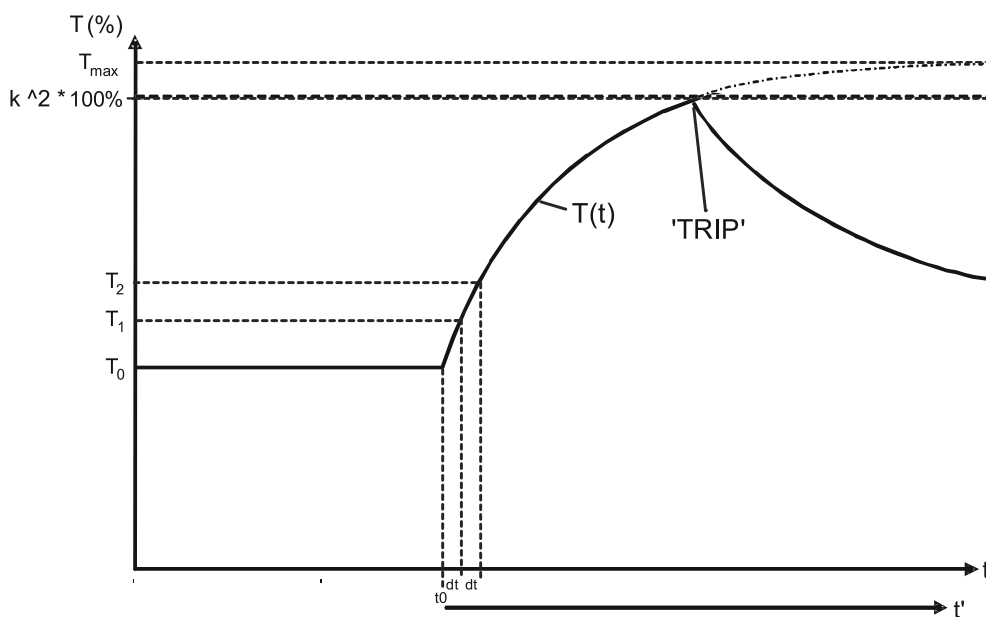

Figure 4.3: Warming up of an electrical item

The thermal equivalent ($T = \vartheta$) is described by an exponential function.

for ($\vartheta > \vartheta_0$):

$$\vartheta \cdot (t') = \vartheta_0 + (\vartheta_{\max} - \vartheta_0) \cdot (1 - e^{-\frac{t'}{\tau}})$$

after transposition:

$$\vartheta \cdot (t) = \vartheta_{\max} + (\vartheta_0 - \vartheta_{\max}) \cdot e^{-\frac{t'}{\tau}}$$

If (t') $\geq k^2 \cdot 100\%$ the alarm or trip element is activated.

The temperature after dt can be calculated as follows:

$$\vartheta_1 = \vartheta_{\max} + (\vartheta_0 - \vartheta_{\max}) \cdot e^{-\frac{dt}{\tau}}$$

After 2 times dt :

$$\vartheta_2 = \vartheta_{\max} + (\vartheta_0 - \vartheta_{\max}) \cdot e^{-\frac{2dt}{\tau}}$$

or

$$\vartheta_2 = \vartheta_{\max} + (\vartheta_1 - \vartheta_{\max}) \cdot e^{-\frac{dt}{\tau}}$$

general:

$$\vartheta_n = \vartheta_{\max} + (\vartheta_{n-1} - \vartheta_{\max}) \cdot e^{-\frac{dt}{\tau}}$$

Thus, a recursion formula was established from which in order to calculate the thermal equivalent ϑ_n :

- The last value ϑ_{n-1} ,
- the stationary final value ϑ_{\max} for the actual current,
- the adjusted time constant τ ,
- and the time since the last calculation dt must be known.

Analogous, for the temperature equivalent ϑ with ϑ_{\max} the following formula is applied:

$$\vartheta(t') = \frac{I^2}{(k \cdot I_B)^2} \cdot 100\% + \left(\vartheta_0 - \frac{I^2}{(k \cdot I_B)^2} \cdot 100\% \right) \cdot e^{-\frac{t'}{\tau}}$$

with I = highest measured phase current.

In each new calculation step n , the momentary temperature equivalent is determined as follows:

$$\vartheta_n = \frac{I_n^2}{(k \cdot I_B)^2} \cdot 100\% + \left(\vartheta_{n-1} - \frac{I_n^2}{(k \cdot I_B)^2} \cdot 100\% \right) \cdot e^{-\frac{dt}{\tau}}$$

- with
- I_n : Highest measured phase current in calculation step n
 - dt : Time interval between the individual calculation steps
 - ϑ_{n-1} : Temperature equivalent of the preceding calculation step

The temperature equivalent ϑ_{n-1} has not been calculated after start of the protection program (connection of auxiliary voltage), therefore, the temperature state of the electrical item to be protected is expected to be cold.

If, however, the electrical equipment has been initially loaded, it will take approximately $3 \times \tau_{\text{warming up}}$, (at constant load) until the thermal equivalent equals the real state.

Different time constants:

After switching off the electrical equipment ($I_n = 0$) temperature will decrease and tend towards $\vartheta_n = 0$ (environmental temperature).

e.g.: $\vartheta_{\text{cooling down}} = 2 \tau_{\text{warming up}}$

Depending on the comparison between the last measured current and the actual current the cooling down or warming up constant will be applied for calculation.

$I_n \geq I_{n-1} \Rightarrow$ warming up

$I_n < I_{n-1} \Rightarrow$ cooling down

If the relay is supplied by the mains to be protected, i.e. if the relay is not supplied to auxiliary voltage after tripping of the mains c.b., the following has to be considered:

After return of the supply voltage, it is assumed that the electric item is in cold condition. In this case this assumption does not comply with the reality. Therefore an external supply voltage should be applied.

The tripping criterion for the alarm or tripping element of the thermal characteristic is:

$$\vartheta_{\text{Trip}} > k^2 \cdot 100\%$$

The effective values of the measured phase currents are detected by calculating the root out of the integral of a period's momentary current squares. Calculation of the thermal equivalent is always based on the highest of the three phase currents.

4.5 Earth fault protection

4.5.1 Generator stator earth fault protection

With the generator neutral point earthed as shown in Figure 4.4 the MRI3-ITER picks up only to phase earth faults between the generator and the location of the current transformers supplying the relay.

Earth faults beyond the current transformers, i.e. on the consumer or line side, will not be detected.

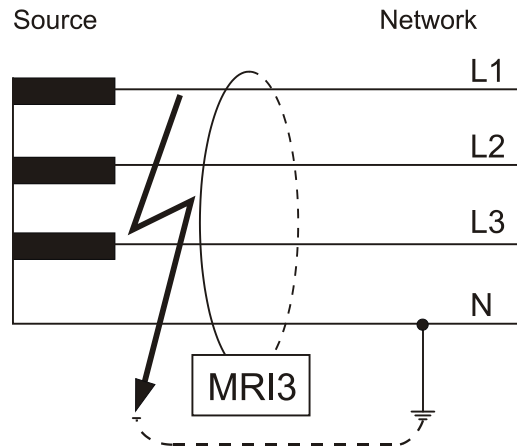

Figure 4.4: Generator stator earth fault protection

4.5.2 System earth fault protection

With the generator neutral point earthed as shown in Figure 4.5, the MRI3-ITER picks up only to earth faults in the power system connected to the generator. It does not pick up to earth faults on the generator terminals or in generator stator.

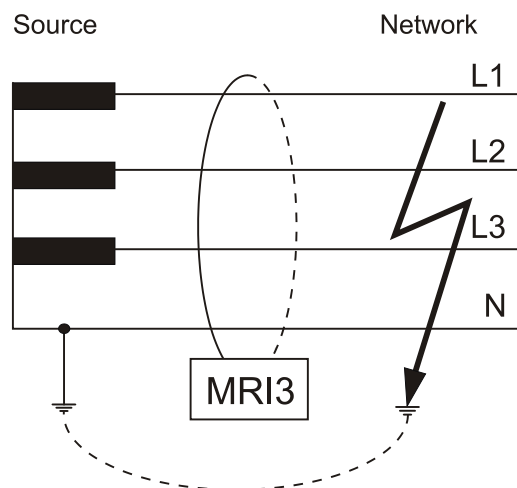

Figure 4.5: System earth fault protection

4.6 Earth-fault directional feature (ER-relay type)

A built-in earth-fault directional element is available for applications to power networks with isolated or with arc suppressing coil compensated neutral point.

For earth-fault direction detection it is mainly the question to evaluate the power flow direction in zero sequence system. Both the residual voltage and neutral (residual) current on the protected line are evaluated to ensure a correct direction decision.

In isolated or compensated systems, measurement of reactive or active power is decisive for earth-fault detection. It is therefore necessary to set the relay to measure according to $\sin \varphi$ or $\cos \varphi$ methods, depending on the neutral-point connection method.

The residual voltage U_E required for determining earth fault direction can be measured in three different ways, depending on the voltage transformer connections.

(refer to Table 4.1) Total current can be measured by connecting the unit either to a ring core C.T. or to current transformers in a Holmgreen circuit. However, maximum sensitivity is achieved if the MRI3-ITER protective device is connected to a ring core C. T. (see Figure 3.3).

The pick-up values $I_{E>}$ and $I_{E>>}$ (active or reactive current component for $\cos \varphi$ or $\sin \varphi$ method) for ER-relay types can be adjusted from 0.01 to $0.45 \times I_N$.

Adjustment possibility	Application	Voltage transformer connections	Measured voltage at earth fault	Correction factor for residual voltage
„3pha“	3-phase voltage transformer connected to terminals A3, A5, A7, A2		$\sqrt{3} \times U_N = 3 \times U_{1N}$	$K = 1 / 3$
„e-n“	e-n winding connected to terminals A3, A2		$U_N = \sqrt{3} \times U_{1N}$	$K = 1 / \sqrt{3}$
„1:1“	Neutral-point voltage (= residual voltage) terminals A3, A2		$U_{1N} = U_{NE}$	$K = 1$

Table 4.1: Connection of voltage transformers

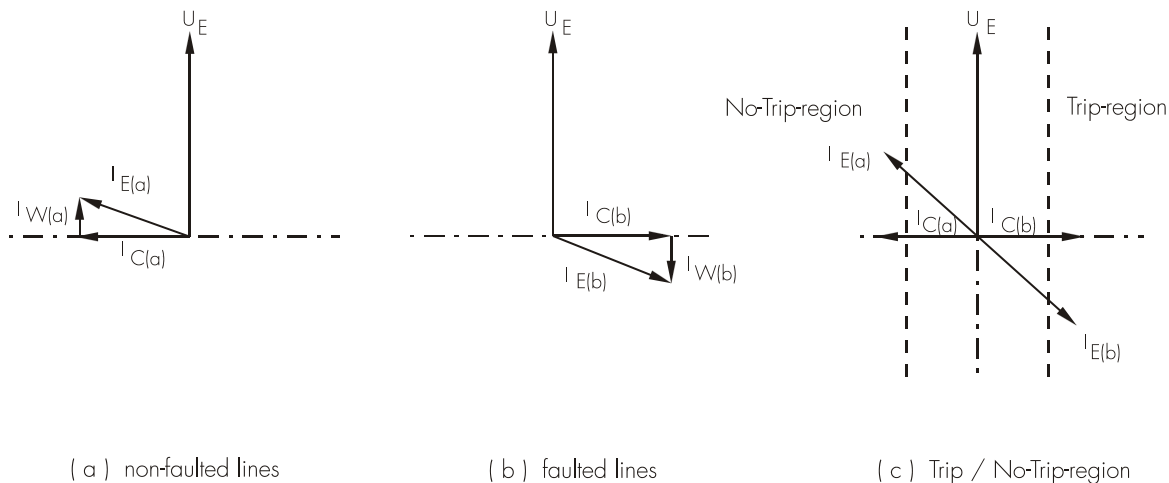

Figure 4.6: Phase position between the residual voltage and zero sequence current for faulted and non-faulted lines in case of isolated systems ($\sin \varphi$)

- U_E - residual voltage
- I_E - zero sequence current
- I_C - capacitive component of zero sequence current
- I_W - resistive component of zero sequence current

By calculating the reactive current component ($\sin \varphi$ adjustment) and then comparing the phase angle in relation to the residual voltage U_E , the ER/XR-relay type determines whether the line to be protected is earth-faulted.

On non-earth-faulted lines, the capacitive component $I_C(a)$ of the total current precedes the residual voltage by an angle of 90° . In case of a faulty line the capacity current $I_C(b)$ lags behind the residual voltage at 90° .

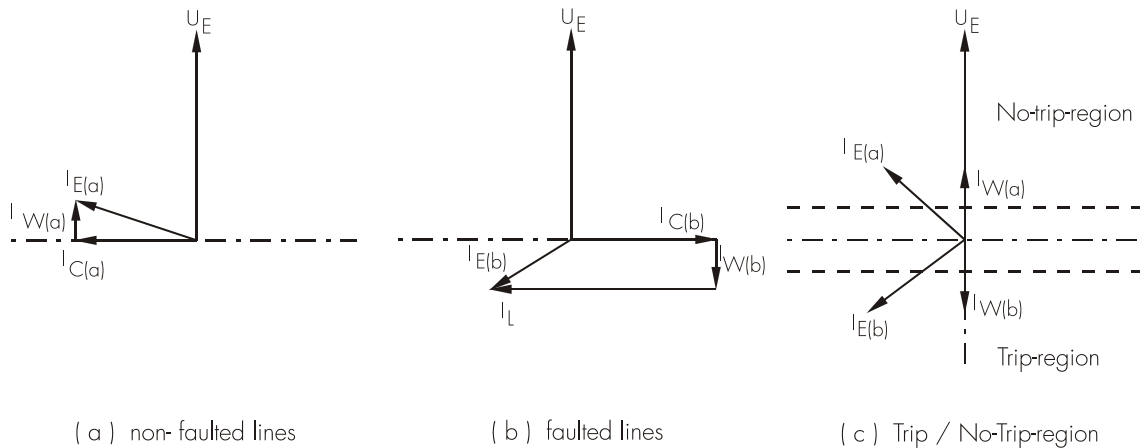

Figure 4.7: Phase position between the residual voltage and zero sequence current for faulted and non-faulted lines in case of compensated systems ($\cos \varphi$)

- U_E - residual voltage
- I_E - zero sequence current
- I_L - inductive component of zero sequence current (caused by Petersen coil)
- I_C - capacitive component of zero sequence current
- I_W - resistive component of zero sequence current

In compensated mains the earthfault direction cannot be determined from the reactive current components because the reactive part of the earth current depends upon the compensation level of the mains. The ohmic component of the total current (calculated by $\cos \varphi$ adjustment) is used in order to determine the direction.

The resistive component in the non-faulted line is in phase with the residual voltage, while the resistive component in the faulted line is opposite in phase with the residual voltage.

By means of an efficient digital filter harmonics and fault transients in the fault current are suppressed. Thus, the uneven harmonics which, for instance, are caused an electric arc fault, do not impair the protective function.

4.7 Demand imposed on the main current transformers

The current transformers have to be rated in such a way, that a saturation should not occur within the following operating current ranges:

Independent time over current

function:

$$K1 = 2$$

Inverse time over current function:

$$K1 = 20$$

High-set function:

$$K1 = 1.2 - 1.5$$

K1 = Current factor related to set value

Moreover, the current transformers have to be rated according to the maximum expected short circuit current in the network or in the protected objects.

The low power consumption in the current circuit of MRI3-ITER, namely $<0,2 \text{ VA}$, has a positive effect on the selection of current transformers. It implies that, if an electromechanical relay is replaced by MRI3-ITER, a high accuracy limit factor is automatically obtained by using the same current transformer.

5. Operation and settings

5.1 Display

Function	Display shows	Pressed pushbutton	Corresponding LED
Normal operation	WW		
Measured operating values	actual measured values, related to I_N , Temperature equivalent in %	<SELECT/RESET> one time for each value	L1, L2, L3, E $\vartheta_A, \vartheta_T, I_P, I_Q$
Measuring range overflow	max.	<SELECT/RESET>	ϑ_A und ϑ_T
Display of the second rated repetition current	SEC 0.002-50.0 kA=prim	<+> <-><SELECT/RESET>	L1, L2, L3, E
Rated frequency	f = 50 / f = 60	<+> <-><SELECT/RESET>	
LED-blinking after activation	FLSH/NOFL	<+> <-><SELECT/RESET>	
Parameter switch/external triggering of the fault recorder	SET1, SET2, B_S2, R_S2, B_FR, R_FR, S2_FR	<+> <-><SELECT/RESET>	P2
Constant k	Factor for pickup current	<+> <-><SELECT/RESET>	k_A and k_T
Time constant τ	Cooling time/warming up time constant	<+> <-><SELECT/RESET>	τ_C and τ_W
Blocking of function	EXIT	<+> until max. setting value	LED of blocked parameter
Characteristics	DEFT, NINV, VINV, EINV, LINV, RINV,	<+> <-><SELECT/RESET>	CHAR I>
Characteristics	DEFT, NINV, VINV, EINV, LINV, RINV	<+> <-><SELECT/RESET>	CHAR IE>
Switch failure protection	CBFP	after tripping	C. B.
Recorded fault data	Phase currents, earth currents and temperature equivalent	<SELECT/RESET> one time for each phase	L1, L2, L3, E ϑ_A and ϑ_T
Enquiry failure memory	FLT1, FLT2.....	<+> <-><SELECT/RESET>	L1, L2, L3, E I>, I>>, IE>, IE>>,
Delete failure memory	wait	<+> <-><SELECT/RESET>	
Relay trip	TRIP	<TRIP> or after fault tripping	
Secret password input	„XXXX“	<+><-> <ENTER> <SELECT/RESET>	
System reset	WW	<SELECT/RESET> for about 3 s	
Manual trip	TRI?	<TRIP> three times	
Inquire password	PSW?	<TRIP><ENTER>	
Blocking of protection function	BLOC, NO_B	<ENTER> und <TRIP>	
Change over the blockage function ²⁾	PR_B, TR_B	<ENTER> und <TRIP>; <+><->	I>, I>>, IE>, IE>>, oder tI>, tI>>, tIE>, tIE>>
Relay assignment	e. g. _ 2 _	<ENTER> and <TRIP>	
Trigger signal for the fault recorder	P_UP; A_PI; TRIP; TEST	<+> <-><SELECT/RESET>	FR
Number of fault occurrences	S = 2, S = 4, S = 8	<+> <-><SELECT/RESET>	FR
Display of date and time	Y = 99, M = 10, D = 1, h = 12, m = 2, s = 12	<+> <-><SELECT/RESET>	□
Slave address of serial interface	1-32	<+> <-><SELECT/RESET>	RS
Baud-Rate ¹⁾	1200-9600	<SELECT/RESET> <+><->	RS
Parity-Check ¹⁾	even odd no	<SELECT/RESET> <+><->	RS
Parameter switch	SET1; SET2	<+> <-><SELECT/RESET>	P2
Setting values: Currents and time delays	Current and time settings	<SELECT/RESET> one time for each parameter	I _{B,A} ; I _{B,T} ; k _A ; k _T ; I>; CHAR I>; t _I >; I>>; t _I >>; I _E >; CHAR I _E >; t _{I_E} >; I _E >>;

Function	Display shows	Pressed pushbutton	Corresponding LED
			t _{E>>}
Save parameter?	SAV?	<ENTER>	
Save parameter!	SAV!	<ENTER> for about 3 s	
Display of software-version	First part (e.g. D21-) Second part (e.g. 1.00)	<TRIP> one time for each part	
Setting of the transformer connections of U _{E>}	1:1; e-n; 3pha	<+> <-><SELECT/RESET>	U _{E>}

Table 5.1: Possible indication messages on the display

1) only Modbus

2) only ITE

5.1.1 LEDs

LED-Name	Mode	Colour	LED-Display	Meaning
L1, L2, L3, E	Display of measuring values	green	continuously	Current measuring (phase or earth current)
ϑ_A and ϑ_T ϑ	Display of measuring values	yellow (MRI3-ITE) red/green (MRI3-ITER)	continuously	Measuring of the temperature equivalent (%)
ϑ_T ϑ	Calculated value	yellow (MRI3-ITE) red (MRI3-ITER)		Time until release, after $I_{B,T} > k_T$ has been exceeded
L1, L2, L3, E	Pickup	red	flashing	Over current pickup (phase or earth current)
IP, IQ*	Display of measuring values	yellow	continuously	active and reactive current component for earth current
ϑ_A and ϑ_T	Pickup	yellow	flashing	Base current exceeded ($I_{B,*}k$)
ϑ_A and ϑ_T^*	Pickup	green	flashing	Base current exceeded ($I_{B,*}k$)
ϑ_A and ϑ_T^*	Pickup	red	flashing	Base current exceeded ($I_{B,*}k$)
L1, L2, L3, E, ($I_>$, $I_{>>}$, $I_{E>}$, $I_{E>>}$)	After pickup	red	flashing (short)	Pickup signaled (In combination with trip element only)
L1, L2, L3, E	Tripping	red	continuously	Over current tripping (phase or earth current)
L1, L2, L3, E, ϑ_A and ϑ_T ($I_{B,A}$, $I_{B,T}$)	After pickup	yellow	flashing (short)	Pickup signaled (In combination with trip element only)
ϑ_A	Warning at $k^2 \square$ 100%	yellow/MRI3-ITE green/MRI3-ITER	continuously	Temperature limit of overload low set element reached
ϑ_T	Tripping at $k^2 \cdot$ 100%	yellow / MRI3-ITE red / MRI3-ITER	continuously	Temperature limit of trip element reached
ϑ_A^*	Warning at $k^2 \cdot$ 100%	green	continuously	Temperature limit of overload low set element reached
ϑ_T^*	Tripping at $k^2 \cdot$ 100%	red	continuously	Temperature limit of trip element reached
$I_{B,A}$	Setting	green	continuously	Setting switch point
k_A	Setting	red	continuously	Define constant
$I_{B,A}$	Setting	green	continuously	Time until activation of alarm
$I_{B,A}$ (ϑ_A)	Pickup	green	flashing	Base current exceeded ($I_{B,A}k$)
$I_{B,A}$ (ϑ_A)	Tripping	red	flashing	Temperature limit of overload low set element reached
$I_{B,T}$	Setting	green	continuously	Setting switching point
k_T	Setting	red	continuously	Define constant
$I_{B,T}$	Setting	green	continuously	Time until activation of alarm
$I_{B,A}$ (ϑ_T)	Pickup	red	flashing	Base current exceeded ($I_{B,T}k$)
$I_{B,T}$ (ϑ_T)	Tripping	red	continuously	Temperature limit of trip element reached
τ_C	Setting	green	continuously	Cooling time constant
τ_W	Setting	red	continuously	Warming up constant
$I_>$	Setting	green	continuously	Setting switching point $I_>$
CHAR $I_>$	Setting	green	continuously	Select characteristic
$t_{I_>}$	Setting	red	continuously	Setting time delay $t_{I_>}$
$t_{I_>}$, CHAR $I_>$	Setting	red/green	continuously	Reset mode activating
$I_>$, $t_{I_>}$	Pickup	red	flashing	Pickup of $I_>$
$I_>$, $t_{I_>}$	Tripping	red	continuously	$I_>$ tripped
$I_{>>}$	Setting	green	continuously	Setting switching point $I_{>>}$
$t_{I_{>>}}$	Setting	red	continuously	Setting time delay $t_{I_{>>}}$
$I_{>>}$, $t_{I_{>>}}$	Pickup	red	flashing	Pickup of $I_{>>}$
$I_{>>}$, $t_{I_{>>}}$	Tripping	red	continuously	$I_{>>}$ tripped
$I_{E>}$	Setting	green	continuously	Setting switching point $I_{E>}$
CHAR $I_{E>}^{**}$	Setting	green	continuously	Select characteristic
$t_{I_{E>}}$	Setting	red	continuously	Setting time delay $t_{I_{E>}}$
$t_{I_{E>}}$, CHAR $I_{E>}^{**}$	Setting	red/green	continuously	Reset mode activating
$\rightarrow\leftarrow^*$	Setting/tripping	red	continuously	Directional feature for earth current

LED-Name	Mode	Colour	LED-Display	Meaning
$I_{E>}$, $t_{IE>}$	Pickup	red	flashing	Pickup of $I_{E>}$
$I_{E>}$, $t_{IE>}$	Tripping	red	continuously	$I_{E>}$ tripped
$I_{E>>}$	Setting	green	continuously	Setting switching point $I_{E>>}$
$t_{IE>>}$	Setting	red	continuously	Setting time delay $t_{IE>>}$
$I_{E>>}$, $t_{IE>>}$	Pickup	red	flashing	Pickup of $I_{E>>}$
$I_{E>>}$, $t_{IE>>}$	Tripping	red	continuously	$I_{E>>}$, tripped
RS	Setting	yellow	continuously	Setting slave address

Table 5.2: LED-indication

* MRI3-ITER type only

**only MRI3-ITE type

5.2 Setting procedure

After push button <SELECT/RESET> has been pressed, always the next measuring value is indicated. Firstly the operating measuring values are indicated and then the setting parameters. By pressing the <ENTER> push button the setting values can directly be called up and changed. Before parameter setting can be started the relevant password must be entered (refer to Chapter 4.4 of the "MR Digital Multifunctional Relay" Description).

5.3 System parameter

5.3.1 Display of measuring values as primary quantities (I_{prim} phase)

With this parameter it is possible to show the indication as primary measuring value. For this purpose the parameter must be set to be equal with the rated primary CT current. If the parameter is set to "sec", the measuring value is shown as a multiple of the rated secondary CT current.

Example:

The current transformer used is of 1500/5 A. The flowing current is 1380 A. The parameter is set to 1500 A and on the display "1380 A" are shown. If the parameter is set to "sec", the value shown on the display is "0.92" x In.

Note:

The pick-up value is set to a multiple of the rated secondary CT current.

5.3.2 Display of earth current as primary quantity (I_{prim} earth)

The parameter of this function is to be set in the same way as that described under 5.3.1.

5.3.3 Display of residual voltage UE as primary quantity ($U_{\text{prim}}/U_{\text{sec}}$)

The residual voltage can be shown as primary measuring value. For this parameter the transformation ratio of the VT has to be set accordingly. If the parameter is set to "sec", the measuring value is shown as rated secondary voltage.

Example:

The voltage transformer used is of 10 kV/100 V. The transformation ratio is 100 and this value has to be set accordingly. If still the rated secondary voltage should be shown, the parameter is to be set to 1.

5.3.4 Voltage transformer connection for residual voltage measuring (3pha/e-n/1:1)

Depending on the connection of the voltage transformer of ER/XR-relay types three possibilities of the residual voltage measurement can be chosen (see chapter 4.6).

5.3.5 Nominal frequency

The adapted FFT-algorithm requires the nominal frequency as a parameter for correct digital sampling and filtering of the input currents.

By pressing <SELECT> the display shows "f=50" or "f=60". The desired nominal frequency can be adjusted by <+> or <-> and then stored with <ENTER>.

5.3.6 Display of the activation storage (FLSH/NOFL)

If after an activation the existing current drops again below the pickup value, e.g. I>, without a trip has been initiated, LED I> signals that an activation has occurred by flashing fast. The LED keeps flashing until it is reset again (push button <RESET>). Flashing can be suppressed when the parameter is set to NOFL.

5.3.7 Parameter switch/external triggering of the fault recorder

By means of the parameter-change-over switches it is possible to activate two different parameter sets. Switching over of the parameter sets can either be done by means of software or via the external inputs RESET or blocking input. Alternatively, the external inputs can be used for Reset or blocking of the triggering of the fault recorder.

Software-parameter	Blocking input used as	RESET input used as
SET1	Blocking input	RESET input
SET2	Blocking input	RESET input
B_S2	Parameter switch	RESET input
R_S2	Blocking input	Parameter switch
B_FR	External triggering of the fault recorder	RESET input
R_FR	Blocking input	External triggering of the fault recorder
S2_FR	Parameter switch	External triggering of the fault recorder

With the settings SET1 or SET2 the parameter set is activated by software. Terminals C8/D8 and D8/E8 are then available as external reset input or blocking input.

With the setting B_S2 the blocking input (D8, E8) is used as parameter-set change-over switch. With the setting R_S2 the reset input (D8, E8) is used as parameter-set changeover switch. With the setting B_FR the fault recorder is activated immediately by using the blocking input. On the front plate the LED FR will then light up for the duration of the recording. With the setting R_FR the fault recorder is activated via the reset input. With the setting S2_FR parameter set 2 can be activated via the blocking input and/or the fault recorder via the reset input.

The relevant function is then activated by applying the auxiliary voltage to one of the external inputs.

Important note:

When functioning as parameter change over facility, the external input RESET is not available for resetting. When using the external input BLOCKING the protection functions must be deactivated by software blocking separately (refer to chapter 5.7.1).

5.4 Protection parameters

5.4.1 Pickup value of the thermal overload protection $I_{B,A}$ and $I_{B,T}$

For basic current I_B , the max. permissible operating current or optionally the rated current of the object to be protected has to be used in either case based on rated secondary quantities. 100% of the thermal equivalent ϑ then corresponds to the max. permissible operating temperature or optionally to the rated operating temperature.

Conversion to secondary values are to be done as per the following formula:

$$I^B = \frac{I_{B,prim}}{n_l} \cdot \frac{1}{I_{N,MRI}}$$

with $I_{B,prim}$: max. base current in A
 n_l : c.t. ratio
 $I_{N,MRI}$: rated current

Example:

$$I_{B,prim} = 450; n_l = \frac{500A}{1A}; I_{N,MRI} = 1A$$

$$I_B = \frac{450A}{500} \cdot \frac{1}{1A} 0.9$$

5.4.2 Constant k

Constant k describes the admissible overload factor. This factor changes the pickup value and the tripping value of the relay.

5.4.3 Energizing delay (time) for the thermal overload

In certain applications, like for example during start up of motors, the threshold value for the detection of the thermal overload $k \cdot I_B$ might be exceeded for a short time. The warning relay responds and the LEDs indicate energizing. This excitation signal remains activated even after completion of the startup period. Start of a motor being a normal procedure and not a malfunction, the detection of the energizing for the thermal overload can be delayed here. In case of frequent and permitted over-load (i.e. for crushers) it might be reasonable to operate this overload with delay.

5.4.4 Time constant τ

Details on the time constants τ_C and τ_W can either be taken from the electrical equipment's data sheets or estimated on the base of practical values.

Additional influencing factors are a.o. the environmental heat storing and heat conducting capacity (e.g. mode of cable laying on the ground, in tubes or shafts, or the additional cooling by forced Convection of transformers through fans).

5.4.5 Pickup current for phase over current element (I_s)

The setting value for this parameter that appears on the display is related to the nominal current (I_N) of the relay. This means: pickup current (I_s) = displayed value x nominal current (I_N) e.g. displayed value = 1.25 then, $I_s = 1.25 \times I_N$.

5.4.6 Time current characteristics for phase overcurrent element (CHAR I>)

By setting this parameter, one of the following 6 messages appears on the display:

DEFT	-	Definite time
NINV	-	Normal inverse
VINV	-	Very inverse
EINV	-	Extremely inverse
RINV	-	RI-Inverse
LONG	-	Long Time Inverse

Anyone of these four characteristics can be chosen by using <+> <->-pushbuttons, and can be stored by using <ENTER>-pushbutton.

5.4.7 Trip delay or time multiplier for phase over current element (tl>)

Usually, after the characteristic is changed, the time delay or the time multiplier should be changed accordingly. In order to avoid an unsuitable arrangement of relay modes due to carelessness of the operator, the following precautions are taken:

After the characteristic setting, the setting process turns to the time delay setting automatically. The LED tl> is going to flash yellow to remind the operator to change the time delay setting accordingly. After pressing the <SELECT>-pushbutton, the present time delay setting value is shown on the display. The new setting value can then be changed by using <+> <-> -pushbuttons.

If, through a new setting, another relay characteristic other than the old one has been chosen (e.g. from DEFT to NINV), but the time delay setting has not been changed despite the warning from the flashing LED, the relay will be set to the most sensitive time setting value of the selected characteristics after five minutes warning of flashing LED tl>. The most sensitive time setting value means the fastest tripping for the selected relay characteristic. When the time delay or the time multiplier is set out of range (Text "EXIT" appears on the display), the low set element of the over current relay is blocked. The "WARN"-relay will not be blocked.

5.4.8 Reset setting for inverse time tripping characteristics in the phase current path

To ensure tripping, even with recurring fault pulses shorter than the set trip delay, the reset mode for all tripping characteristics can be switched over. If the adjustment tRST is set at 60 s, the tripping time is only reset after 60 s faultless condition. This function is not available if tRST is set to 0. With fault current cease the trip delay is reset immediately and started again at recurring fault current.

5.4.9 Current setting for high set element (I>>)

The current setting value of this parameter appearing on the display is related to the nominal current of the relay. This means: $I_{>>} = \text{displayed value} \times I_N$. When the current setting for high set element is set out of range (on display appears "EXIT"), the over current high set element is blocked.

5.4.10 Trip delay for high set element (tl>>)

Independent from the chosen tripping characteristic for I>, the high set element I>> has always a definite-time tripping characteristic. An indication value in seconds appears on the display.

5.4.11 Pickup value for residual voltage U_E (ITER-relay type)

Regardless of the preset earth current, an earth fault is only identified if the residual voltage exceeds the set reference value. This value is indicated in volt.

5.4.12 Pickup current for earth fault element ($I_{E>}$)

(Similar to 5.4.5)

5.4.13 WARN/TRIP changeover

An earth fault can be parameterized as follows:

- a) "warn" only the alarm relay trips
- b) "TRIP" the trip relay trips and tripping values are stored.

5.4.14 Time current characteristics for earth fault element (CHAR IE) (not ER device type)

By setting this parameter, one of the following 7 messages appears on the display:

DEFT	-	Definite Time (independent over current time protection)
NINV	-	Normal inverse (Type A)
VINV	-	Very inverse (Type B)
EINV	-	Extremely inverse (Type C)
RINV		RI-Inverse
LINV		Long Time Inverse
RXID		Special characteristic

Anyone of these four characteristics can be chosen by using <+> <->-pushbuttons, and can be stored by using <ENTER>-pushbutton.

5.4.15 Trip delay or time multiplier for earth fault element ($t_{IE>}$)

(Similar to 5.4.7)

5.4.16 Resetting time for inverse time earth fault element (not ER-relay type)

(Similar to 5.4.8)

5.4.17 Current setting for high set element of earth fault supervision ($I_{E>>}$)

(Similar to 5.4.9)

5.4.18 Trip delay for high set element of earth fault supervision ($t_{IE>>}$)

(Similar to 5.4.10)

5.4.19 COS/SIN Measurement (ER - relay type)

Depending on the neutral earthing connection of the protected system the directional element of the earth fault relay must be preset to $\cos \varphi$ or $\sin \varphi$ measurement.

By pressing <SELECT/RESET> the display shows "COS" resp. "SIN". The desired measuring principle can be selected by <+> or <-> and must be entered with password.

5.4.20 Block/Trip – time (only ITE-device type)

The block/trip time serves for detection of a c.b. failure protection by rear interlocking. It is activated by setting the blocking input D8/E8 and by setting the parameter to TR_B. After the set block/trip time has expired, the relay can be tripped if the excitation of a protective function has been applied the delay time of which has expired and the blocking function is still active. If the parameter PR_B is set, the individual protection stages are blocked (refer to Chapter 5.7.1).

5.4.21 Circuit breaker failure protection t_{CBFP}

The CB failure protection is based on supervision of phase currents during tripping events. Only after tripping this protective function becomes active. The test criterion is whether all phase currents are dropped to $<1\% \times I_N$ within t_{CBFP} (Circuit Breaker Failure Protection - adjustable between 0.1 - 2.0 s). If not all of the phase currents have dropped to $<1\% \times I_N$ within this time, CB failure is detected and the related relay activated. The CB failure protection function is deactivated again as soon as the phase currents have dropped to $<1\% \times I_N$ within t_{CBFP} .

5.4.22 Adjustment of the slave address

Pressing pushbuttons <+> and <-> the slave address can be set in range of 1-32.

5.4.23 Setting of Baud-rate (applies for Modbus Protocol only)

Different transmission rates (Baud rate) can be set for data transmission via Modbus Protocol. The rate can be changed by push buttons <+> and <-> and saved by pressing <ENTER>.

5.4.24 Setting of parity (applies for Modbus Protocol only)

The following three parity settings are possible :

- "even" = even
- "odd" = odd
- "no" = no parity check

The setting can be changed by push buttons <+> and <-> and saved by pressing <ENTER>.

5.5 Fault recorder

5.5.1 Adjustment of the fault recorder

The MRI3-ITE is equipped with a fault recorder (see chapter 3.2.3). Three parameters can be determined.

5.5.2 Number of the fault recordings

The max. recording time is 16 s at 50 Hz or 13.33 s at 60 Hz.

The number of max. recordings requested has to be determined in advance. There is a choice of (1)* 2, (3)* 4 or (7)* 8 recordings and dependent on this the duration of the individual fault recordings is defined, i.e.

(1)* 2 recordings for a duration of 8 s (with 50 Hz) (6.66 s with 60 Hz)

(3)* 4 recordings for a duration of 4 s (with 50 Hz) (3.33 s with 60 Hz)

(7)* 8 recordings for a duration of 2 s (with 50 Hz) (1.66 s with 60 Hz)

* is written over when a new trigger signal arrives

5.5.3 Adjustment of trigger occurrences

There is a choice between four different occurrences:

P_UP (Pickup)	Storage is initiated after recognition of a general activation
TRIP	Storage is initiated after a trip has occurred
A_PI (After Pickup)	Storage is initiated after the last activation threshold was fallen short of.
TEST	Storing is activated by simultaneous actuation of the keys <+> and <->. During the recording time the display shows "Test".

5.5.4 Pre-trigger time (T_{pre})

By the time T_{pre} it is determined which period of time prior to the trigger occurrence should be stored as well. It is possible to adjust a time between 0.05 s and 8 s. With keys <+> and <-> the values can be changed and with <ENTER> be saved.

5.6 Adjustment of the clock

When adjusting the date and time, LED ☉ lights up. The adjustment method is as follows:

Date:	Year	Y=00
	Month	M=00
	Day	D=00
Time:	Hour	h=00
	Minute	m=00
	Second	s=00

The clock starts with the set date and time as soon as the supply voltage is switched on. The time is safeguarded against short-term voltage failures (min. 6 minutes).

Note:

The window for parameter setting is located behind the measured value display. The parameter window can be accessed via the <SELECT/RESET> key.

5.7 Additional functions

5.7.1 Blocking of the protective functions

Blocking of the protective functions:

The MRI3-ITE(R) is equipped with a blocking function that can be parameterized arbitrary. Connecting supply voltage to terminals D8/E8 blocking of those functions which were selected by the user takes place.

It is possible to choose between two types of protective blocking:

1. Blocking of the individual protection stages. The excitation of the blocked protection stage is blocked..
2. *) Blocking of the individual tripping stages. The individual protection stages are excited and the set tripping time expires. Tripping only takes place when:
 - a) the voltage at the blocking input D8/E8 is reduced;
 - b) the voltage at the blocking input D8/E8 is applied, the tripping time and the blocking time have expired. (refer to Chapter 5.4.20)

Parameter setting is to be carried out as follows:

- *) After the <ENTER> and <TRIP> keys have been actuated simultaneously, the display shows the text "PR_B" (the protection stages are blocked) or "TR_B" (the tripping stages are blocked).
- *) The settings can be changed by actuating the keys <+> or <->. In this procedure, the LEDs l>; l>>; lE>; lE>> are simultaneously alight in case of protective blocking "PR_B" and LEDs tI>; tI>>; tIE>; tIE>> simultaneously emit light in case of trip blocking "TR_B".
- Actuation of the <ENTER> key with a one-time entry of the password will store the set function.
- After this actuate the <SELECT/RESET> key to call up the first blockable protection function.
- The display will show the text "BLOC" (the respective function is blocked) or "NO_B" (the respective function is not blocked).
- Actuation of the <ENTER> key will store the set function.
- By pressing the <SELECT/RESET> pushbutton, all further protective function that can be blocked are called one after the other.
- After selection of the last blocking function renewed pressing of the <SELECT/RESET> pushbutton switches to the assignment mode of the output relays.

*) Only MRI3-IT/ITE

Function		Display	LED/Colour
l _{B,A}	Temperature	NO_B	l _{B,A} red
l _{B,T}	Temperature	NO_B	l _{B,T} red
l>	Over current	NO_B	l> red
l>>	Short circuit	BLOC	l>> red
lE>	Earth current First element	NO_B	lE> red
lE>>	Earth current Second element	NO_B	lE>> red
tCBFP	Circuit breaker failure protection	NO_B	CB yellow

Table 5.3: Defaults settings of blocking functions

Assignment to the output relays:

Unit MRI3-ITE has five output relays. The fifth out-put relay is provided as permanent alarm relay for self supervision is normally on. Output relays 1 - 4 are normally off and can be assigned as alarm or tripping relays to the frequency functions which can either be done by using the pushbuttons on the front plate or via serial interface RS485. The assignment of the output relays is similar to the setting of parameters, however, only in the assignment mode. The assignment mode follows the blocking mode.

The relays are assigned as follows:

LEDs I_{B,A}, I_{B,T}, I>, I>>, I_{E>} and I_{E>>} are two-colored and light up green when the output relays are assigned as alarm relays and red as tripping relays.

Definition:

Alarm relays are activated at pickup of the relay.

Tripping relays are only activated after elapse of the tripping delay.

After the relay assignment mode has been activated the LED I> lights up green. Now one or several of the four output relays can be assigned to element I> as alarm relays. At the same time the selected alarm relays for element I> are indicated on the display. Indication "1 _ _ _" means that out-put relay 1 is assigned to this current element. When the display shows " _ _ _ _", no alarm relay is assigned to this current element.

The assignment of output relays 1 - 4 can be changed by pressing <+> and <-> pushbuttons. The selected assignment can be stored by pressing pushbutton <ENTER> and subsequent input of the password. By pressing pushbutton <SELECT/RESET>, LED I> lights up red. The out-put relays can now be assigned to this current element as tripping relays.

Relays 1-4 for the other elements are selected in the same way as described before. The assignment mode can be terminated at any time by pressing the <SELECT> pushbutton for some time (abt. 3 s).

Note:

- The function of jumper J2 described in general description "MR Digital Multifunctional Relays" has no function. For relays without assignment mode this jumper is used for parameter setting of alarm relays (activation at pickup or tripping). A form is attached to this description where the setting requested by the customer can be filled-in.

Relay function		Output relays				Display- indication	Corresponding LED
		1	2	3	4		
I _{B,A} k _A	Alarm Trip	X	X			_ 2 _ _ 1 _ _ _	I _{>} : green tI _{>} : red
I _{B,T} k _T	Alarm Trip	X	X			_ 2 _ _ 1 _ _ _	I _{>} : green tI _{>} : red
I _{>} tI _{>}	Alarm Trip	X	X			_ _ 3 _ 1 _ _ _	I _{>} ; →← green tI _{>} ; →← green
I _{>>} tI _{>>}	Alarm Trip	X		X		_ _ 3 _ 1 _ _ _	I _{>>} ; →← green tI _{>>} ; →← green
I _{E>} (V) tI _{E>} (V)	Alarm Trip	X			X	_ _ _ 4 1 _ _ _	I _{E>} ; →← green tI _{E>} ; →← green
I _{E>} (R) tI _{E>} (R)	Alarm Trip	X			X	_ _ _ 4 1 _ _ _	I _{E>} ; →← red tI _{E>} ; →← red
I _{E>>} (V) tI _{E>>} (V)	Alarm Trip	X			X	_ _ _ 4 1 _ _ _	I _{E>>} ; →← green tI _{E>>} ; →← green
I _{E>>} (R) tI _{E>>} (R)	Alarm Trip	X			X	_ _ _ 4 1 _ _ _	I _{E>>} ; →← red tI _{E>>} ; →← red
tCBFP	Trip					_ _ _ _	C.B. red

Table 5.4: Example of assignment matrix of the output relays (default settings)

V = Forward

R = Backward

5.8 Indication of measuring and fault values

5.8.1 Indication of measuring values

The following measuring quantities can be indicated on the display during normal service:

- Apparent Current in phase 1 (LED L1 green)
- Apparent Current in phase 2 (LED L2 green)
- Apparent Current in phase 3 (LED L3 green)
- Temperature equivalent $\vartheta_{A>}$ in % (LED ϑ_A yellow), (for MRI3-ITE)
- Temperature equivalent $\vartheta_{T>}$ in % (LED ϑ_T red), (for MRI3-ITE)
- Temperature equivalent $\vartheta_{A>}$ in % (LED $\vartheta_{>}$ green), (for MRI3-ITER)
- Temperature equivalent $\vartheta_{T>}$ in % (LED $\vartheta_{>}$ red), (for MRI3-ITER)
- Time until release ϑ_T in s (LED ϑ_T red), (for MRI3-ITE)
- Time until release ϑ_T in s (LED $\vartheta_{>}$ red), (for MRI3-ITER)
- Apparent earth current (LED E green)
- Active earth current (LED E and I_P green) *
- Reactive earth current (LED E and I_Q green) *
- Residual voltage U_E (LED U_E) only at ITER-relay type
- Angle between I_E and U_E (only at ITER relay type)

5.8.2 Unit of the measuring values displayed

The measuring values can optionally be shown in the display as a multiple of the "sec" rated value (xI_n) or as primary current (A). According to this the units of the display change as follows:

Phase current

Indication as	Range	Unit
Secondary current	0.00 – 40.0	$x I_n$
Active portion I_P	± 0.00 – 40	$x I_n$
Reactive portion I_Q	± 0.00 – 40.	$x I_n$
Primary current	.000 – 999.	A
	k000 – k999	kA*
	1k00 – 9k99	kA
	10k0 – 99k0	kA
	100k – 999k	kA
	1M00 – 2M00	MA

Earth current

Indication as	Range	Unit
Secondary current	.000 – 15.0	$x I_n$
Active portion I_P	± 0.00 – 40	$x I_n$
Reactive portion I_Q (E/SR/ER types)	± 0.00 – 40.	$x I_n$
Secondary current	0.00 - 150	% I_N
Active portion I_P	± 0.00 – 150	% I_N
Reactive portion I_Q (X/XR types)	± 0.00 – 150	% I_N
Primary earth current	.000 – 999.	A
	k000 – k999	kA*
	1k00 – 9k99	kA
	10k0 – 99k0	kA
	100k – 999k	kA
	1M00 – 2M00	MA

Earth voltage

Indication as	Range	Unit
Sec. voltage	000V – 999V	V
Primary voltage	.000 – 999	kV
	1K00 – 9K99	kV
	10K0 – 99K0	kV
	100K – 999K	kV
	1M00 – 9M99	MV

5.8.3 Indication of fault data

All faults detected by the relay are indicated on the front plate optically. For this purpose, the four LEDs (L1, L2, L3, E) and the four function LEDs (I>, I>>, IE>, IE>>) and →←) are equipped at MRI3-ITER. If, for example an over current occurs, first the each phases will light up. LED I> lights up at the same time. After tripping the LEDs are lit permanently.

5.8.4 Fault memory

When the relay is energized or trips, all fault data and times are stored in a non-volatile memory manner. The MRI3 is provided with a fault value recorder for max. eight fault occurrences. In the event of additional trippings always the oldest data set is written over.

For fault indication not only the trip values are re-corded but also the status of LEDs. Fault values are indicated when push buttons <-> or <+> are pressed during normal measuring value indication.

- Normal measuring values are selected by pressing the <SELECT/RESET> button.
- When then the <-> button is pressed, the latest fault data set is shown. By repeated pressing the <-> button the last but one fault data set is shown etc. For indication of fault data sets abbreviations FLT1, FLT2, FLT3, ... are displayed (FLT1 means the latest fault data set recorded). At the same time the parameter set active at the occurrence is shown.
- By pressing <SELECT/RESET> the fault measuring values can be scrolled.
- By pressing <+> it can be scrolled back to a more recent fault data set. At first FLT8, FLT7, ... are always displayed. When fault recording is indicated (FLT1 etc), the LEDs flash in compliance with the stored trip information, i.e. those LEDs which showed a continuous light when the fault occurred are now blinking to indicate that it is not a current fault. LEDs which were blinking during trip conditions, (element had picked up) just briefly flash.
- If the relay is still in trip condition and not yet reset (TRIP is still displayed), no measuring values can be shown.
- To delete the trip store, the push button combination <SELECT/RESET> and <-> has to be pressed for about 3s. The display shows "wait".

5.9 Reset

Unit MRI3-ITER has the following three possibilities to reset the display of the unit as well as the output relay at jumper position J3=ON.

Manual Reset

- Pressing the pushbutton <SELECT/RESET> for some time (about 3 s)

Electrical Reset

- Through applying auxiliary voltage to C8/D8

Software Reset

- The software reset has the same effect as the <SELECT/RESET> pushbutton (see also communication protocol of RS485 interface).
The display can only be reset when the pickup is not present anymore (otherwise "TRIP" remains in display).
During resetting of the display the parameters are not affected.

5.9.1 Erasure of fault storage

The fault storage is erased by pressing the key combination <SELECT/RESET> and <-> for about 3 s. At the display "Wait" appears.

5.9.2 Reset of the thermal replica register

It is possible to reset the thermal replica ϑ to 0%.

- The thermal replica is reset by long pressing of the pushbuttons <SELECT/RESET> and <-> (for approx. 3 seconds).

6. Relay testing and commissioning

The test instructions following below help to verify the protection relay performance before or during commissioning of the protection system. To avoid a relay damage and to ensure a correct relay operation, be sure that:

- The auxiliary power supply rating corresponds to the auxiliary voltage on site.
- The rated current of the relay corresponds to the plant data on site.
- The current transformers are connected to the relay correctly.
- All signal circuits and output relay circuits are connected correctly.

6.1 Power-On

Note!

Prior to switch on the auxiliary power supply, be sure that the auxiliary supply voltage corresponds with the rated data on the type plate.

Switch on the auxiliary power supply to the relay and check that the message "WW" appears on the display and the self supervision alarm relay (watchdog) is energized (Contact terminals D7 and E7 closed).

6.2 Testing the output relays and LEDs

NOTE!

Prior to commencing this test, interrupt the trip circuit to the circuit breaker if tripping is not desired. By pressing the pushbutton <TRIP> once, the display shows the first part of the software version of the relay (e.g. „D21-“). By pressing the pushbutton <TRIP> twice, the display shows the second part of the software version of the relay (e.g. „1.00“). The software version should be quoted in all correspondence. Pressing the <TRIP> button once more, the display shows "PSW?". Please enter the correct password to proceed with the test. The message "TRI?" will follow. Confirm this message by pressing the pushbutton <TRIP> again. All out-put relays and LEDs should then be activated and the self supervision alarm relay (watchdog) be de-activated one after another with a time interval of 3 seconds. Thereafter, reset all output relays back to their normal positions by pressing the pushbutton <SELECT/RESET> (about 3 s).

6.3 Checking the set values

By repeatedly pressing the pushbutton <SELECT>, all relay set values may be checked. Set value modification can be done with the pushbutton <+><-> and <ENTER>. For detailed information about that, please refer to chapter 5.

For a correct relay operation, be sure that the frequency set value ($f=50/60$) has been selected according to your system frequency (50 or 60 Hz).

6.4 Secondary injection test

6.4.1 Test equipment

- Ammeter with class 1 or better,
- auxiliary power supply with the voltage corresponding to the rated data on the type plate,
- single-phase current supply unit (adjustable from 0 to $\geq 4 \times I_N$),
- timer to measure the operating time (Accuracy class $\leq \pm 10$ ms),
- switching device and
- test leads and tools

6.4.2 Example of test circuit for MRI3-ITE

For testing MRI3-ITE relays only current input signals are required. Figure 6.1 shows a simple example of a single phase test circuit with adjustable current energizing the MRI3-ITE relay under test.

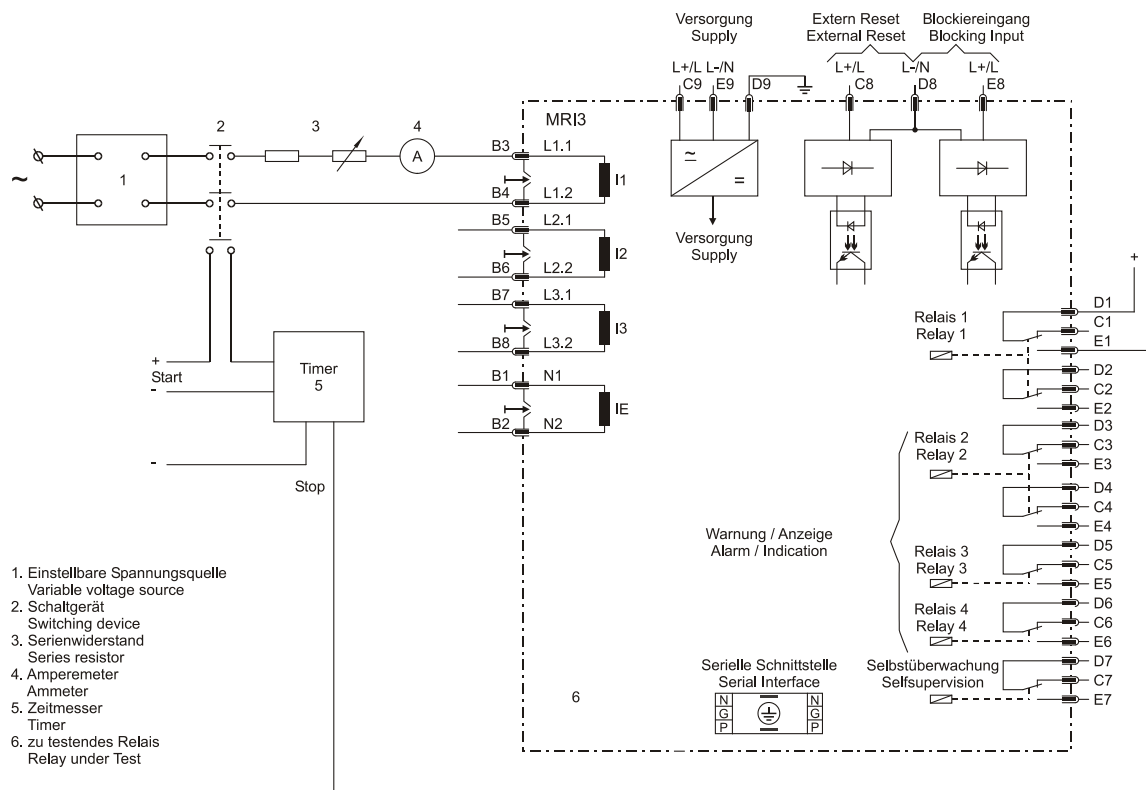

Figure 6.1: Test circuit

6.4.3 Checking the input circuits and measured values

Inject a current, which is less than the relay pickup current set values, in phase 1 (terminals B3-B4), and check the measured current on the display by pressing the pushbutton <SELECT/RESET>. For a relay with rated current $I_N = 5$ A, for example, a secondary current injection of 1 A should be indicated on the display with about $(0.2 \times I_N)$. When parameter $I_{prim} = „s“$ is set, the indication is $0.2 \times I_N$ and at „5“ the indication is 1.00 [A]. The current can be also injected into the other current input circuits (Phase 2: terminals B5-B6, Phase 3: terminals B7-B8, Earth current: terminals B1-B2) in the same manner. Compare the displayed current value with the reading of the ammeter. The deviation must not exceed 33%. General hint: When checking the individual tripping functions, it would be advisable to release only those parameters which shall be tested. Set parameters to „EXIT“, since otherwise there might be tripping of several protective functions. Attention must also be paid to the fact that - for this protective function - the „correct“ output relay will be assigned.

Example: The tripping value of the phase over current is to be tested and the test circuit's structure is the same as above. In this case, in the assignment mode, relay 1 is assigned to the function tl>.

6.4.4 Example of a test circuit with earth fault directional feature

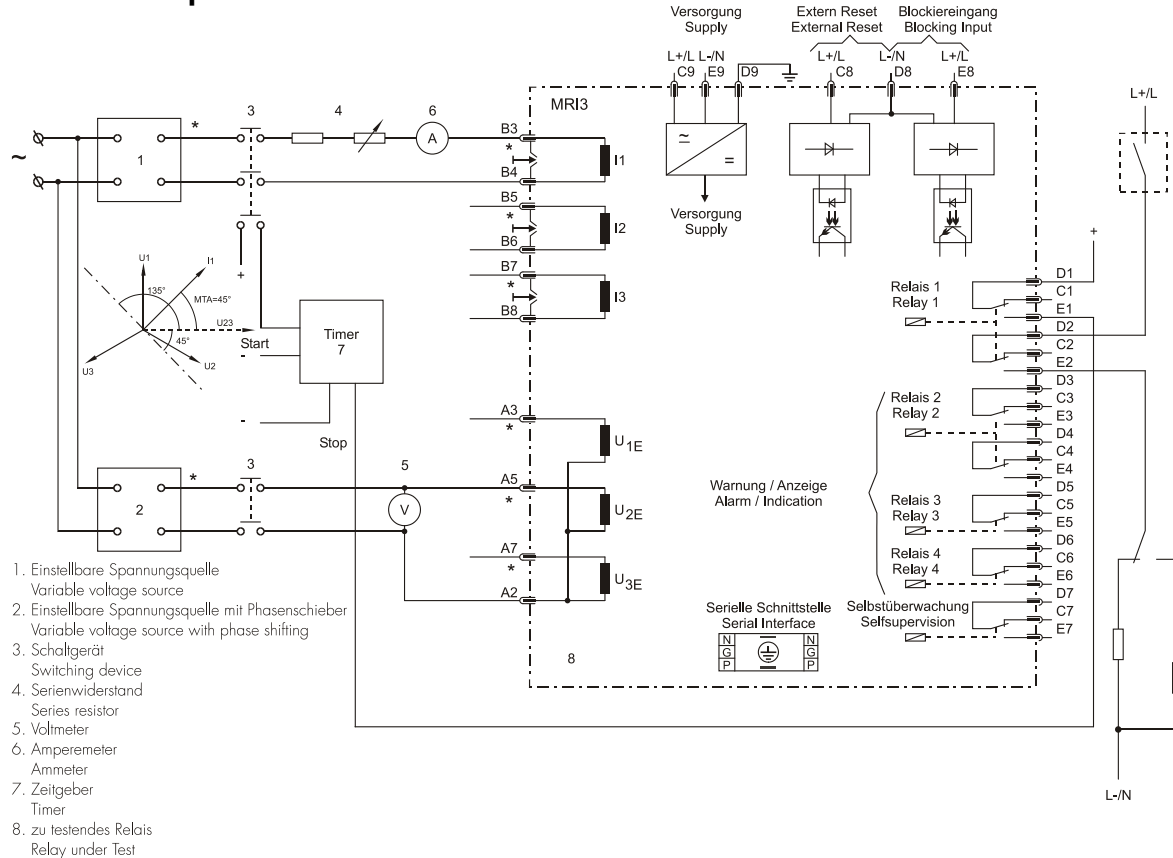

Figure 6.2: Test circuit

For testing MRI3-ITER relays with earth fault directional feature, current and voltage sources are required, with one of the two sources having to be equipped with a phase shifter.

Fig. 6.2 shows an example of a test circuit with variable current and voltage sources. First, the parameters $I_{E>}$ and $I_{E>>}$ must be set to "EXIT" in order to prevent possible tripping. For the purpose of testing the directional feature, a test voltage equal to the rated voltage is applied to terminals A2/A5. The parameter "Voltage transformer connection for residual voltage measuring" (refer to 5.3.4) must be adjusted to "3Pha".

The appropriate measuring value is selected via the <SELECT/RESET> key. The display must indicate 1/3 of the rated voltage ($\pm 0.5\% U_n$). Now a current of $0.4 \times I_N$ is injected (terminals B1/B2). The display must now indicate a value of 0.40 ($\pm 3\%$).

Finally, using the phase shifter, it must be checked whether the setting of the testing equipment coincides with the indication on the display ($\pm 3^\circ$).

By using an RMS-metering instrument, a greater deviation may be observed if the test current contains harmonics. Because the MRI3-ITER relay measures only the fundamental component of the input signals, the harmonics will be rejected by the internal DFFT-digital filter. Whereas the RMS-metering instrument measures the RMS-value of the input signals.

6.4.5 Checking the operating and resetting values of the relay

Inject a current which is less than the relay set values in phase 1 of the relay and gradually increase the current until the relay starts, i.e. at the moment when the LED I> and L1 light up or the alarm out-put relay I> is activated. Read the operating current indicated by the ammeter. The deviation must not exceed 5% of the set operating value.

Furthermore, gradually decrease the current until the relay resets, i.e. the alarm output relay I> is disengaged. Check that the resetting current is not smaller than 0.97 times the operating current. Repeat the test on phase 2, phase 3 and earth current input circuits in the same manner.

6.4.6 Checking the relay operating time

To check the relay operating time, a timer must be connected to the trip output relay contact. The timer should be started simultaneously with the current injection in the current input circuit and stopped by the trip relay contact. Set the current to a value corresponding to twice the operating value and inject the current instantaneously. The operating time measured by the timer should have a deviation of less than 3% of the set value or <20 ms.

Repeat the test on the other phases or with the inverse time characteristics in the similar manner. In case of inverse time characteristics the injected current should be selected according to the characteristic curve, e.g. two times I_S. The tripping time may be read from the characteristic curve diagram or calculated with the equations given under "technical data".

Please observe that during the secondary injection test the test current must be very stable. Otherwise the test results may be wrong. This especially applies for currents smaller than 2 x I_S, where the trip delays are in the steep range of the inverse curves.

6.4.7 Checking the high set element of the relay

Set a current above the set operating value of I>>. Inject the current instantaneously and check that the alarm output relay I>> operates. Check the tripping time of the high set element according chapter 6.4.6

Check the accuracy of the operating current setting by gradually increasing the injected current until the I>> element picks up. Read the current value from the ammeter and compare with the desired setting.

Repeat the entire test on other phases and earth current input circuits in the same manner.

Note !

Where test currents >4 x I_N are used, the thermal withstand capability of the current paths has to be considered (see technical data, chapter 7.1)

6.4.8 Checking the external blocking and reset functions

By means of the external blocking input, it is possible to block all protective functions. To give an example, the blocking function of the phase current high set element is described.

This can be tested by first setting the parameter for the phase current high set element to „BLOC“ and then connecting the auxiliary voltage to terminals E8/D8.

The phase current low set element I> should be set to EXIT for this test. Inject a test current which could cause a high set (I>>) tripping. Observe that there is no trip of any assigned output relay of the high set or low set element.

Remove the auxiliary supply voltage from the blocking input. Inject a test current to trip the relay (message „TRIP“ on the display). Interrupt the test current and apply auxiliary supply voltage to the external reset input of the relay (terminals C8/D8). The display and LED indications should be reset immediately.

6.4.9 Testing the external blocking with Block/Trip function

In order to simplify things, the short-circuit stage is to be tested here as described in Chapter 6.4.7. For this purpose, the parameter for the Block/Trip function must be set to "TR_B" (first value in the blocking menu of the protection functions Chapter 5.7.1). The appertaining Block/Trip time should be longer than the set tripping time $t_{l>>}$. (Refer to Chapter 5.4.18). Here, too, a current is impressed which should make the short-circuit stage trip. After the Block/Trip time has expired, tripping will take place. Tripping takes place when:

- the blocking input has been set
- a tripping stage has been excited
- the appertaining tripping time has expired
- the Block/trip time has expired

If the Block/Trip time is set shorter than the tripping time, tripping will only take place after the tripping time has expired.

6.4.10 Test of the CB failure protection

For testing the tripping time a test current of about 2 times the rated current to be injected. The timer is started upon tripping of the relay of a protection function ($I>$, $I>>$, $IE>$, $IE>>$) and stopped as soon as the relay for the CB failure protection has picked up. Message "CBFP" is displayed. The tripping time ascertained by the timer should not deviate more than 1% or, at short trip delay, less than 10 ms from the set tripping time.

Alternatively, the timer can be started when the aux. voltage and the test current are injected simultaneously. The timer stops when the corresponding output relay for circuit breaker failure protection trips.

In this case the previously measured tripping delay has to be subtracted from the total tripping time measured.

6.5 Primary injection test

Generally, a primary injection test could be carried out in the similar manner as the secondary injection test described above. With the difference that the protected power system should be, in this case, connected to the installed relays under test „on line“, and the test currents and voltages should be injected to the relay through the current and voltage transformers with the primary side energized. Since the cost and potential hazards are very high for such a test, primary injection tests are usually limited to very important protective relays in the power system.

Because of its powerful combined indicating and measuring functions, the MRI3-ITER relay may be tested in the manner of a primary injection test without extra expenditure and time consumption.

In actual service, for example, the measured current values on the MRI3-ITER relay display may be compared phase by phase with the current indications of the ammeter of the switchboard to verify that the relay works and measures correctly.

6.6 Maintenance

Maintenance testing is generally done on site at regular intervals. These intervals vary among users depending on many factors: e.g. the type of protective relays employed; the importance of the primary equipment being protected; the user's past experience with the relay, etc.

For electromechanical or static relays, maintenance testing will be performed at least once a year according to the experiences. For digital re-lays like MRI3-ITER, this interval can be substantially longer. This is because:

- The MRI3-ITER relays are equipped with very wide self-supervision functions, so that many faults in the relay can be detected and signaled during service. Important: The self-supervision output relay must be connected to a central alarm panel!
- The combined measuring functions of MRI3-ITER relays enable supervision the relay functions during service.
- The combined TRIP test function of the MRI3-ITER relay allows to test the relay output circuits.

A testing interval of two years for maintenance will, therefore, be recommended.

During a maintenance test, the relay functions including the operating values and relay tripping characteristics as well as the operating times should be tested.

7. Technical data

7.1 Measuring circuits

Rated data:	Nominal current I_N	1 A or 5 A
	Nominal frequency f_N	50/60 Hz adjustable
Power consumption in current circuit:	at $I_N = 1\text{ A}$	0.2 VA
	at $I_N = 5\text{ A}$	0.1 VA
Power consumption in voltage circuit:	<1 VA	
Thermal withstand capability in current circuit:	dynamic current withstand (half-wave)	250 x I_N
	for 1 s	100 x I_N
	for 10 s	30 x I_N
	continuously	4 x I_N
Thermal withstand capability in voltage circuit:	continuously	1.5 x U_N

7.2 Common data

Dropout to pickup ratio:	>97%
Dropout to pickup ratio for phase current in range $0.2 \times I_N$ to $0.5 \times I_N$:	= 100 %
Returning time: 30 ms	
Time lag error class index E:	10 ms
Minimum operating time:	60 ms
Transient overreach at instantaneous operation:	≥5%
Permissible interruption of the supply voltage without influence on the function:	50 ms
Influences on the current measurement	
Auxiliary voltage:	In the range $0.8 < U_H / U_{HN} < 1.2$ no additional influences can be measured.
Frequency:	in the range $0.9 < f / f_N < 1.1$; <0.2% / Hz
Harmonics:	up to 20% of the third harmonic; <0.08% per percent of the third harmonic up to 20% of the fifth harmonic; <0.07% per percent of the fifth harmonic
Influences on delay times:	No additional influences can be measured.

For further technical data please refer to manual „MR-Multifunctional relays“.

7.3 Setting ranges and steps

7.3.1 Systemparameter

	Setting range	Step	Tolerance
I_{prim} L1 L2 L3 E	(SEK) 0.002... 50.0 kA	0.001 kA (0.002...0.200) 0.002 kA (0.200...0.500) 0.005 kA (0.500...1.00) 0.01 kA (1.00...2.00) 0.02 kA (2.00...5.00) 0.05 kA (5.00...10.0) 0.1 kA (10.0...20.0) 0.2 kA (20.0...50.0)	
$U_{e>} (U_{prim}/U_{sek})$	(SEK) 1.01...6500	0.01 (1.01...2.00) 0.02 (2.00...5.00) 0.05 (5.00...10.0) 0.1 (10.0...20.0) 0,2 (20,0...50,0) 0.5 (50.0...100.) 1.0 (100...200) 2.0 (200...500) 5.0 (500...1000) 10.0 (1000...2000) 20.0 (2000...5000) 50.0 (5000...6500)	
f_N	50/60 Hz		

Table 7.1: Setting values and steps

7.3.2 Overload protection

	Setting range	Step	Tolerance
$I_{B,Alarm}$	0.4...3.5 x I_N (EXIT)	0.02 x I_N (0.4...1.0) 0.05 x I_N (1.0...3.5)	±3% from set value or ±2.5% I_N
k_A	0.5...5	0.01 (0.5...1.0) 0.02 (1.0...2.0) 0.05 (2.0...5.0)	
$I_{B,Alarm}$	0.04 - 260 s (EXIT) (definite time)	0.02 (0.04...1.0) 0.05 (1.0...2.0) 0.1 (2.0...5.0) 0.2 (5.0...8.5) 0.5 (8,5...10.0) 1.0 (10...20) 2.0 (20...50) 5.0 (50...100) 10.0 (100...260)	±3% resp. ±20 ms
$I_{B,TRIP}$	0.4...3.5 x I_N (EXIT)	0.02 x I_N (0.4...1.0) 0.05 x I_N (1.0...3.5)	±3% from set value or ±2.5% I_N
k_T	0.5...5	0.01 (0.5...1.0) 0.02 (1.0...2.0) 0.05 (2.0...5.0)	
$I_{B,Trip}$	0.04 - 260 s (EXIT) (definite time)	0.02 (0.04...1.0) 0.05 (1.0...2.0) 0.1 (2.0...5.0) 0.2 (5.0...8.5) 0.5 (8,5...10.0) 1.0 (10...20) 2.0 (20...50) 5.0 (50...100) 10.0 (100...260)	±3% resp. ±20 ms
τ_W	0.5...180 min	0.1 (0.5...2) min 0.2 (2...5) min 0.5 (5...10) min 1 (10...20) min 2 (20...50) min 5 (50...100) min 10 (100...180) min	
τ_C	0.5...180 min	0.1 (0.5...2) min 0.2 (2...5) min 0.5 (5...10) min 1 (10...20) min 2 (20...50) min 5 (50...100) min 10 (100...180) min	

Table 7.2: Setting values and steps

7.3.3 Over current time protection

	Setting range	Step	Tolerance
$I_{>}$	0.2...4.0 x I_N (EXIT)	0.01 (0.2...0.5) 0.02 (0.5...1.0) 0.05 (1.0...2.0) 0.1 (2.0...4.0)	±3% from set value
$t_{I>}$	0.04 - 260 s (EXIT) (definite time) 0.05 - 20 (EXIT) (inverse time)	0.02 (0.04...1.0) 0.05 (1.0...2.0) 0.1 (2.0...5.0) 0.2 (5.0...8.5) 0.5 (8.5...10.0) 1.0 (10...20) 2.0 (20...50) 5.0 (50...100) 10.0 (100...260) 0.01 (0.05...0.5) 0.02 (0.5...1.0) 0.05 (1.0...2.0) 0.1 (2.0...5.0) 0.2 (5.0...10.0) 0.5 (10.0...20.0)	±3% or ±20 ms ±5% for NINV and VINV ±7,5% for NINV and EINV
$I_{>>}$	0.5...40 x I_N (EXIT)	0.02 (0.5...0.98) 0.05 (1.0...2.0) 0.1 (2.0...4.0) 0.2 (4.0...10.0) 0.5 (10.0...20.0) 1.0 (20.0...40.0)	±3% from set value
$t_{I>>}$	0.04...10 s (EXIT)	0.02 (0.04...0.5) 0.05 (0.5...2.0) 0.1 (2.0...5.0) 0.2 (5.0...10)	±3% or ±20 ms

Table 7.3: Setting values and steps

7.3.6 Determination of earth fault direction (MRI3-ITER)

Measurement of active current component for compensated systems:

$$I_E \times \cos \varphi$$

Measurement of reactive current component for isolated systems:

$$I_E \times \sin \varphi$$

Angle measuring accuracy:

$$\pm 3^\circ \text{ at } I_E \times \cos \varphi \text{ or } I_E \times \sin \varphi > 5 \% I_E$$

7.3.7 BlockTrip – time**

Block/Trip	0,1...2,0 s; EXIT	0,01; 0,02; 0,05; 0,1 s	±1% bzw. ±10 ms
------------	-------------------	-------------------------	-----------------

7.3.8 Switch failure protection

t _{CBFP}	0.1...2.0 s; EXIT	0.01; 0.02; 0.05; 0.1 s	±1% bzw. ±10 ms
-------------------	-------------------	-------------------------	-----------------

7.3.9 Interface parameter

*only Modbus Protocol

7.3.10 Parameter for the fault recorder

Function	Parameter	Adjustment example
FR	Number of recordings	(1)* 2 x 8 s; (3)* 4 x 4 s; (7)* 8 x 2 s (with 50 Hz) (1)* 2 x 6.66 s, (3)* 4 x 3.33 s, (7)* 8 x 1.66 s (60 Hz)
FR	Saving of the recording at the occurrence	P_UP; TRIP; A_PI; TEST
FR	Pre-trigger-time	0.05 s – 8.00 s

* is written over when a new trigger signal arrives

** only MRI3-ITE

7.4 Tripping characteristics

7.4.1 Thermal characteristic

From the equation for the temperature equivalent:

$$\vartheta(t) = \frac{I^2}{(k \cdot I_B)^2} \cdot 100\% + \left(\vartheta_0 - \frac{I^2}{(k \cdot I_B)^2} \cdot 100\% \right) \cdot e^{-t/\tau}$$

it is possible to deduce the tripping characteristics according to IEC 155-8. The temperature equivalent of the preload 0 equals the preload current IP:

$$\vartheta_0 = \frac{I_p^2}{(k \cdot I_B)^2} \cdot 100\%$$

Tripping is realized as soon as the temperature equivalent $\vartheta = k^2 \cdot 100\%$ is reached. This temperature equivalent equals a permanent load current of $k \cdot I_B$:

$$\vartheta_{\text{Trip}} = k^2 \cdot 100\%$$

$$\text{Trip} = k^2 \cdot 100\%$$

For the tripping characteristic:

$$\vartheta_{\text{TRIP}} = 100\% = \frac{I^2}{(k \cdot I_B)^2} \cdot 100\% + \left(\frac{I_p^2}{(k \cdot I_B)^2} \cdot 100\% - \frac{I^2}{(k \cdot I_B)^2} \cdot 100\% \right) e^{-\frac{t_{\text{TRIP}}}{\tau}}$$

or:

$$(k \cdot I_B)^2 = I^2 + (I_p^2 - I^2) \cdot e^{-\frac{t_{\text{aus}}}{\tau}}$$

- transpose to e^{ttrip}

$$e^{-\frac{t_{\text{trip}}}{\tau}} = \frac{(I_p^2 - I^2)}{((k \cdot I_B)^2 - I^2)} = \frac{(I^2 - I_p^2)}{(I^2 - (k \cdot I_B)^2)}$$

$$t_{\text{trip}} = \tau \cdot \ln \left[\frac{(I^2 - I_p^2)}{I^2 - (k \cdot I_B)^2} \right] = \tau \cdot \ln \left[\frac{\left(\frac{I^2}{I_B^2} - p^2 \right)}{\left(\frac{I^2}{I_B^2} - k^2 \right)} \right] \text{ mit } p = \frac{I_p}{I_B}$$

with

The result are the tripping characteristics according to IEC 255-8:

$$t_{\text{TRIP}} = \tau \cdot \ln \left[\frac{\left(\frac{I^2}{I_B^2} - p^2 \right)}{\left(\frac{I^2}{I_B^2} - k^2 \right)} \right] \text{ for } p^2 < \frac{I^2}{I_B^2} \cap p^2 \leq k^2$$

with τ = thermal time constant of the object to be protected
 I = relay current
 I_B = Basic current
 I_p = preload current
 p = preload factor ($p = 0$ means cold condition of the electrical item)
 k = constant

7.4.2 Preload factor

The normal tripping characteristic according to IEC 255-8:

$$t_{trip} = \tau \cdot \ln \left[\frac{\left(\frac{I^2}{I_B^2} - p^2 \right)}{\left(\frac{I^2}{I_B^2} - k^2 \right)} \right]$$

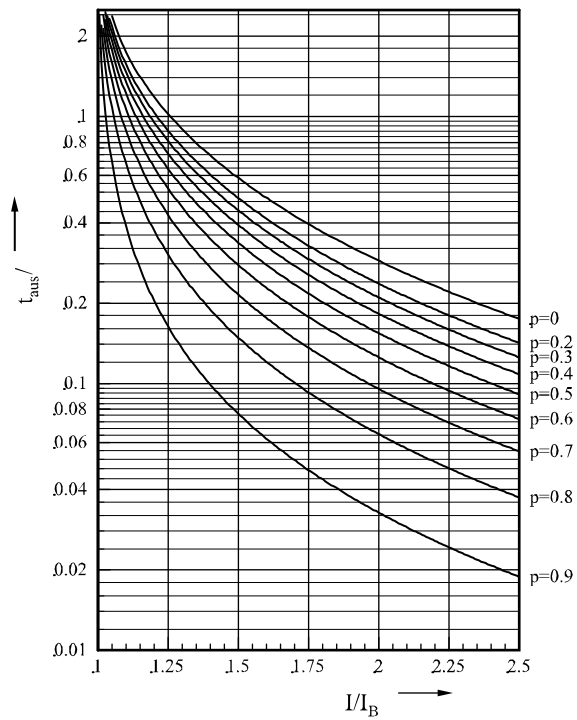

Figure 7.1: Tripping characteristics for various preload factors p and constant $k=1,0$.

7.4.3 Inverse time over current protection relay

According to IEC 255-4 or BS 142

Normal Inverse (type A)

$$t = \frac{0.14}{\left(\frac{I}{I_S}\right)^{0.02} - 1} \cdot t_I > [s]$$

Very Inverse (type B)

$$t = \frac{13.5}{\left(\frac{I}{I_S}\right) - 1} \cdot t_I > [s]$$

Extremely Inverse (type C)

$$t = \frac{80}{\left(\frac{I}{I_S}\right)^2 - 1} \cdot t_I > [s]$$

Long time inverse

$$t = \frac{120}{\left(\frac{I}{I_S}\right) - 1} \cdot t_I > [s]$$

RI-inverse

$$t = \frac{1}{0.339 - \frac{0.236}{\left(\frac{I}{I_S}\right)}} \cdot t_I > [s]$$

*RXIDG – characteristic

$$t = \left(5.8 - 1.35 \cdot \ln\left(\frac{I}{I_S}\right) \right) \cdot t_I > [s]$$

Where:

t	=	tripping time
tI>	=	time multiplier
I	=	fault current
I _S	=	Starting current
	=	natural logarithm

*only for earth current

7.5 Tripping characteristics

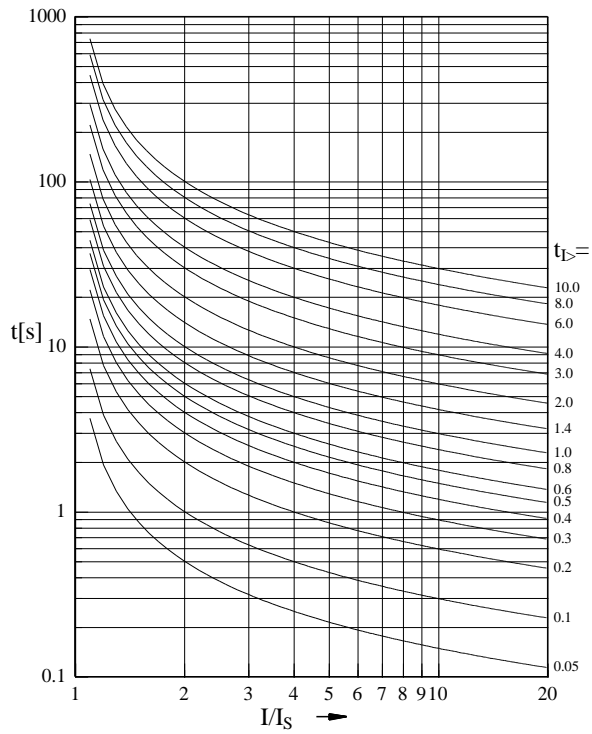

Figure 7.2: Normal Inverse

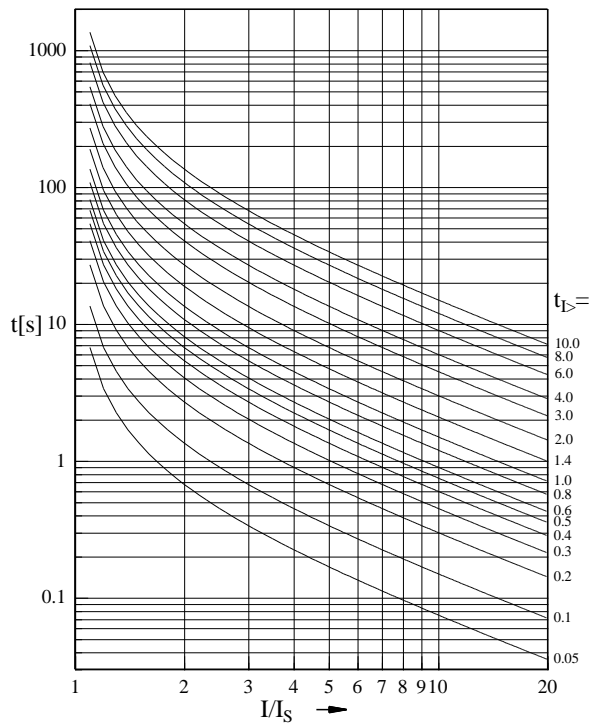

Figure 7.3: Very Inverse

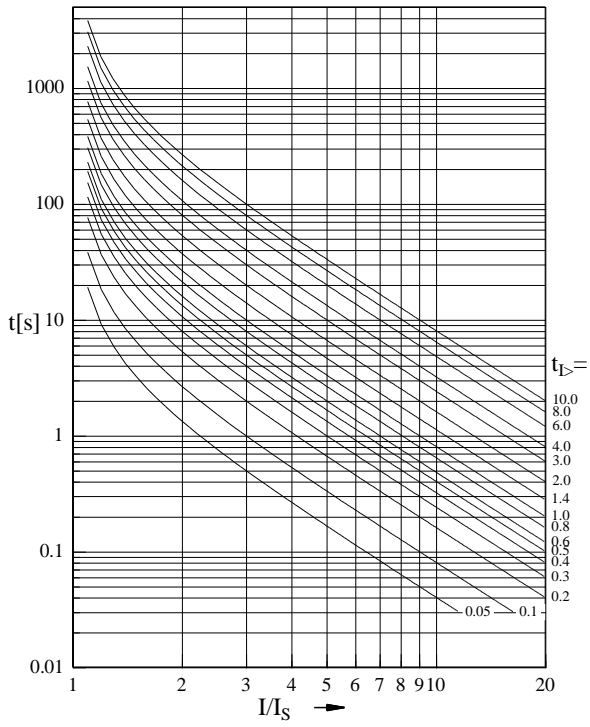

Figure 7.4: Extremely Inverse

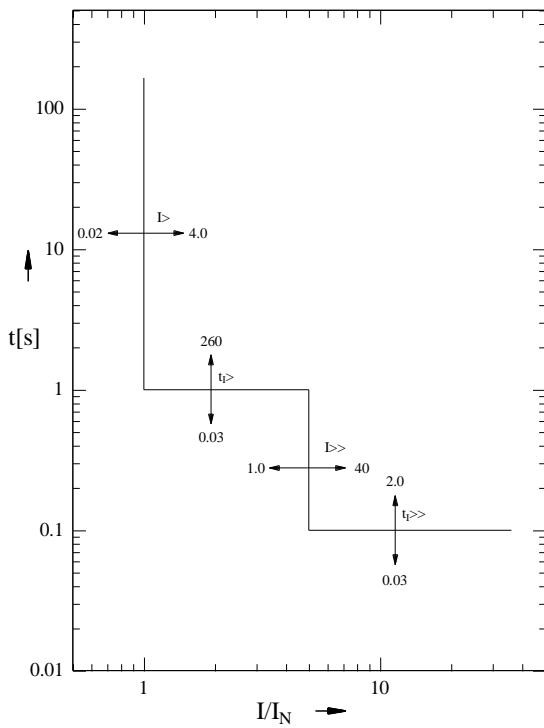

Figure 7.5: Definite time over current relay

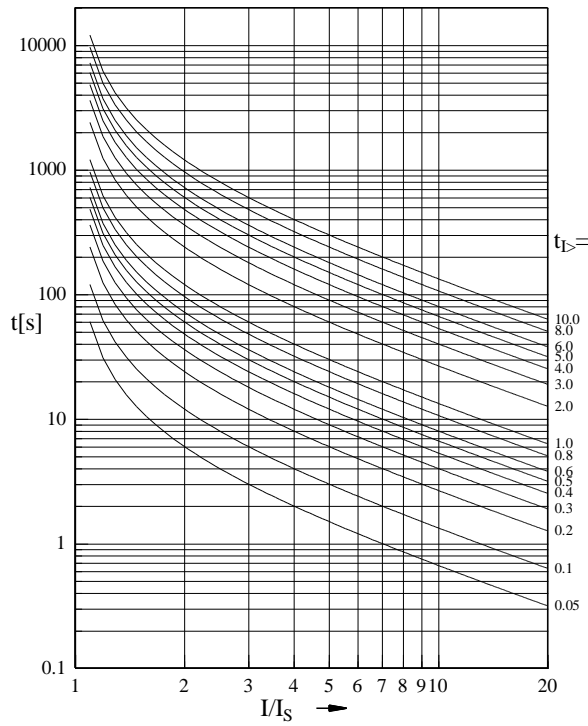

Figure 7.6: Long Time Inverse

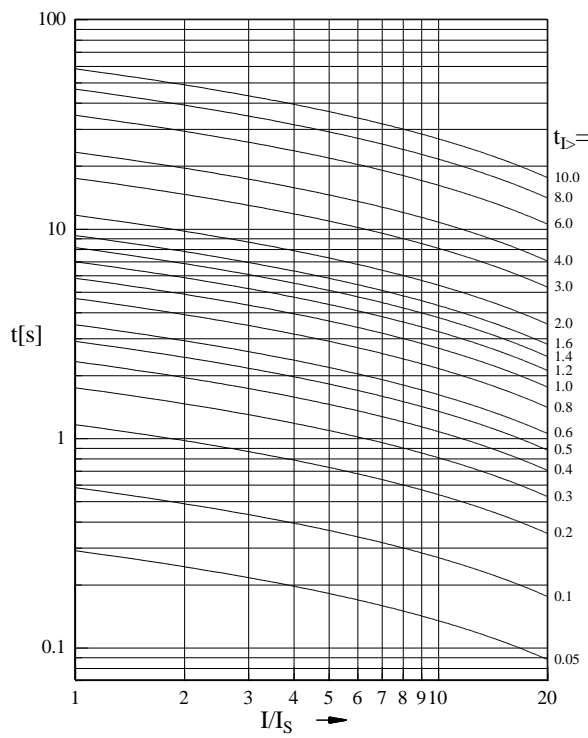

Figure 7.7: RXIDG-characteristic

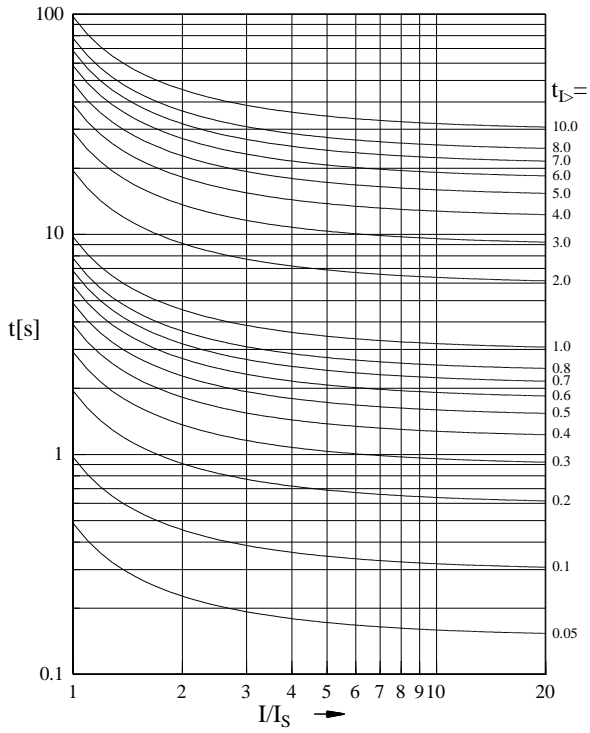

Figure 7.8: RI-Inverse

7.6 Output relays

Contacts: 2 change-over contacts for relay 1 and 2; 1 change-over contact for relay 3-4

Technical data subject to change without notice!

8. Order form

Time overcurrent-/earth fault current relay with thermal replica		MRI3	T				
3-phase current I>, I>>							
Rated current	1 A	I1					
	5 A	I5					
Thermal replica							
Earth current	none		*				
Rated current	1 A		E1				
	5 A		E5				
Directional feature							
in earth path	none			*			
Rated voltage	100 V			R1			
in earth path	230 V			R2			
	400 V			R4			
Housing (12TE)	19"-rack					A	
	Flush mounting					D	
Communication protocol RS485 Pro Open Data; Modbus RTU							* -M

Setting list MRI3-ITE(R)

Project: _____ Job.-no.: _____

Function group: = _____ Location: + _____ Relay code: - _____

Relay functions: _____ Password: _____

Date: _____

Note !

All settings must be checked at site and should the occasion arise, adjusted to the object/item to be protected.

Setting of parameters**System parameter MRI3**

Function	Unit type MRI3-	IT	ITE	ITER	Default setting	Actual setting
L1; L2; L3	$I_{\text{primär}}$ (phase)	X	X	X	SEK	
E	$I_{\text{primär}}$ (earth)		X	X	SEK	
IE>; UE>	$U_{\text{prim}}/U_{\text{sek}}$ (earth)			X	SEK	
	1:1 / 3pha / e-n			X	3pha	
	50 / 60 Hz	X	X	X	50Hz	
	Indication activation	X	X	X	FLSH	
P2/FR	Parameter switch/external triggering for FR	X	X	X	SET1	

Parameter protection

Function		Unit	IT	ITE	ITER	Default settings	Actual settings	
	2 parameter sets		X	X	X	Set 1/Set 2	Set 1	Set 2
I _{B,A}	Base current of the thermal overload protection (low set element)	x I _N	X	X	X	0.40		
K _A	Constant		X	X	X	0.50		
I _{B,A}	Energizing delay (time)for the thermal overload	s	X	X	X	0.04		
I _{B,T}	Base current of the thermal overload protection (high set element)	x I _N	X	X	X	0.40		
k _T	Constant		X	X	X	0.50		
I _{B,T}	Energizing delay (time)for the thermal overload	s	X	X	X	0.04		
τ _C	Time constant (cooling down)	min	X	X	X	0.5		
τ _W	Time constant (warming up)	min	X	X	X	0.5		
I>	Pickup value for phase overcurrent	x I _N	X	X	X	0.20		
CHAR I>	Tripping characteristic for phase overcurrent element		X	X	X	DEFT		
tI>	Trip delay for phase overcurrent element	(s)	X	X	X	0.06		
I>+CHARI>	Reset Modus		X	X	X			
I>>	Pickup value for overcurrent high set element	x I _N	X	X	X	1.00		
tI>>	Trip delay for overcurrent high set element	s	X	X	X	0.06		
1:1/3pha/e-n	Residual voltage measuring				X	3pha		
U _E	Pickup value for residual voltage	V			X	1/2/5		
I _{E>}	Pickup value for earth fault low set element	x I _N		X	X	0.01		
WARN/TRIP	Warning/tripping setting			X	X	TRIP		
CHAR I _E	Tripping characteristic for earth fault overcurrent element			X		DEFT		
tI _{E>}	Trip delay for earth fault overcurrent element	(s)		X	X	0.06		
I _{E>} +CHAR I>	Reset Mode	s		X		0		
I _{E>>}	Pickup value for earth fault high set element	x I _N		X	X	0.01		
tI _{E>>}	Trip delay for earth fault high set element	s		X	X	0.06		
SIN/COS	SIN/COS - setting				X	SIN		
Block/Trip	Block/trip - time	s	X	X		EXIT		
t _{CBFP}	Trip time circuit breaker failure protection	X	X	X	X	EXIT		
RS*	Baud-Rate of serial interface		X	X	X	9600		
RS*	Parity check of serial interface		X	X	X	even		
RS	Slave Address of serial interface		X	X	X	1		

*only Modbus Protocol

Assignment of the blocking function*

Parameter switch	Default setting		Actual setting	
	Set 1	Set 2	Set 1	Set 2
Blocking the protection function PR_B	PR_B	PR_B		
Blocking the trip step TR_B				

Function	Default setting				Actual setting			
	Blocking		No blocking		Blocking		No blocking	
	Set 1	Set 2	Set 1	Set 2	Set 1	Set 2	Set 1	Set 2
Parameter set								
I>			X	X				
I>>	X	X						
IE>			X	X				
IE>>			X	X				
tCBFP			X	X				

Assignment of the output relays

Function	Relay 1		Relay 2		Relay 3		Relay 4	
	Default setting	Actual setting	Default setting	Actual setting	Default setting	Actual setting	Default setting	Actual setting
I _{B,A} alarm			X					
I _{B,A} trip	X							
I _{B,T} alarm			X					
I _{B,T} trip	X							
I> alarm					X			
I> trip	X							
I>> alarm					X			
I>> trip	X							
IE>(V) alarm							X	
IE>(V) trip	X							
IE>>(V) alarm							X	
IE>>(V) trip	X							
IE>(R) alarm							X	
IE>(R) trip	X							
IE>>(R) alarm							X	
IE>>(R) trip	X							
tCBFP trip								

Parameter for the fault recorder

Function		Unit	Default settings	Actual settings
FR	Number of recordings		4	
FR	Saving of the recording at the occurrence		TRIP	
FR	Time prior to trigger impulse	s	0.05	
⊕	Year settings	Year	Y=00	
⊕	Month settings	Month	M=00	
⊕	Day settings	Day	D=00	
⊕	Setting of the hour	Hour	h=00	
⊕	Setting of the minute	Minute	m=00	
⊕	Setting of the second	Second	s=00	

Setting of code jumpers

Code jumper	J1		J2		J3	
	Default setting	Actual setting	Default setting	Actual setting	Default setting	Actual setting
Plugged						
Not plugged	X		No function		X	

Code jumper	Low/High-range for Reset Input		Low/High-range for blockage input	
	Default setting	Actual setting	Default setting	Actual setting
Low=plugged	X		X	
High=not plugged				

This technical manual is valid for the software version: D21-2.06 (MRI3-IT-ITE)
 D30-2.06 (MRI3-ITER) Modbus Protocol
 D71-1.05 (MRI3-IT-M/-ITE-M)
 D80-1.05 (MRI3-ITER-M)

Software version