

1 INTRODUCTION

GAC's **EDG5500** digital governor is designed to regulate engine speed on diesel and gaseous-fueled engines. The EDG system is a suitable replacement for any mechanical governor system that needs flexibility, precision, or accurate control of governed speed. The EDG is designed for industrial engine applications from generator sets, and mechanical drives, to pumps or compressors.

With the use of GAC's Quikset Display, the EDG5500 requires no computer or Internet connection.

- Identical Mounting Hole Pattern to ESD5500E
- Simple LCD User Interface
- Fast Setup with 5 push buttons, no potentiometers
- Lockable Display to Prevent Unauthorized Access
- 2 Fixed Speeds (Rated/Idle) and 1 Variable Speed
- Selectable Isochronous or Droop Governing
- Adjustable Starting Fuel Strategy (Black Smoke Reduction)
- Speed Ramping (Idle to Rated or any Speed Setting & Transient Change)
- Overspeed Sensing
- Magnetic Speed Pickup Input
- Includes Standard GAC AUX Input for Synchronizing and Load Sharing



2 SPECIFICATIONS

PERFORMANCE	
Isochronous Operation	± 0.25 %
Speed Range / Governor	400 Hz - 10 KHz (Mag pickup)
Idle Adjust	Full Range
Droop Range	1 - 5 % regulation
Speed Trim	Programmable 0 - 100 %, (default = 5 %)
INPUT / OUTPUT	
Supply	12-24 V DC Battery Systems (7.0 to 33 V DC)
Polarity	Negative ground (Case isolated)
Power Consumption	70 mA MAX continuous plus actuator current
Speed Sensor Signal	1.0 - 120 V RMS
Actuator	8 - 10 A Continuous
Load Share/Synchronizer Input	0-10 V DC (5 V nominal, reversed, 100 Hz / V)
Reverse Power Protection	Yes
Transient Voltage Protection	60 V

ENVIRONMENTAL	
Ambient Temperature	-40° to 85 °C [-40 to 180 °F]
Relative Humidity	up to 95 %
All Surface Finishes	Fungus Proof and Corrosion Resistant
CE Rated	EN55011, EN50081-2, EN50082-2
PHYSICAL	
Dimension	See Section 3, Installation
Weight	1.8 lbf (820 gf)
Mounting	Any position, Vertical preferred
RELIABILITY	
Vibration	7 g, 20 - 100 Hz
Shock	20 g peak
Testing	100 % Functional testing
COMPLIANCE / STANDARDS	
Agency	CE and RoHS Requirements
Communications	SAE J1939 (Option)

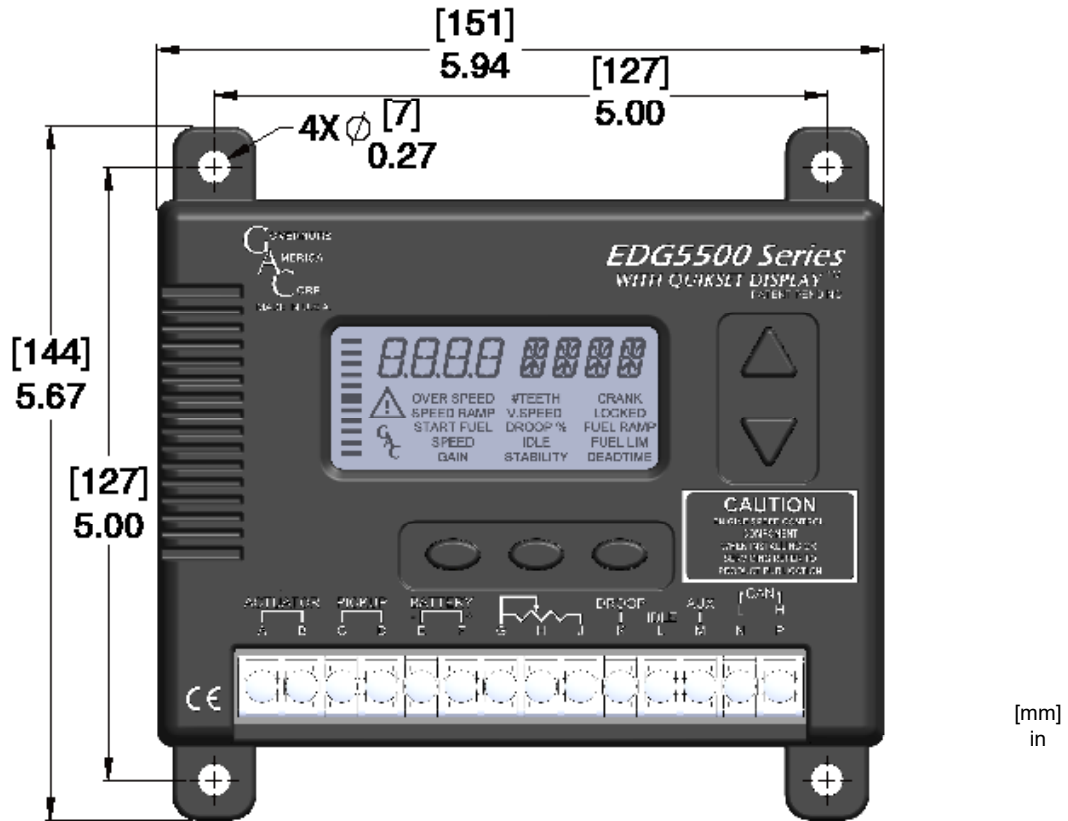

[mm]
in



Vertical orientation allows for the draining of fluids in moist environments.



Mount in a cabinet, engine enclosure, or sealed metal box.



Avoid Extreme Heat



An overspeed shutdown device, independent of the governor system, must be provided to prevent loss of engine control which may cause personal injury or equipment damage. Do not rely exclusively on the governor system electric actuator to prevent overspeed.

A secondary shutoff device, such as a fuel solenoid must be used.

4 WIRING

Basic and optional wiring are detailed in this section. Read this entire Installation guide before wiring any part of this speed control.

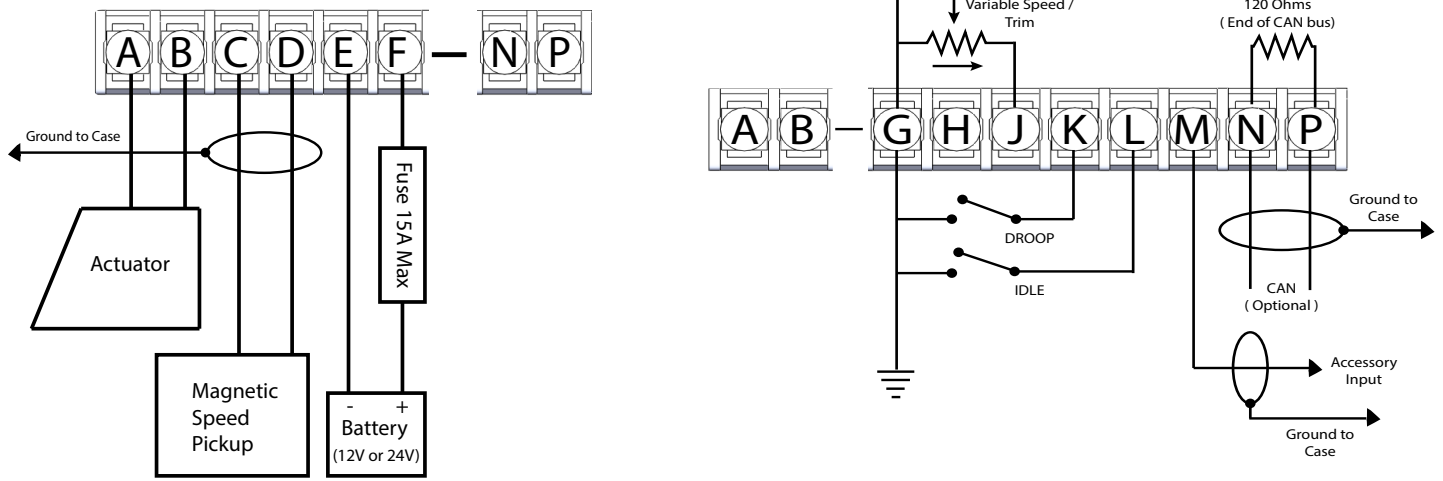

If the EDG5500 detects no input from the magnetic pickup, the EDG will set the actuator to 0V and set the speed to 0 RPM. After the EDG has detected loss of magnetic pickup, the display will flash the RPM and the Warning Indicator. Parameters will be unchangeable.

PIN 3 MAGNETIC SPEED PICKUP

- Wires must be twisted and/or shielded for their entire length (14 turns per foot)
- Gap between speed sensor and gear teeth should not be smaller than 0.02 in. (.51 mm)
- Speed sensor voltage should be at least 1 V AC RMS during crank

TERMINAL	DEFINITION	GAUGE	NOTES
A	Actuator (+)	#16	Not polarity dependent
B	Actuator (-)	#16	
C	Magnetic Pickup (+)	#20	Twist wires 14 turns per foot
D	Mag Pickup Ground	#20	
E	Battery (-)	#16	
F	Battery (+)	#16	A 15 amp fuse must be installed in the positive battery lead to protect against any overload or short circuit
G	Ground Signal	#16	Variable speed/trim input & switches
H	Not Used		
J	Variable Speed Input	#20	Use 5K Ω resistive potentiometer
K	Droop Select	#16	Active when connected to Term. G
L	Idle Select	#16	Active when connected to Term. G
M	Aux Input	#20	Load sharing / synchronizing, 5V nominal (0-10 V), reverse ramp
N	CAN L	#20	Twist Wires 14 turns per foot.
P	CAN H	#20	

RECOMMENDATIONS

1. Shielded cable should be used for all external connections to the EDG control.
2. One end of each shield, including the speed sensor shield, should be grounded to a single point on the EDG case.

5 DISPLAY & CONTROLS

PARAMETER VALUE

Displays the value of a selected parameter or live running parameter. This area will blink if a system shutdown and restart is required.



THROTTLE, DELTA SPEED GRAPH, & CURRENT

Toggle between the 3 views:

Tap UP or DOWN

OVERSPEED

OVERSPEED will blink when the unit is in over-speed. (Cycle power to restart)

OVER SPEED

QUIKSET MENU

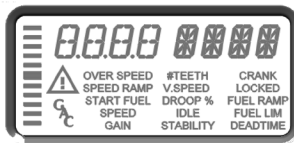

The menu displays one row of parameters at a time.

PARAMETER UNITS

Displays the units for the parameter (e.g. RPM)



ADJUST PARAMETER VALUE

Parameter Adjust UP



Parameter Adjust DOWN

To increase parameter one increment value:

HOLD and TAP or

Rapidly Increment value:

HOLD and HOLD or

Lock Display:

HOLD and for 2 seconds

Unlock Display:

HOLD and for 10 seconds

COLUMN SELECT BUTTONS

1 2 3



To change parameters displayed:

Tap any

To view a parameter value in a selected row:

Hold

For: SPEED Hold: Button 1

For: IDLE Hold: Button 2

For: FUEL LIM Hold: Button 3



LOSS OF MAGNETIC SPEED PICKUP / OVERCURRENT



If the EDG detects loss of magnetic pickup, the display will flash the RPM and Warning Indicator. Parameters will be unchangeable.

ADJUSTABLE QUIKSET PARAMETERS

OVERSPEED	#TEETH	CRANK
Range: 500 - 9999 RPM Default: 2220 RPM	Range: 50 - 255 Default: 120	Range: 0 - 9999 RPM Default: 400 RPM
RPM to automatically shutoff the actuator	Number of teeth on flywheel	RPM which EDG switches to starting fuel ramp
SPEED RAMP	V.SPEED	LOCKED
Range: 0 - 9999 Default: 400	Range: 0 - 9999 RPM Default: 5 RPM	Range: OFF, ON Default: OFF
Rate at which speed changes from idle to set speed and back, or rate change in variable speed mode.	Maximum speed change allowed from trim input	Indicates if EDG will lock after 5 minutes of non-use To unlock, press both UP and DOWN simultaneously for 10 seconds
START FUEL	DROOP%	FUEL RAMP
Range: 0 - 100% Default: 100%	Range: 0 - 25.0% Default: 5.0%	Range: 1 - 100% / s Default: 2 %
Initial actuator position at start of cranking	Droop to apply under maximum load (based on current of actuator)	% / s to apply fuel as engine starts to idle
SPEED	IDLE	FUEL LIM
Range: 0 - 9999 RPM Default: 1500 RPM	Range: 0 - 9999 RPM Default: 900 RPM	Range: 0 - 100% Default: 99 %
Operating speed of engine	Speed of engine when IDLE input is closed	Maximum actuator percentage allowed
GAIN	STABILITY	DEADTIME
Range: 1 - 100, 100 = Max Gain Default: 20	Range: 1 - 100, 100 = fastest response Default: 36	Range: 0 - 100 Default: 21
Proportional (P) set point of the PID control at operating SPEED and IDLE	Integral (I) set point of the PID control	Derivative (D) set point of the PID control

6 PRE-START SET-UP & QUICKSET PARAMETERS

Set the following parameters before starting the engine:

- #TEETH** Input the Number of Teeth on the Flywheel. This cannot be changed while engine is running.
- CRANK** Input the Crank Termination (RPM)
- SPEED** Input the Fixed Speed of the Engine (RPM)

7 ADJUSTING FOR STABILITY

Once the engine is running at operating speed and at no load, the following governor performance adjustments can be made to increase engine stability.

The EDG5500 is equipped with two separate gains, one for rated speed, the other for idle speed. Both are set using the GAIN setting on the Quikset menu.

GAIN TYPE		GAIN ADJUSTMENT PROCEDURE
RATED SPEED	1.	Selected by default. (Value will remain when switching between Idle and Rated Gain.)
IDLE SPEED	1. 2. 3.	1. Connect the idle input to ground. 2. Change GAIN value. 3. Disconnect Idle input from ground to switch back to Rated.

STABILITY PARAMETER		ADJUSTMENT PROCEDURE
GAIN	1. 2. 3. 4.	1. Increase this parameter until instability develops. 2. Gradually decrease this parameter until stability returns. 3. Decrease this parameter one increment further to ensure stable performance. 4. If instability persists, adjust the next parameter.
STABILITY	1. 2.	1. Follow the same adjustment procedure as the GAIN parameter. 2. If instability persists, adjust the next parameter.
DEADTIME	1.	1. Follow the same adjustment procedure as the GAIN parameter.

NOTE Normally, adjustments made at no load achieve satisfactory performance. If further performance improvements are required, see to Section 9, Advanced and Special Parameters and Section 10, System Troubleshooting.

8 FEATURES

TRIM or VARIABLE SPEED OPERATION

		SPECIAL MENU PARAMETER	QUIKSET MENU PARAMETERS	
MODE	DESCRIPTION	VSPD	SPEED	V. SPEED
Trim (Default)	Performs finer adjustments (e.g. generator frequency)	OFF	Application Rated Speed (e.g., 1500 RPM)	Speed Trim Percentage (e.g., 5% = ±90RPM)
Variable Speed	Operates over a larger RPM range	ON	Minimum speed when potentiometer is at lowest resistance (e.g., 1000 RPM)	Maximum speed when potentiometer is at highest resistance (e.g., 2000 RPM)

SPEED DROOP OPERATION

Droop replicates a mechanical governor's response to load change. Using Droop the engine speed will decrease as engine load increases. DROOP% (Quikset Menu) is based on the change in current in the actuator (see Section 6, Special Menu Parameters) from no load to full load. Before adjusting DROOP%, the optional external selector switch must be in DROOP position.

MODE	D SW	SPEED
SPEED with Auto Offset	ON	Controller will run at SPEED (Quikset Menu) with an offset determined by the DROOP%
Droop Speed	OFF	Controller will run to DSPD (Special Menu). A manual offset is required for operation

IDLE SPEED

The optional external switch must be tied to terminal G. Pressure switch may also be used as a method of enabling.

ACCESSORY INPUT

The Aux terminal accepts signals from auto synchronizers, load sharing units, and other GAC accessories.



9 ADVANCED AND SPECIAL PARAMETERS MENU

Advanced Menu Parameters will further adjust engine stability. Special Parameters enables additional options.

Display Special Menu Parameters:

Hold ALL 3  until AUX appears in display

Adjust Parameters:

Increase Parameter 
Decrease Parameter 

Selecting Parameters:

Previous Parameter Next Parameter

Return to Quikset Menu: Hold ALL 3  for 2 seconds

SPECIAL MENU PARAMETERS

PARAMETER	DEFINITION	RANGE	DEFAULT
AUX	Auxiliary Input Enable	Off, On	Off
AVE	On = Averages four pulse samples from the Mag-Pickup for more accurate response Off = Calculates speed from pulses tem update	Off, On	Off
VSPD	Variable Speed or Trim Select (On=Variable Speed, Off=Trim)	Off, On	Off
SOFT	Soft Coupling - Dampening of system (slow down response)	Off, On	Off
LEAD	Lead Circuit - Response increase	Off, On	Off
D SW	Sets the droop mode On=Auto Offset Off = Manual Offset	Off, On	On
DITH	Adds white noise to actuator or throttle body prevent sticking in the fuel rack.(%)	0 - 10	0
DRNG	System current to the actuator that represents full load. Units in (A)	0.0 - 10.0	3.9
DSPD	Droop offset when DSW is set to Off (RPM)	0 - 9999	1500
OVRC	Overcurrent - Turns off actuator if specified current value is exceeded. Units in (A)	0 - 12	11.7

ADVANCED MENU PARAMETERS

PARAMETER	DEFINITION	RANGE	DEFAULT
RATE	The time (mS) between calls to the PID control loop.	4 - 250 mS	4
FLTR	Number of speed samples in frequency calculation. Filter is active when soft coupling (SOFT) is set to ON. Lower numbers filter high frequency noise.	1 - 62 samples	40
GMUL	If the GAIN parameter is at maximum and more GAIN is required, increase GMUL. GAIN will be more responsive. If small changes in the GAIN parameter are over responsive, decrease GMUL.	1 - 20	17
SMUL	If the STABILITY parameter is at maximum and more STABILITY is required, increase SMUL. STABILITY will be more responsive. If small changes in STABILITY parameter are over responsive, decrease SMUL.	1 - 20	17
DMUL	If DEADTIME value is at maximum and more DEADTIME is required, increase DMUL. DEADTIME will be more responsive. If small changes in DEADTIME parameter are over responsive, decrease DMUL.	1 - 20	12



Multiplier Changes can make drastic changes. Changing a multiplier (e.g. GMUL) will affect the corresponding Quikset parameter (e.g. GAIN) in two ways:

1. If the multiplier is decreased by 1, corresponding Quikset value will double.
2. If the multiplier is increased by 1, corresponding Quikset value will halve.

The engine will maintain current operation while adjusting parameters. (i.e. NO CHANGES) Since the scaling will be made to the Gain, Stability, and Derivative parameters automatically, go back and readjust these parameters to the desired levels.

10 SYSTEM TROUBLESHOOTING

SYSTEM INOPERATIVE

If the engine governing system does not function, the fault may be determined by performing the voltage tests described in Steps 1 through 3. Positive (+) and negative (-) refer to meter polarity. Should normal values be indicated during troubleshooting steps, then the fault may be with the actuator or the wiring to the actuator. Tests are performed with battery power on and the engine off, except where noted. See your actuator publication for the testing procedure for that actuator.

STEP	WIRES	NORMAL READING	PROBABLE CAUSE OF ABNORMAL READING
1	F(+) & E(-)	Battery Supply Voltage (12 or 24 V DC)	<ol style="list-style-type: none"> DC battery power not connected. Check for blown fuse Low battery voltage Wiring error
2	C & D	1.0 V AC RMS min. While Cranking	<ol style="list-style-type: none"> Gap between speed sensor and gear teeth too great Improper or defective wiring to the speed sensor Resistance between D and C should be 130 to 1200 Ω. See specific mag pickup data for resistance. Likely a defective speed sensor.
3	F(+) & A(-)	1.0 - 2.0 V DC While Cranking	<ol style="list-style-type: none"> SPEED or IDLE parameter set incorrectly CRANK or START FUEL set incorrectly Short/open in actuator wiring Defective speed control Defective actuator, see your actuators troubleshooting information.

INSTABILITY

INSTABILITY	SYMPTOM	PROBABLE CAUSE OF ABNORMAL READING
Fast Periodic	The engine seems to jitter with a 3Hz or faster irregularity of speed. (Not as moderate)	<ol style="list-style-type: none"> Make sure LEAD Special parameter is set to "OFF". Readjust the GAIN and STABILITY for optimum control. In extreme cases, decrease the DEADTIME parameter.
Slow Periodic	Speed irregularity below 3 Hz. (Sometimes severe)	<ol style="list-style-type: none"> Verify the SOFT (soft coupling) Special Menu parameter is disabled. Decrease the update rate of the controller by decreasing the RATE Advanced parameter. (Each time RATE is changed, GAIN, STABILITY, and DEADTIME must be re-adjusted.) Check fuel system linkage during engine operation for: <ol style="list-style-type: none"> binding high friction poor linkage Dead Time Parameter set too high.
Non-Periodic	Erratic Engine Behavior	<ol style="list-style-type: none"> Increasing the GAIN should reduce the instability but not totally correct it. If this is the case, there is most likely a problem with the engine itself. Check for: <ol style="list-style-type: none"> engine mis-firings an erratic fuel system load changes on the generator set voltage regulator.

DISPLAY ACCESS - LOCK / UNLOCK

To unlock the display, press and hold the UP and DOWN arrows simultaneously for 10 seconds

To lock the display, press and hold the UP and DOWN arrows simultaneously for 2 seconds.



If unsuccessful in solving instability, contact GAC for assistance.

GAC@governors-america.com or call: 413-233-1888

UNSATISFACTORY PERFORMANCE

SYMPTOM	NORMAL READING	PROBABLE CAUSE OF ABNORMAL READING
Engine Over Speeds	1. Do Not Crank. Apply DC power to the governor system.	1. If the actuator is at minimum fuel position and there exists an erroneous position signal, then check speed sensor.
	2. Manually hold the engine at the desired running speed. Measure the DC voltage between Terminals A(-) & F(+) on the speed control unit.	1. If the voltage reading is 1.0 to 2.0 V DC: a. SPEED parameter set above desired speed b. Defective speed control unit 2. If voltage reading is > 2.0 V DC then check for: a. actuator binding b. linkage binding 3. If the voltage reading is below 1.0 V DC: a. Defective speed control unit
	3. Check #TEETH parameter.	1. Incorrect tooth count entered.
Over Speed shuts down engine after running speed is reached	1. Examine the SPEED and OVER SPEED operating parameters for the engine	1. SPEED parameter set too high. 2. OVER SPEED set too close to SPEED. 3. Check SPEED RAMP parameter. 4. Actuator or linkage binding. 5. Speed Control unit defective. 6. Gain too low.
Over Speed shuts down engine before running speed is reached	1. Check resistance between Terminals C&D. Should be 130 to 1200 Ω. See specific Magnetic Pick-up data for resistance.	1. OVER SPEED set too low 2. If the speed sensor signal is erroneous, then check the wiring.
Actuator does not energize fully	1. Measure the voltage at the battery while cranking.	1. If the voltage is less than: a. 7 V for a 12 V system, or b. 14 V for a 24 V system, Then: 1. Check wiring 2. Check circuit protection/relay 3. Check charging system 4. Check battery
	2. Momentarily connect Terminals B & F. The actuator should move to the full fuel position.	1. Actuator or battery wiring in error 2. Actuator or linkage binding 3. Defective actuator 4. Fuse open. Check for short in actuator or harness. 5. Check START FUEL and CRANK
Engine remains below desired governed speed	1. Measure the actuator output, Terminals A & B, while running under governor control.	1. If voltage measurement is within 2 V DC of the battery supply voltage level, then fuel control is restricted from reaching full fuel position, possibly due to mechanical governor, carburetor spring, or linkage interference. 2. Check SPEED, IDLE, GAIN, START FUEL, and CRANK