

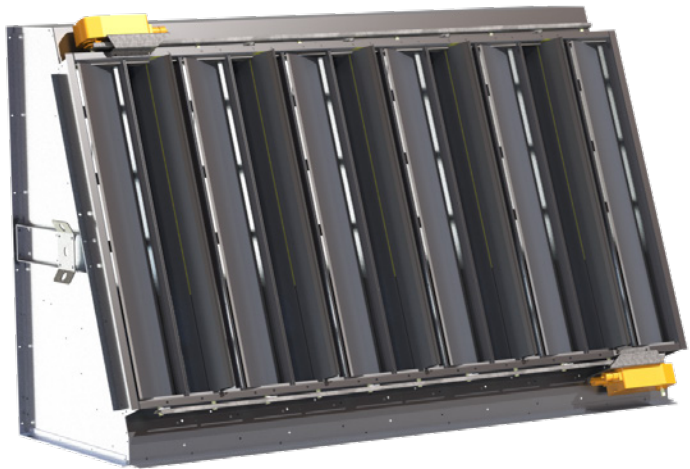

**Blender** INC.  
**Products**



## **Channel Blender**

Reduce Air Stratification  
& AHU Footprint

# Contents

About **02**

---

Features & Options **07**

---

Product **11**

---

Agency Certifications **18**

---

About Blender Products **19**

---

## About Channel Blender

### Performance Advantages

- ▶ Reduce AHU footprint
- ▶ Eliminate nuisance freeze stat alarms
- ▶ Protection against frozen coils
- ▶ Improve Indoor Air Quality
- ▶ Enhance airflow uniformity to other AHU sections
- ▶ Reduce operating costs by extending economizer durations
- ▶ Enhance ventilation reliability
- ▶ Reduce sensor error
- ▶ Maintain damper authority

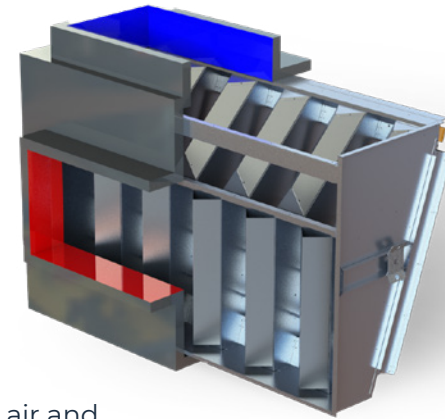

Only proper mixing of return air and outdoor air can directly address the root cause of air stratification inside an air handling unit (AHU). Contrary to common practice, no orientation of the OA and RA dampers in the walls of a mixing box or economizer section can effectively address this issue. The Channel Blender is the most effective mixing solution to combat air stratification and provides building operators the flexibility to maintain healthy ventilation rates in a variety of operating conditions.

The Channel Blender is engineered to increase the coldest temperature in the plenum to eliminate freeze stat trips, protect coils, and provide a more uniform flow pattern to other sections of the AHU. The Channel Blender contains both OA and RA control dampers that are integrated into a frame that channels OA and RA into adjacent paths that are mixed immediately downstream of the control dampers. This clever solution provides effective mixing without the additional footprint required from traditional mixing solutions.

## Air Stratification

Maintaining proper ventilation rates provides a myriad of benefits including reducing the risk from infectious aerosols. If the outdoor airstream is not well-mixed, significant air stratification inside an AHU can lead to increased operating costs and poor indoor air quality.

- ▶ No orientation of the OA & RA dampers can effectively address air stratification.
- ▶ Complete mixing of return and outdoor air is essential to proper coil operation (ASHRAE, HVAC System and Equipment).
- ▶ Traditional mixing boxes fail to provide effective mixing.

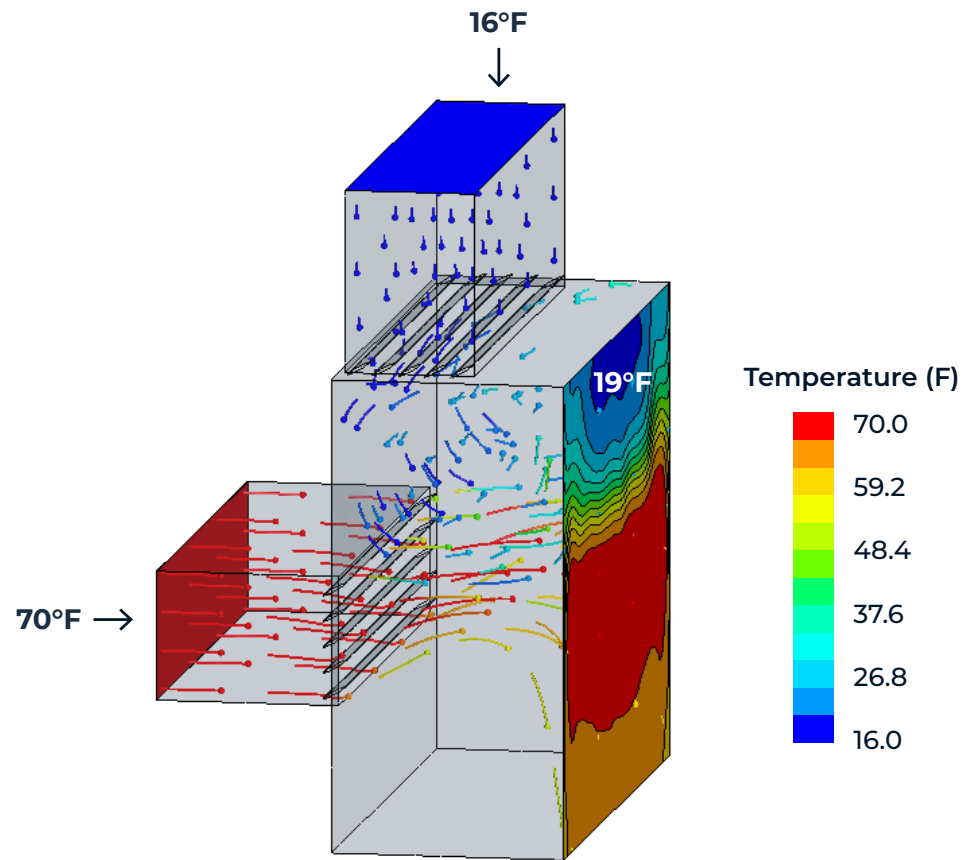

Temperature Stratification  
inside Mixing Box of AHU

# How It Works

1.

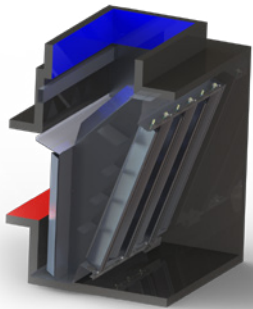

OA & RA enters the mixing box through designated openings. The Channel Blender is installed to align to these openings. Each airstream flows into the corresponding compartment in the Channel Blender.

2.

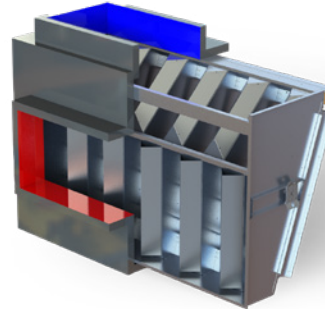

OA & RA flow into adjacent channels, so there are alternating slices of OA & RA flowing towards the dampers. Turning vanes in the channels distribute air evenly across the Channel Blender. Channel walls are insulated to prevent condensation and sealed to prevent OA leakage into the AHU.

3.

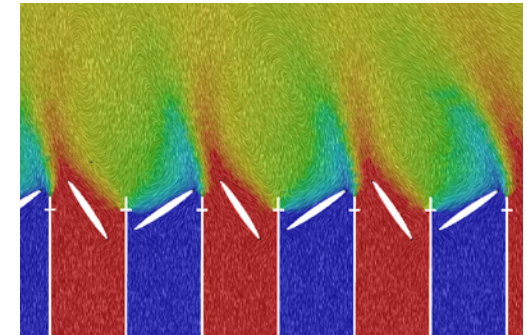

The dampers are used to promote mixing zones immediately downstream of the dampers and this provides a smaller temperature gradient approximately 8" – 12" downstream of the mixer.

## The Result

The result is an economizing mixing box that provides the airflow control for ventilation & economizing while eliminating freeze stat trips and reducing air stratification to downstream components.

AHU-1: Supply Flow 44,000 CFM - OA Flow 11,000 CFM @ 16°F

### AHU-1 (No Mixer)

- ▶  $T_{mix} = 55^{\circ}\text{F}$
- ▶  $T_{min} = 19^{\circ}\text{F}$
- ▶  $\Delta P: .15''\text{wc}$

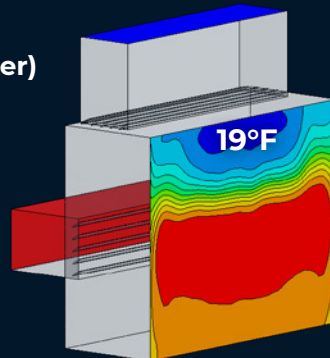

### AHU-1 (w/ Channel Blender)

- ▶ QTY. (1) CB installed at no additional AHU length
- ▶  $T_{mix} = 55^{\circ}\text{F}$
- ▶  $T_{min} = 46^{\circ}\text{F}$
- ▶  $\Delta P: .41''\text{wc}$   
(0.26" increase)

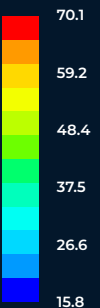
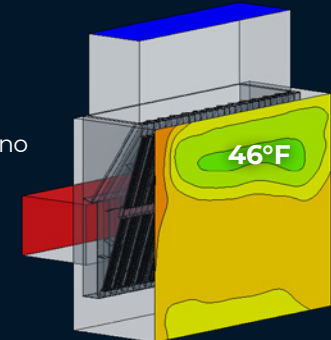

# Optimize AHU Performance

The Channel Blender improves airflow uniformity for downstream components (e.g., coils, filters) while reducing AHU tunnel length and reducing air stratification. Consider a traditional mixing box with a plenum that is 140" wide and 110" high. Total supply airflow is 44,000 CFM with 25% OA. Under summer conditions:

- ▶ OA: 90°F DB/75% RH
- ▶ RA: 70°F/60% RH
- ▶ Mixed Air Temperature of 75°F.
- ▶ The contour plots demonstrate the Channel Blenders ability to promote airflow uniformity and should improve coil performance
- ▶ Reduce the variability of moisture loading to CW coil
- ▶ Optimize humidity control in downstream spaces

	H2O Mole Fraction RMS (%)	Relative Humidity RMS (%)	Velocity RMS (%)
No Mixer	31.7	8.5	37.0
Chanel Blender	8.6	3.5	19.5

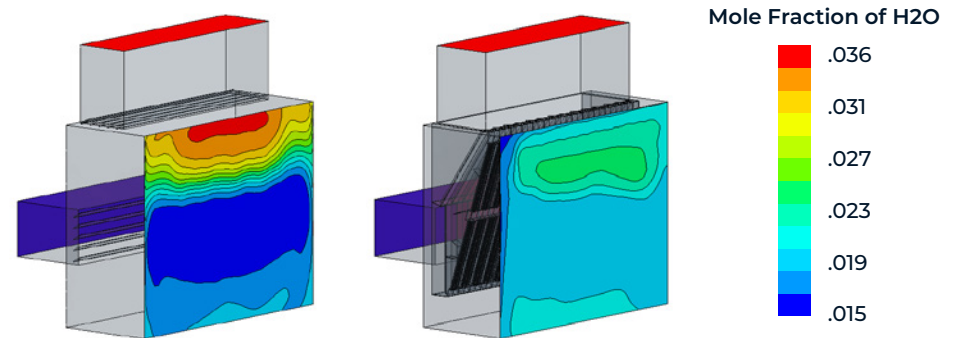

Contour Plots of the Water Mole Fraction for No Mixer and Channel Blender Cases

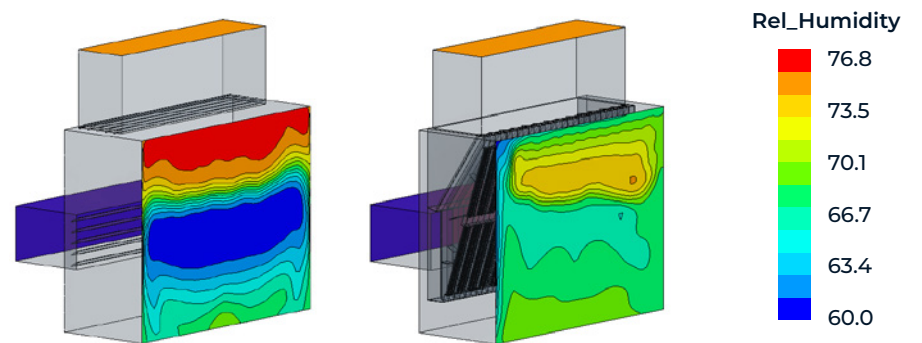

Contour Plots of the Relative Humidity for No Mixer and Channel Blender Cases



## Construction

- ▶ Flange provided around Channel Blender frame to allow easy mounting to air handling plenum ceiling, walls, or floor.
- ▶ Nearly all aluminum construction reduces corrosion concerns.
- ▶ Channel walls are insulated double wall construction to eliminate condensation.
- ▶ Damper options include both insulated and non-insulated double-wall aluminum extruded blades.
- ▶ Damper actuators and linkage located on downstream side for service access.



## Features and Options

The Channel Blender contains several unique features and is designed to fit almost any mixing box or economizer section. Many of these features allow end users and AHU design engineers to configure the product to meet all their air handling unit requirements.

### Damper Blades:

The damper blades are integrated into the Channel Blender construction and seal against “damper stops” built into the end of each channel wall. The damper blades and channel construction are designed to provide a low leakage (< 3 cfm/sq. ft @ 1” wc) damper assembly. The dampers seen on the right are available options.

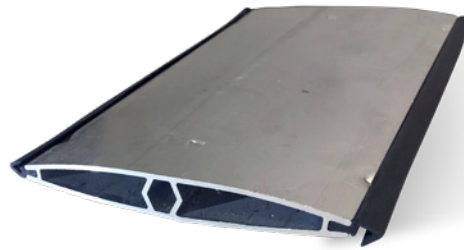

#### 1. Control Damper:

This is a double-wall aluminum extrusion with neoprene blade edge seals on opposite sides of the blade to seal against the damper stops. Blade size: 6” width.

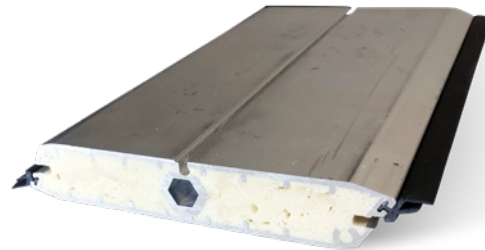

#### 2. Insulated Damper:

Our most thermally efficient damper with insulated extruded aluminum blades designed for extreme cold weather applications. The blade is designed with a thermal break to eliminate thermal transfer and reduces the potential for condensation. Blade size: 6” width.





### Actuators:

The Channel Blender is provided with 1/2" dia. jackshafts and brackets for mounting damper actuators to modulate the OA & RA damper blades. The Channel Blender can be ordered with or without damper actuators mounted at the factory. The mounting system is only compatible with Belimo (ABF24) or Ruskin (RUS-L24) style actuators. Other actuators that do not have the same body style will not fit properly. Please consult a Blender Products application engineer for additional information.

1. Damper actuator sizing:  
10 in-lbs per sq. ft of damper area.

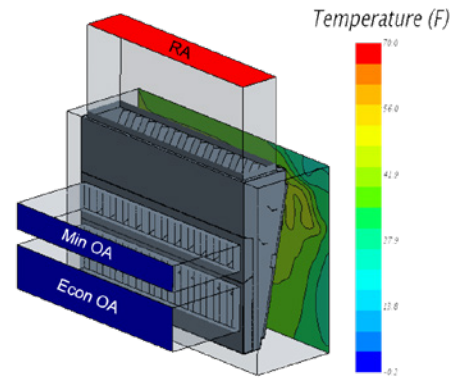

### Dedicated Minimum OA Duct:

AHUs that require a minimum OA flow measurement typically require a separate OA damper bank and dedicated minimum OA duct connected to these dampers. An airflow measurement station is typically part of the minimum OA duct. You can specify a Minimum OA sectioning of the OA channels on the Channel Blender.



### Split Channel Blender Orientation:

In cases when the AHU plenum width exceeds 144", multiple Channel Blenders can be used in the same tunnel. In addition, if smaller Channel Blenders are required to support handling and installation logistics, please consult a Blender Products representative.

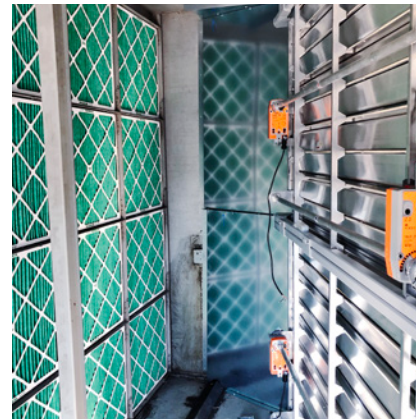

### Knockdown Construction:

In isolated retrofit applications, the Channel Blender can be assembled inside an existing mixing box. Please contact a Blender Products representative to review installation considerations and assembly requirements in the field.

# Channel Blender Model Number

**CB   -140   -01   -37   -21   -150   -0   CD   CD**

Description	Code
Standard	CB
Custom	CBC
Knockdown	CBK
Split (identical) units	2XCB

Blade Length	Code
1 = Single Damper Bank	1XX
2 = Double Damper Bank	2XX
XX = Blade Length	Integer (in)

Orientation	Code
OA Top/RA Back	01
OA Back/RA Top	02
OA Bottom/RA Back	03
OA R Side/RA Back R Side	04
OA Back R Side/RA R Side	05
OA Back R Side/RA L Side	06
OA L Side/RA Back L Side	07
OA Back L Side/RA L Side	08
OA Bottom Back/RA Top Back	09
OA Top Back/RA Bottom Back	10
OA L Side/RA R Side	11
OA R Side/RA L Side	12
OA Top/RA Bottom	13
OA Bottom/RA Top	14
OA R Back/RA L Back	15
OA L Back/RA R Back	16
OA L Side/RA Back/EA R Side	17
OA R Side/RA Back/EA L Side	18

Code	OA Damper Type
CD	Control Damper
TD	Insulated Damper

Code	RA Damper Type
CD	Control Damper
TD	Insulated Damper

Code	Acuator Option
Integer	Acuator Quantity

Code	RA Damper Type
00 X	Percentage Outside Air
XX 0	No Dedicated Min. OA Duct
XX 1	Dedicated Min. OA Duct

Code	Total Number of Channels
Integer	Channel Quantity

Code	Depth
Integer (in)	Channel Blender Depth

Channel Blender Orientation Codes

01. OA Top/RA Back

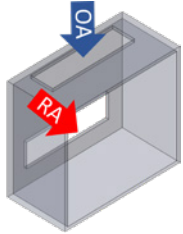

02. OA Back/RA Top

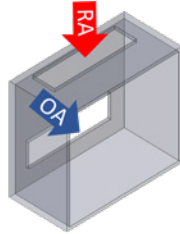

03. OA Bottom/RA Back

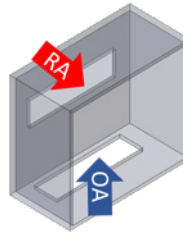

04. OA Back/RA Bottom

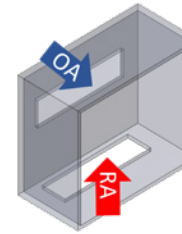

05. OA R Side/RA Back

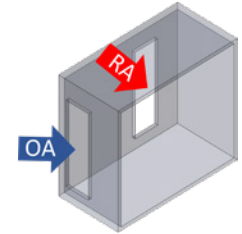

06. OA Back/RA R Side

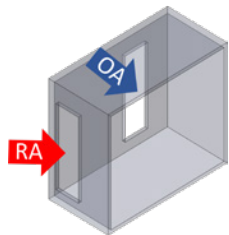

07. OA L Side/RA Back

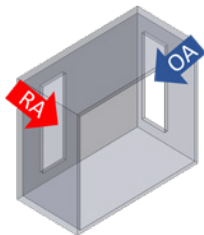

08. OA Back/RA L Side

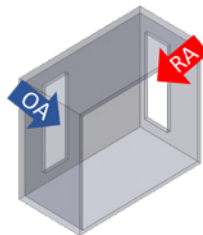

09. OA Bottom Back/RA Top Back

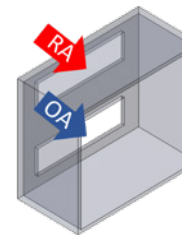

10. OA Top Back/RA Bottom Back

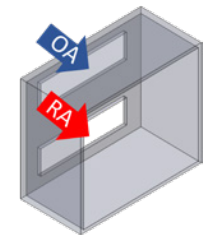

11. OA L Side/RA R Side

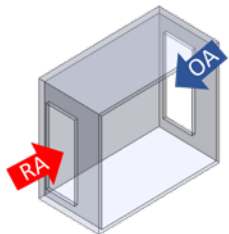

12. OA R Side/RA L Side

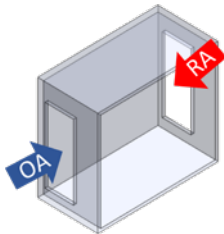

13. OA Top/RA Bottom

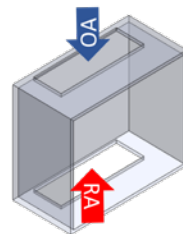

14. OA Bottom/RA Top

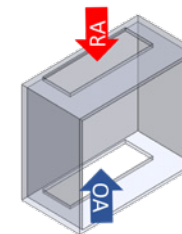

15. OA R Back/RA L Back

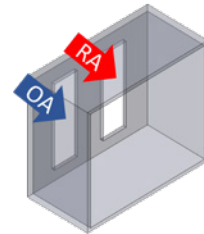

16. OA L Back/RA R Back

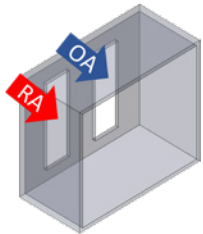

17. OA R Side/RA Back/EA L Side

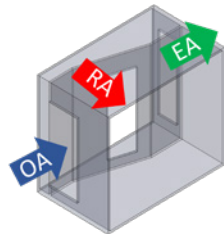

18. OA L Side/RA Back/EA R Side

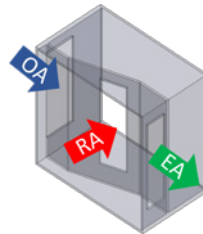

## Product Selection

The Channel Blender is designed to fit into almost any mixing box arrangement. To make Channel Blender selection, the following inputs are required:

- ▶ Supply Air (CFM)
- ▶ Minimum OA Flow (CFM)
- ▶ Inside Plenum dimensions (H x W)
- ▶ Orientation of OA and RA inlets to the air handling unit (Reference information in page above)

The Channel Blender can be configured for most AHU applications with an on-line selection tool that can be found at [www.blenderproducts.com](http://www.blenderproducts.com).

Please visit one of our local manufacturing representatives if you have questions or need additional information. A list of Blender Products representatives can be found at [www.blenderproducts.com](http://www.blenderproducts.com).

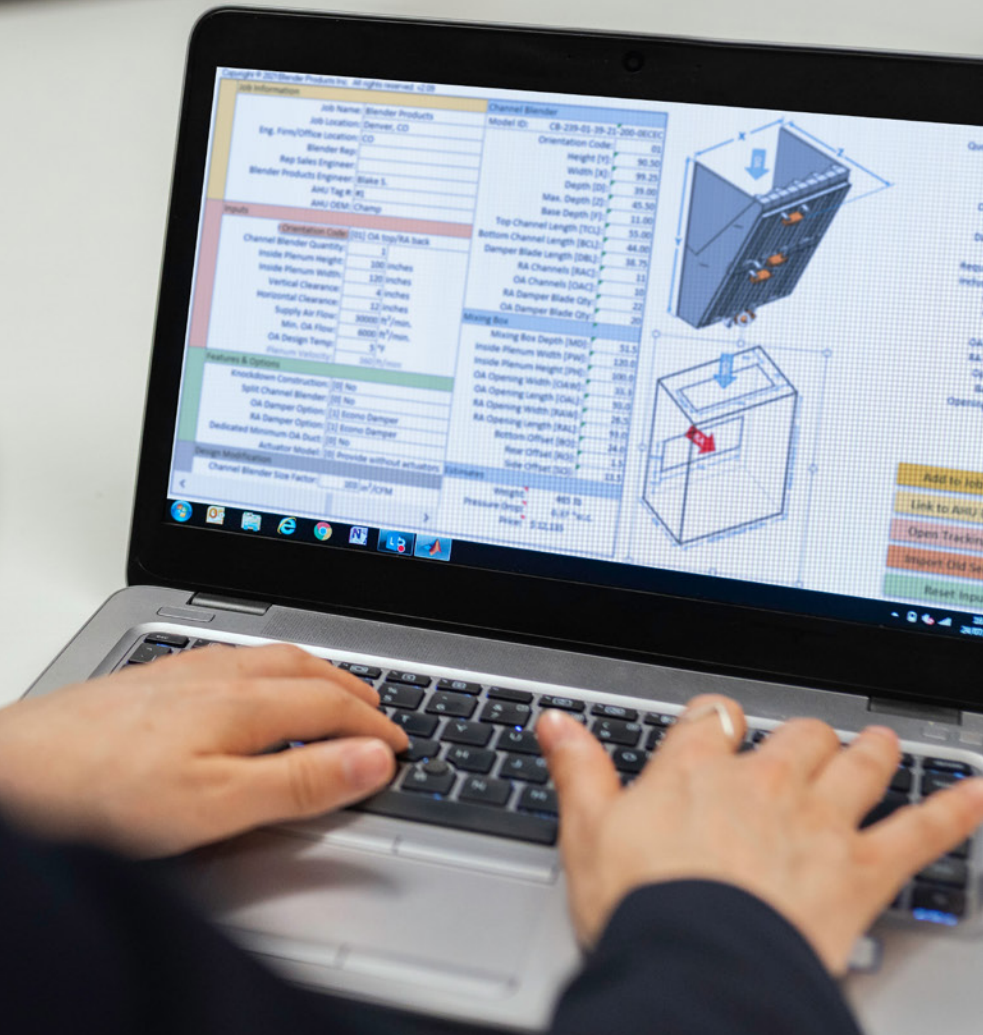

# Product Specification

## MAX. PLENUM VELOCITY

600 FPM

## APPLICATION TEMPERATURE RANGE

-20°F TO 140°F

## MAX. INTERNAL TO EXTERNAL PRESSURE

4"W.G.

## MAX. OA CHANNEL TO RA CHANNEL $\Delta P$

4"W.G.

## DAMPER LEAKAGE ALLOWANCE

3 CFM/FT<sup>2</sup> OF DAMPER  
SURFACE AREA AT A PRESSURE  
DIFFERENTIAL OF 1" W.G.

## DAMPER LEAKAGE CLASS

CLASS 1A

## DAMPER ACTUATOR SIZING

10 IN-LB/FT<sup>2</sup> OF  
DAMPER SURFACE AREA.

## EST. WEIGHT

TYPICAL CHANNEL BLENDER WILL  
WEIGH LESS THAN 4 LBS/FT<sup>3</sup> OR  
APPROXIMATELY 0.17 LB/CFM



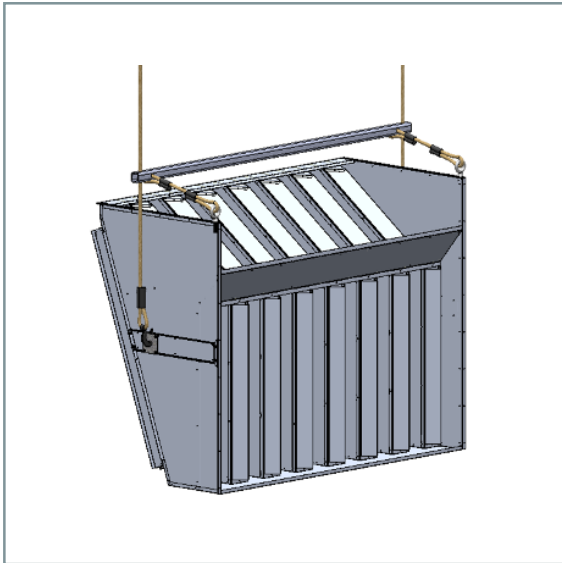
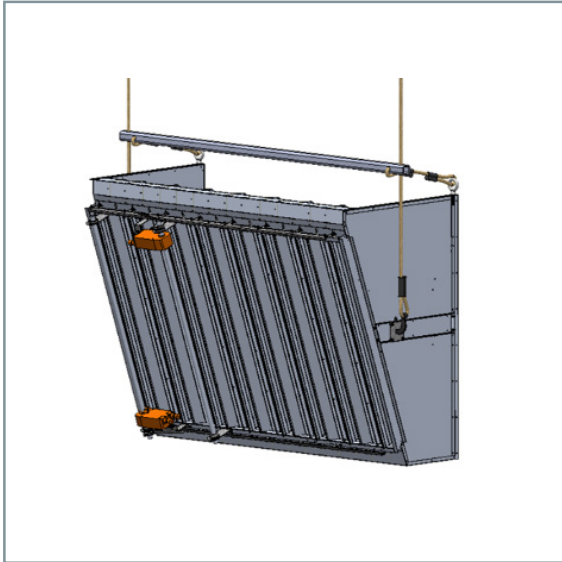

## Product Storage & Handling

The Channel Blender as shipped from the factory is crated and wrapped in plastic to protect from short term exposure to outdoor conditions while in transit. Long term storage should be in a dry location, or shipping crate tarped for longer term outside storage making sure the product is adequately protected from the elements.

The product is provided with four lifting points. Two lifting points on the sides are located approximately at the product's center-of-gravity axis. Additional eyelets can be used as shown to balance and steady the load when lifting. Use these lifting points as shown below to remove the Channel Blender from the shipping crate, transport to a manufacturing location, and/or positioning in a mixing box for mounting. These lifting points can also be used for support as necessary of the product in the mixing box. Do not lift the product by the damper blades, damper frame, or damper linkage.

Channel Blenders with horizontal blades for side entry mixing boxes are designed to sit on the floor of the AHU. There is a base that includes fork lift pockets to lift and move the unit.





## Product Installation

The Channel Blender is designed to be installed in the mixing box to align to OA and RA openings in the mixing box walls according to the selected orientation. The size and location of the openings are provided in the document submittal for each unit.

The Channel Blender is designed to either “hang” from the wall and ceiling of the mixing box, or sit on the floor of the AHU plenum and secure to a wall or walls. Additional details and dimensions for the Channel Blender are provided with the Channel Blender submittal.

Please reference our tech bulletin CB-TB-101 which can be available for download from our website or your local Blender Products representative.

# Channel Blender Damper Control Sequence

For a Channel Blender without a dedicated minimum OA section, the damper control sequence is similar to a standard mixing box or economizer section. The OA damper actuator is provided with the inverse of the signal provided to the RA damper actuator. The exact position of these dampers to provide the correct Min OA flow rate will vary based on the system (e.g., RA fans, duct-work pressure drop, OA hoods) and will need to be determined during commissioning. If the damper banks require multiple actuators for each airstream (RA & OA), all of the actuators for each airstream should receive the same signal. A graphical representation of this control scheme is presented below.

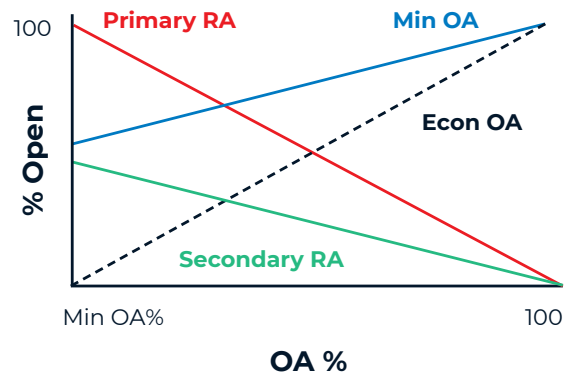
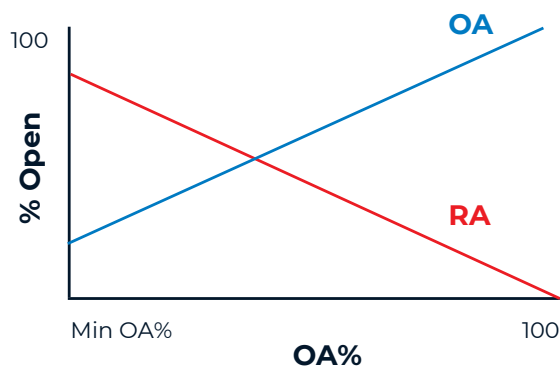

If the Channel Blender includes a dedicated minimum OA section, a control scheme that includes independent control of all four damper banks will be provided. The Channel Blender is designed such that the Min OA damper and Secondary RA dampers are paired together and receive an inverse control signal from one another. The Econ OA and Primary RA dampers are also paired together in a similar way. Channel Blenders with Min OA may have slightly different control sequences if the RA and OA ducts are in different orientations. Always refer to the control sequence provided in the Channel Blender submittal package.

# Extend Economizer Operations

## Financial Payback

The primary benefit of airside economizer systems is the use of outside air to satisfy the building cooling requirements without the use of mechanical cooling, thereby realizing significant energy savings. Unfortunately, economizer operations are frequently abandoned in cold weather climates due to temperature stratification and potential to cause damage to downstream coil sections.

To help demonstrate the impact of temperature stratification and the additional costs building operators incur due to prematurely abandoning economizing operations due to low temperature alarms, consider the standard mixing box configuration to the right.

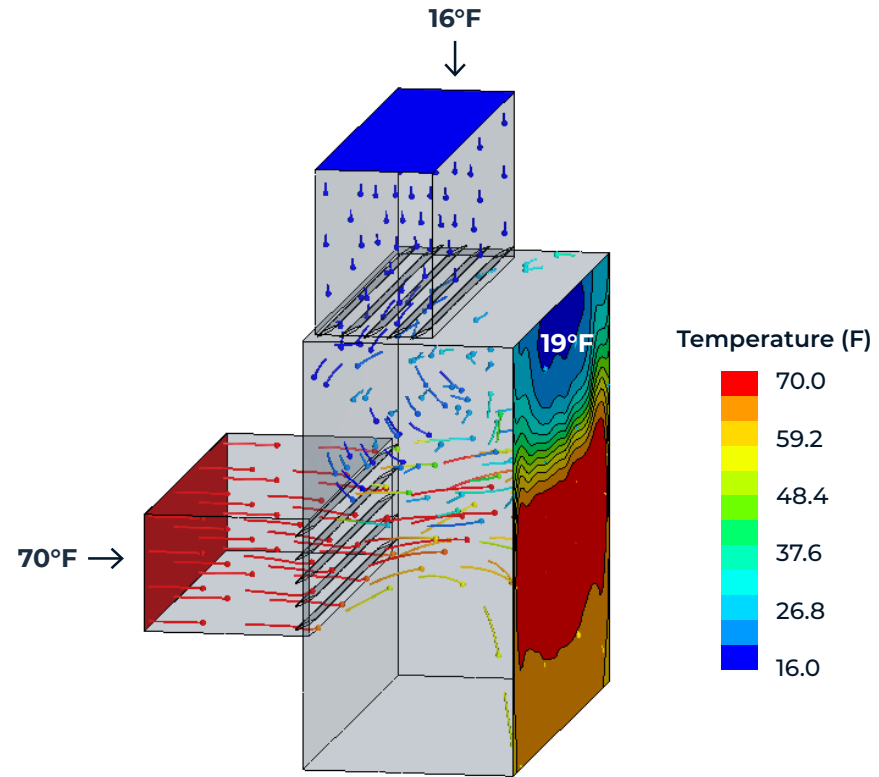

Temperature Stratification Inside Mixing Box of AHU



## Extend Economizer Operations Cont.

An energy analysis was performed in Minneapolis, Denver, and New York City to quantify the number of extended economizing hours the Channel Blender would provide due to the increased mixing and raising the minimum temperature above a freeze stat threshold. **Extending economizer operations when the OA temperatures range between 10°F to 30°F results in significant energy savings.** When considering the equipment cost of the Channel Blender relative to the energy savings potential, simple payback for the equipment installed ranged from 6 months to approximately 5.7 years depending on location. This payback duration is based strictly on energy savings and does not consider the additional benefits of eliminating freeze stat trips and removing the risk of rupturing a coil.

**Extended Economizer Hours for AHU in Denver, CO due to Increased Mixer Performance (SA = 44,000 CFM, OA = 25%)**

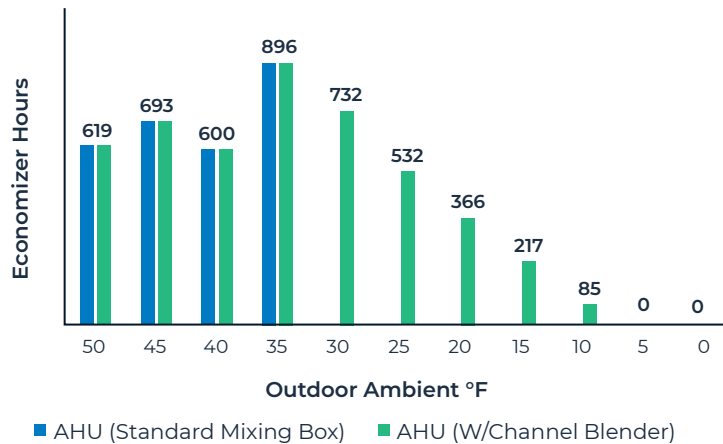

**Estimated Payback Periods for Subject Channel Blender (SA = 44,000 CFM, OA = 25%)**

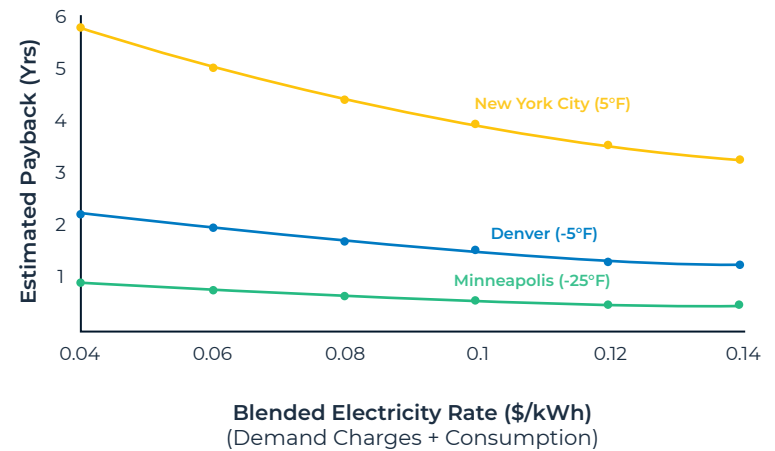





## Agency Certifications

The Channel Blender is a Recognized product. A representative sample of the Channel Blender has been evaluated by UL and meets applicable safety standards. Compliant with UL Standard 1995 "Heating and Cooling Equipment." UL File No: SA44968.

Reach out to a Blender Products representative for additional UL compliance information.



**Blender** INC.  
**Products**

## About Blender Products

Blender Products, Inc. was founded in 1962 with a unique focus on air and gas mixing through the application of static mixing technology. The company's patented products and services have been applied on tens of thousands of processes worldwide.

We are a Denver-based, privately-owned business, and 100% of our manufacturing is completed in the U.S.A. We are engineering-driven, and we exist to serve customers by providing truly valuable products and systems to our customers.

### Contact:

 [blenderproducts.com/channel-blender](https://blenderproducts.com/channel-blender)

 [info@blenderproducts.com](mailto:info@blenderproducts.com)

 5010 Cook St. Denver, CO 80216

 303.295.6111

*Consult Blender Products, INC.'s terms and conditions of sale for warranty information, limitations of liability, and other operating information and restrictions applicable to this product.*