

SM308gb - rev 11/04

## Electromagnetic multidisc clutch E140



We, **WARNER ELECTRIC EUROPE**, 7, rue Champfleu, B.P. 20095, F-49182 St Barthélemy d'Anjou Cedex  
 declare that the clutches made in our factories from St Barthélemy d'Anjou,



and hereafter designated : **E140**

are exclusively designed for incorporation into a machine and to be assembled with other equipments to create a machine. The operation of the product is submitted to the conformity of the complete equipment, following the provisions of the machinery directive 98/37/EC and if electric to the EMC directive 89/336 /EEC.

The conformity of the electric units to the Low Voltage directive 72/23 (modified) is supported by the full respect of the following standards : NFC 79300 and VDE 05808/8.65.

Drawn up in St Barthélemy d'Anjou, July 2002  
 E. PRAT, General Managing Director

## CONTENTS

					
1	Technical specifications	2	3.3	Setting up	3
2	Precautions and restrictions on use	2	4	Maintenance	3
2.1	Restrictions on use	2	4.1	Exchange discs	34.2
2.2	Precautions and safety measures	2	5	Electrical connection	4
3	Installation	3	5.1	Important recommendations	4
3.1	Transport - storage	3	5.2	Supply	4
3.2	Handling	3	6	Lubrication	4
			7	Appendix	5

### 1 Technical specifications

Size		10	20	50	100	200	400	800	1600	3200
Max. speed	min <sup>-1</sup>	3000	3000	3000	3000	3000	2200	2000	1600	1500
Dimension L ±0,5	mm	52	55	60	67	72	96	109	142	157
Weight	Kg	1,1	2,9	3,9	5,9	7,8	15	22	51	67

Table 1

### 2 Precautions and restrictions on use

#### 2.1 Restrictions on use



E140 units are designed to run solely in oil.



Exceeding the maximum rotation speed given in the catalogue invalidates the warranty.



These units are designed for a maximum ambient temperature of 40°C (155°C lining class).



E140 clutches are designed to run with the shaft horizontal. Ask our technical department about other positions

#### 2.2 Precautions and safety measures



During maintenance, ensure that the machine's moving parts are stationary and that there is no risk of accidental start-up. All intervention have to be made by qualified personnel, owning this manual.



Any modification made to the brake without the express authorisation of a representative of Warner Electric, in the same way than any use out of the contractual specifications accepted by "Warner Electric", will result in the warranty being invalidated and Warner Electric will no longer be liable in any way with regard to conformity.



Symbol designating an action that might damage the brake



Symbol designating an action that might be dangerous to human safety



Symbol designating an electrical action that might be dangerous to human safety

### 3 Installation

#### 3.1 Transport / storage

Our clutches and brakes are supplied in packaging guaranteeing a preservation period of 6 months with land or air transport, or after transport by ship to neighbouring continents (without crossing the tropics).

#### 3.2 Handling



Avoid any impacts on the equipment so as not to alter their performance.



Never carry the equipment by the electrical supply cable.

#### 3.2 Setting up

E140 clutches are supplied bored to tolerance H7 and grooved to tolerance P9 in accordance with NFE22175 / DIN6885 / ISO R773 / BS 4235.

The drive flange (529) is generally supplied rough bored and with no fixing holes.

We recommend a tolerance h6 for the shaft and an adjustment H7/f7 for the flange.



**Important:** Do not forget to stop the inductor (101) rotating by means of a fixed part flush in one of the slots.

Check the play between the inductor and this part (see Fig. 1): 0,5 min. in rotation - 1 mm at the bottom of the slot

The part should not cause any stress on the bearings.

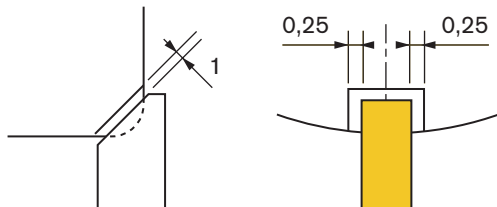

Fig. 1

In case of vibrations, it is strongly recommended to insert a damping elastic slot between the anti-rotation device and the anti-rotation slot and to fix the coil's cable the nearest of it to avoid whipping



In cases where two coaxial shafts are fitted, the recommended setover is 0,05 mm max. The angular misalignment should not exceed 0,1 mm over a length of 100 mm.

- Centre the flange (529) on the receiving part, then fix it with bolts and lock them
- After adjusting the drive key, fit the clutch onto the shaft by locating the slots in the outer discs (303) opposite the arms of the flange (529) and lock it axially on the shaft



Do not forget to tighten the flange (529) fixing bolts to torque and secure them with Loctite 243 or an equivalent type of product.



It is essential when assembling the drive and receiving parts to comply with the length dimension L (see table 1).

### 4 Maintenance

After a running time that varies according to use, it may be necessary to change the inductor bearings. As this is a special assembly, we recommend that it is returned to us for exchange.

#### 4.1 Exchanging discs

The disc set is exchanged when it is too worn to operate the moving armature.

- Remove the unit from the shaft
- Remove the circlips (947), the moving armature (330) and the worn disc set
- Put a new set of discs in place starting with an inner disc (308), followed by an outer disc (303) and so on, alternately, to end with an inner disc (308)
- Replace the moving armature then the circlips
- Refit the unit onto the shaft by locating the slots in the outer discs (303) opposite to the arms of the flange (529)

## 5 Electrical connection

E140 clutches should have a DC electrical supply and are factory fitted with a 500 mm long cable. The polarity has no effect on running.

### 5.1 Important recommendations



All works on the electrical connections have to be made with power off.



Ensure compliance with the nominal supply voltage (inadequate supply causes a reduction in the starting distance and transmissible torque).

The connecting wires should be of sufficient diameter to prevent voltage drops between the source and equipment supplied.

I (A) / L (m)	0 to 10 m	from 10 to 20 m
0 to 3 (A)	1,5 mm <sup>2</sup>	1,5 mm <sup>2</sup>
3 to 6 (A)	1,5 mm <sup>2</sup>	2,5 mm <sup>2</sup>

Tolerance in the supply voltage to the clutch terminals +5% / -10% (NF C 79-300).

### 5.2 Supply

For controlling clutches, we advise the use of Warner Electric supply units.

#### Size 10 to 800:

CBC 400-24  
CBC 450-24  
CBC 140-5

#### Size 1600 à 3200:

CBC 140-5

Warner Electric supply units provide protection for coils and circuits. Where a clutch is used without our supply units, with switching on the DC, it is essential for the coil to be protected against surges by a varistor fitted in parallel.

## 6 Lubrication



The disc lubricating oil should not exceed 80°C when running.

The types of oil to be used for lubricating discs should meet the following criteria:

- Good resistance to oxidation
- No friction modifying additive
- High viscosity index (>80)

The oils listed below (Table 2) meet these criteria.

The list is not exhaustive and other lines may be added. The viscosity of the oil to be selected varies depending on the temperature and running speed (measured on the ext. dia. of the flange).

Viscosity Running speed	Mineral oil			ATF
	ISO VG 22 > 12 m/s	ISO VG 32 > 12 m/s	ISO VG 46 < 12 m/s	> 12m/s
BP		Energol HLP-D32	Energol HLP-D46	Autran MBX
ESSO	Nuto H22	Nuto h 32	Nuto H 46	AT Dexron II
MOBIL	DTE 22	DTE Oil Light	DTE Oil Medium	ATF 220
SHELL	Tellus 22	Tellus 32	Tellus 46	Donax TM
ELF		Polytelis 32	Polytelis 46	Elfmatic G2

Table 2

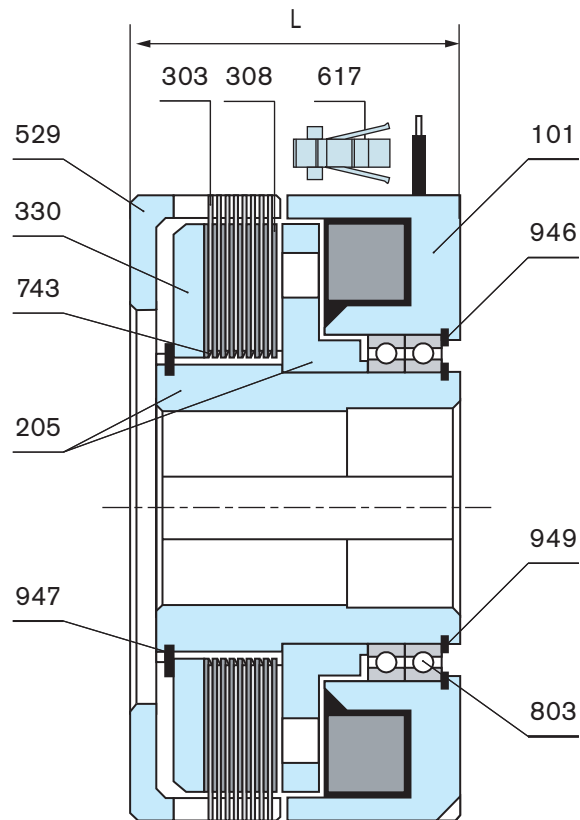

Ref. Nr	Description
101	Magnet
205	Rotor assembly
303	Steel outer disc
308	Steel inner disc
330	Moving armature
529	Driving flange
617	Connector kit
743	Wave washer
803	Centering ball bearing
946	Inside circlips
947	Outside circlips
949	Outside retainer