

■ **No backlash by the perfect integrated construction**

A perfect integral construction with a spiral slit in the round material.

■ **Excellent flexibility and high rigidity**

The high-strength aluminum alloy and spiral slit achieve an excellent flexibility and high torsional stiffness.

■ **High-corrosion resistance**

The high-strength aluminum alloy material and alumite treated surface ensure a high-corrosion resistance.

<b>Operating torque</b> [N·m]		0.3 ~ 39.0
<b>Bore processing finished product</b> [mm]		φ2 ~ 19
<b>Operational temp.</b> [°C]		-40 ~ +120
<b>Backlash</b>		Zero
<b>Max. permissible misalignment</b>	<b>Parallel offset</b> [mm]	0.15 ~ 0.25
	<b>Angular misalignment</b> [°]	3 ~ 5
	<b>Axial displacement</b> [mm]	±0.15 ~ ±0.25

■ **Excellent flexibility**

Allowing maximally 5° of angular misalignment

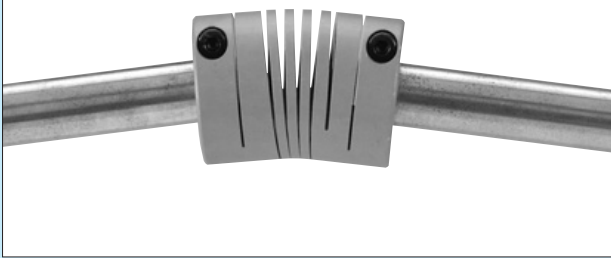

■ **High torsional stiffness (Double slit)**

The single-slit and double-slit models are available.

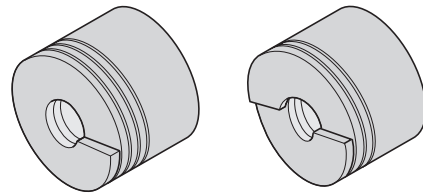

## Structure and Material

■ **ARM**

Body material: High-strength aluminum alloy (Equivalent of 7075 material)  
Surface treatment: Alumite treatment

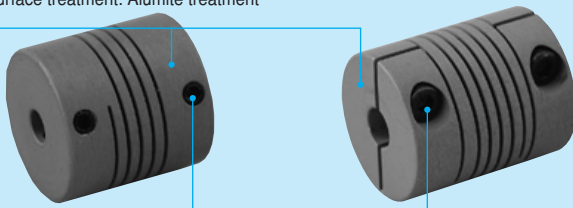

Screw material: SCM435  
Surface treatment: Oxide finish

- The A model with low inertia and high flexibility

■ **ACRM**

■ **DSR**

Body material: High-strength aluminum alloy (Equivalent of 7075 material)  
Surface treatment: Alumite treatment

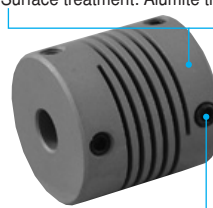

■ **DSCR**

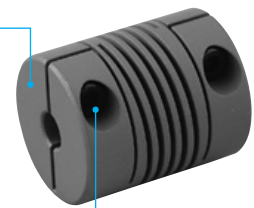

Screw material: SCM435  
Surface treatment: Oxide finish

- The DS model with low inertia and high torsional stiffness (double-slit type)

■ **1441**

Body material: Stainless steel

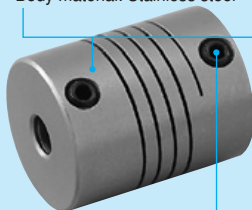

■ **3000 2M**

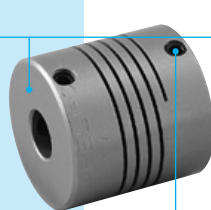

■ **3000 5M**

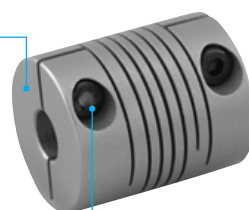

Screw material: SCM435  
Surface treatment: Oxide finish

- The 1411 and 3000 models with high-corrosion resistance (Stainless-steel body)

## Model list

Model	Normal operating torque [N·m]	Bore processing finished product [mm]	Max. permissible misalignment		
			Parallel offset [mm]	Angular misalignment [°]	Axial displacement [mm]
ARM	0.3 ~ 2.3	2 ~ 12	0.25	5	±0.25
ACRM	0.3 ~ 2.3	2 ~ 12	0.25	5	±0.25
1441	0.4	4 ~ 6	0.25	5	±0.12
3□□2M, 3□□5M	0.4 ~ 2.5	2 ~ 12	0.25	5	±0.25
DSR, DSCR	0.8 ~ 19.5	4 ~ 16	0.15	3	±0.15

### Torsional angle and torsional torque

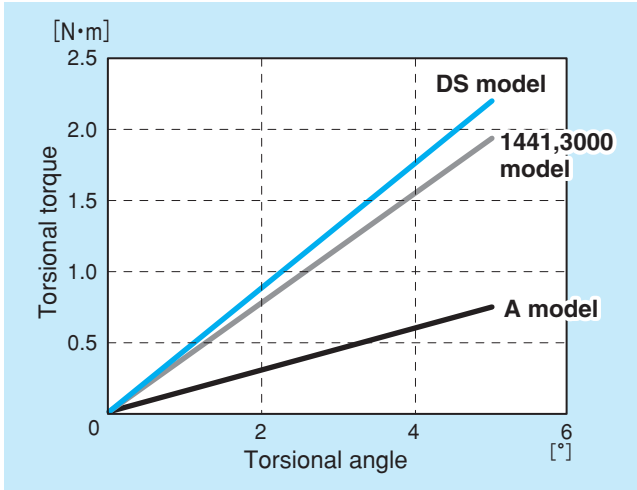

### Parallel offset and radial load

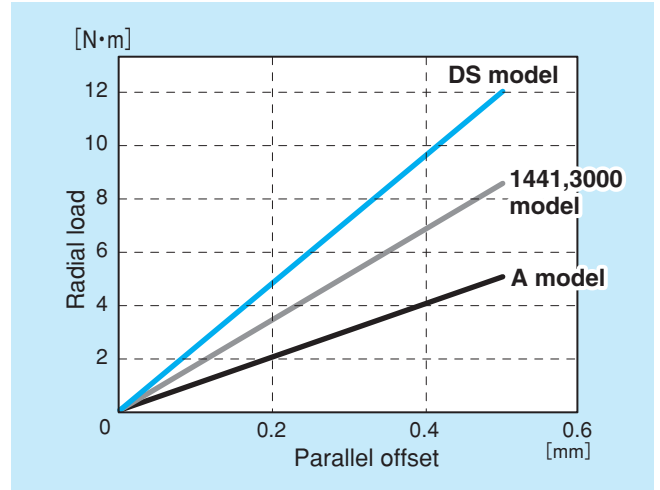

## Design check items

- More than necessary bending, compression or pulling applied during mounting or dismounting may result in coupling damage.
- The element provides excellent resistance to water, oil and chemicals. However, excessive water, oil and chemicals could cause a malfunction. Consult Miki Pulley beforehand if couplings are to be operated in such environment.
- Additional machining is not basically allowed to avoid an effect on the coaxial degree of the right and left bores and inside slit.
- Key processing is not recommended in consideration of damage of the slit part.
- If the rotation speed exceeds ( $2000\text{min}^{-1}$ ), misalignment must be less than 50% of the tolerance.
- Inlay alignment is recommended as a centering method of the right and left mounting shafts. As a measure of confirming its mounting accuracy, loosen the clamping bolts or setscrews after fixing the right and left shafts and check if the coupling smoothly rotates in the rotative direction or moves in the axial direction.

- After mounting a coupling, confirm there is no abnormal deformation as shown in the figure 1 or 2.

Parallel offset ( $\epsilon$ ) / Axial displacement (S)

Angular misalignment ( $\theta$ )

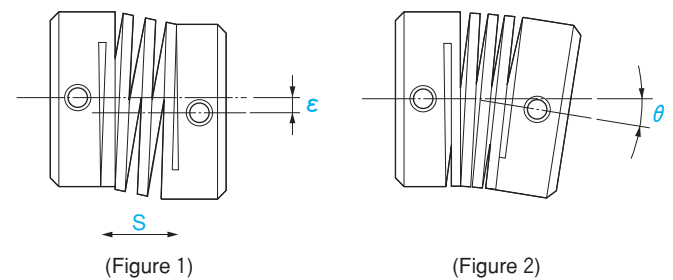

- Manage tightening of setscrews or clamping bolts at the following tightening torque by using a torque wrench or torque driver.

### Tightening torque list

	Setscrew [N·m]	Clamping bolt [N·m]
M1.6	—	0.25
M2	0.09	—
M2.5	—	1.0
M3	0.7	1.5
M5	3.6	7.0
M6	6.0	11.7

# ARM · ACRM

Helical-A Model



## Specification

Model	Torque		Max. permissible misalignment			Max. rotation speed [min <sup>-1</sup> ]	Torsional spring constant [N·m/rad]	Moment of inertia [kg·m <sup>2</sup> ]	Mass [kg]	Price
	Normal [N·m]	Max. [N·m]	Parallel offset [mm]	Angular misalignment [°]	Axial displacement [mm]					
ARM-050	0.3	0.6	0.25	5	±0.25	25000	4.1	9.20×10 <sup>-8</sup>	0.004	—
ARM-075	1.0	2.0	0.25	5	±0.25	25000	8.2	7.02×10 <sup>-7</sup>	0.013	—
ARM-100	1.6	3.2	0.25	5	±0.25	25000	14.3	2.87×10 <sup>-6</sup>	0.031	—
ARM-112	2.3	4.6	0.25	5	±0.25	25000	18.5	5.16×10 <sup>-6</sup>	0.038	—
ACRM-050	0.3	0.6	0.25	5	±0.25	10000	4.1	1.38×10 <sup>-7</sup>	0.006	—
ACRM-075	1.0	2.0	0.25	5	±0.25	10000	8.2	8.39×10 <sup>-7</sup>	0.015	—
ACRM-100	1.6	3.2	0.25	5	±0.25	10000	14.3	3.60×10 <sup>-6</sup>	0.035	—
ACRM-112	2.3	4.6	0.25	5	±0.25	10000	18.5	6.87×10 <sup>-6</sup>	0.050	—

- \* The normal operating torque becomes 1/2 during forward and reverse operation.
- \* Avoid operating couplings beyond maximum torque.
- \* The indicated prices are applied to the standard bore diameter.
- \* The indicated values in the moment of inertia and mass are measured with the maximum bore diameter.

## Dimensions

Helical

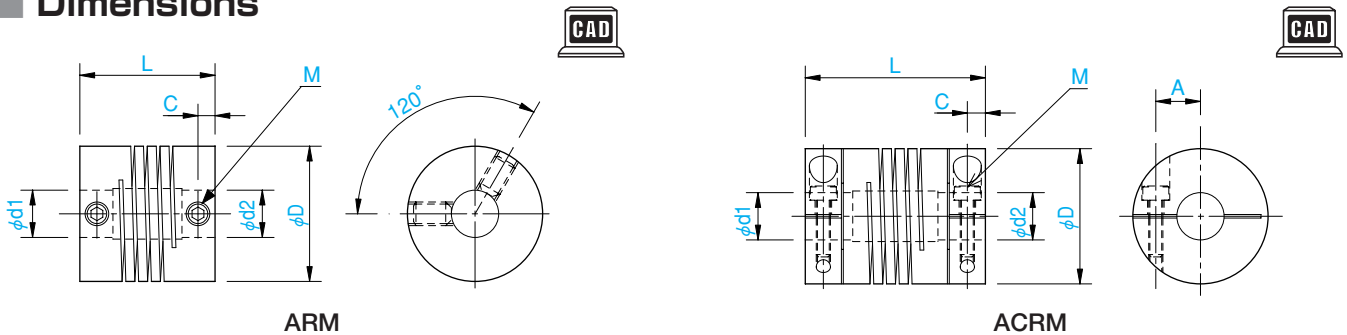

Unit [mm]

Model	Max. bore diameter	D	L	A	C	M	Tightening torque [N·m]	CAD file No.
ARM-050	3.17	12.7	12.7	—	1.6	M2	0.09	ARM1
ARM-075	6.35	19.1	19.1	—	2.4	M3	0.7	ARM2
ARM-100	10	25.4	25.4	—	3.8	M5	3.6	ARM3
ARM-112	12.7	28.6	28.6	—	3.6	M5	3.6	ARM4
ACRM-050	3.17	12.7	19.1	3.6	2.3	M1.6	0.25	ACRM1
ACRM-075	6.35	19.1	22.9	5.6	3.1	M2.5	1.0	ACRM2
ACRM-100	10	25.4	31.8	7.9	3.8	M3	1.5	ACRM3
ACRM-112	12.7	28.6	38.1	9.5	3.8	M3	1.5	ACRM4

## Ordering information

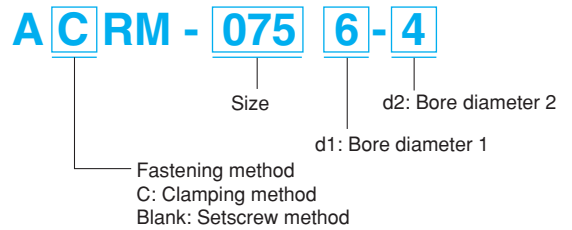

- \* The setscrew size for bore diameter (2) in ARM-050 is M1.6. The setscrew size for bore diameter (3) in ARM-075 is M1.2.
- \* The standard bore diameter tolerance is (d<sup>+0.05</sup>).
- \* The recommended machining tolerance of the mate mounting shaft is h7.

- \* d1 is for larger diameters.
- \* Consult Miki Pulley for bore diameters other than the standard.

## Standard bore diameter

Standard bore diameter [mm]	d1	3	3	4	4	5	5	6	6	6	6.35	6.35	6.35	7	8	8	8	8	8	9.5	9.525	9.525	10	10	10	10	10	10	10	11	11	12	12	12	12	12	12			
	d2	2	3	3	4	4	5	4	5	6	5	6	6.35	7	6	6.35	7	8	8	8	8	9.525	6	6.35	8	9.5	9.525	10	10	11	8	9.5	9.525	10	12	12	12	12		
ARM, ACRM-050	●	●																																						
ARM, ACRM-075		●	●	●	●	●	●	●	●	●	●	●	●	●																										
ARM, ACRM-100															●																									
ARM, ACRM-112																																								

# 1441·3□□2M·3□□5M

Helical1441 · 3000Model



## Specification

Model	Torque		Max. permissible misalignment			Max. rotation speed [min <sup>-1</sup> ]	Torsional spring constant [N·m/rad]	Moment of inertia [kg·m <sup>2</sup> ]	Mass [kg]	Price
	Normal [N·m]	Max. [N·m]	Parallel offset [mm]	Angular misalignment [°]	Axial displacement [mm]					
1441	0.4	0.8	0.25	5	±0.12	25000	21.2	9.82×10 <sup>-7</sup>	0.022	—
3042M	0.4	0.8	0.25	5	±0.25	25000	11.5	2.95×10 <sup>-7</sup>	0.012	—
3082M	1.3	2.6	0.25	5	±0.25	25000	22.0	2.01×10 <sup>-6</sup>	0.034	—
3002M	1.9	3.8	0.25	5	±0.25	25000	31.8	1.03×10 <sup>-5</sup>	0.101	—
3012M	2.5	5.0	0.25	5	±0.25	25000	52.1	1.97×10 <sup>-5</sup>	0.154	—
3045M	0.4	0.8	0.25	5	±0.25	10000	11.5	3.97×10 <sup>-7</sup>	0.015	—
3085M	1.3	2.6	0.25	5	±0.25	10000	22.0	2.41×10 <sup>-6</sup>	0.039	—
3005M	1.9	3.8	0.25	5	±0.25	10000	31.8	1.03×10 <sup>-5</sup>	0.101	—
3015M	2.5	5.0	0.25	5	±0.25	10000	52.1	1.97×10 <sup>-5</sup>	0.134	—

- \* The normal operating torque becomes 1/2 during forward and reverse operation.
- \* Avoid operating couplings beyond maximum torque.
- \* The indicated prices are applied to the standard bore diameter.
- \* The indicated values in the moment of inertia and mass are measured with the maximum bore diameter.

## Dimensions

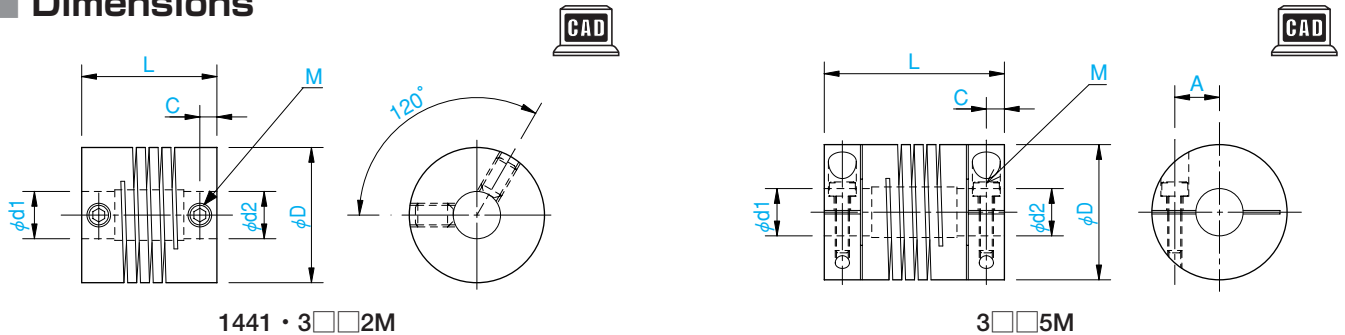

Unit [mm]

Model	Max. bore diameter	D	L	A	C	M	Tightening torque [N·m]	CAD file No.
1441	6	15.8	20.0	—	2.5	M3	0.7	14411
3042M	3.17	12.7	14.2	—	1.8	M2	0.09	3XX2M1
3082M	6.35	19.1	19.1	—	2.2	M3	0.7	3XX2M2
3002M	10	25.4	31.8	—	3.8	M5	3.6	3XX2M3
3012M	12.7	28.6	38.1	—	5.1	M5	3.6	3XX2M4
3045M	3.17	12.7	19.1	3.6	2.3	M1.6	0.25	3XX5M1
3085M	6.35	19.1	22.9	5.6	3.1	M2.5	1.0	3XX5M2
3005M	10	25.4	31.8	7.9	3.8	M3	1.5	3XX5M3
3015M	12.7	28.6	38.1	9.5	3.8	M3	1.5	3XX5M4

- \* The setscrew size for bore diameter (2) in 3042M is M1.6. The setscrew size for bore diameter (3) in 3082M is M2.
- \* The standard bore diameter tolerance is (d<sup>+0.05</sup>) for 1411 and (d<sup>+0.025</sup>) for 3□M model.
- \* The recommended machining tolerance of the mate mounting shaft is h7.
- \* For 1441 model, do not insert the shaft into the spring part. The length of shaft insertion must be above 5mm and below 6mm from the edge surface.

## Ordering information

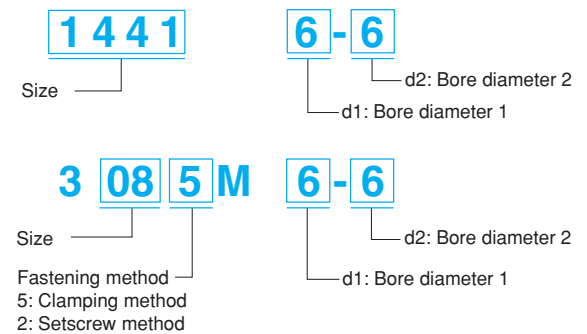

- \* d1 is for larger diameters.
- \* Consult Miki Pulley for bore diameters other than the standard.

## Standard bore diameter

Standard bore diameter [mm]	d1	3	3	4	4	5	5	6	6	6	6.35	6.35	6.35	7	8	8	8	8	8	8	9.5	9.525	9.525	10	10	10	10	10	10	10	11	11	12	12	12	12	12	12	
	d2	2	3	3	4	4	5	4	5	6	5	6	6.35	7	6	6.35	7	8	8	8	8	9.525	6	6.35	8	9.5	9.525	10	10	11	8	9.5	9.525	10	12				
1441					●					●																													
3042M, 3045M	●	●																																					
3082M, 3085M		●	●	●	●	●	●	●	●	●	●	●	●	●	●	●	●	●	●	●	●	●	●	●	●	●	●	●	●	●	●	●	●	●	●	●	●	●	●
3002M, 3005M										●				●	●	●	●	●	●	●	●	●	●	●	●	●	●	●	●	●	●	●	●	●	●	●	●	●	●
3012M, 3015M															●																								

### Specification

Model	Torque		Max. permissible misalignment			Max. rotation speed [min <sup>-1</sup> ]	Torsional spring constant [N·m/rad]	Moment of inertia [kg·m <sup>2</sup> ]	Mass [kg]	Price
	Normal [N·m]	Max. [N·m]	Parallel offset [mm]	Angular misalignment [°]	Axial displacement [mm]					
DSR-075	0.8	1.6	0.15	3	±0.15	25000	26.0	7.00×10 <sup>-7</sup>	0.012	—
DSR-100	1.8	3.6	0.15	3	±0.15	25000	50.3	2.87×10 <sup>-6</sup>	0.030	—
DSR-112	2.7	5.4	0.15	3	±0.15	25000	70.7	5.16×10 <sup>-6</sup>	0.037	—
DSR-150	6.3	12.6	0.15	3	±0.15	25000	204.6	2.20×10 <sup>-5</sup>	0.082	—
DSR-200	19.5	39.0	0.15	3	±0.15	25000	784.9	9.38×10 <sup>-5</sup>	0.200	—
DSCR-075	0.8	1.6	0.15	3	±0.15	10000	26.0	8.39×10 <sup>-7</sup>	0.014	—
DSCR-100	1.8	3.6	0.15	3	±0.15	10000	50.3	3.60×10 <sup>-6</sup>	0.036	—
DSCR-112	2.7	5.4	0.15	3	±0.15	10000	70.7	6.87×10 <sup>-6</sup>	0.050	—
DSCR-150	6.3	12.6	0.15	3	±0.15	10000	204.6	2.39×10 <sup>-5</sup>	0.091	—
DSCR-200	19.5	39.0	0.15	3	±0.15	10000	784.9	9.38×10 <sup>-5</sup>	0.200	—

- \* The normal operating torque becomes 1/2 during forward and reverse operation.
- \* Avoid operating couplings beyond maximum torque.
- \* The indicated prices are applied to the standard bore diameter.
- \* The indicated values in the moment of inertia and mass are measured with the maximum bore diameter.

Helical

### Dimensions

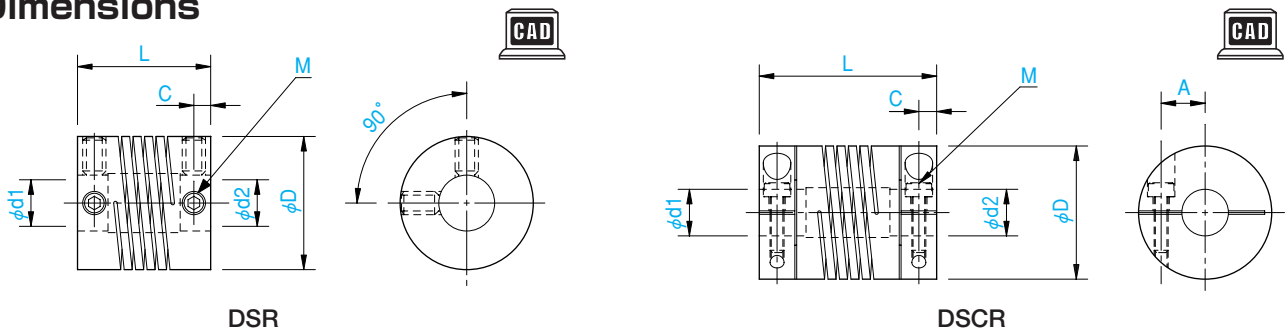

Unit [mm]

Model	Max. bore diameter	D	L	A	C	M	Tightening torque [N·m]	CAD file No.
DSR-075	6.35	19.1	19.1	—	2.4	M3	0.7	DSR1
DSR-100	10	25.4	25.4	—	3.8	M5	3.6	DSR2
DSR-112	12.7	28.6	28.6	—	3.6	M5	3.6	DSR3
DSR-150	15	38.1	38.1	—	5.0	M6	6.0	DSR4
DSR-200	19	50.8	50.8	—	7.0	M6	6.0	DSR5
DSCR-075	6.35	19.1	22.9	5.6	3.1	M2.5	1.0	DSCR1
DSCR-100	10	25.4	31.8	7.9	3.8	M3	1.5	DSCR2
DSCR-112	12.7	28.6	38.1	9.5	3.8	M3	1.5	DSCR3
DSCR-150	15	38.1	41.3	11.6	5.9	M5	7.0	DSCR4
DSCR-200	19	50.8	50.8	16.7	6.7	M6	11.7	DSCR5

### Ordering information

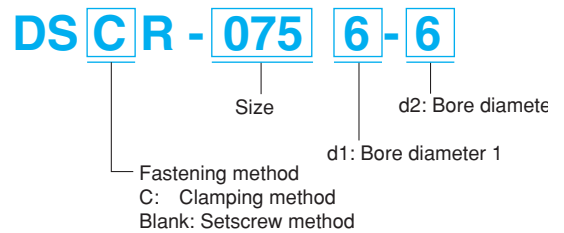

- \* d1 is for larger diameters.
- \* Consult Miki Pulley for bore diameters other than the standard.

- \* The standard bore diameter tolerance is (d<sup>+0.05</sup>).
- \* The recommended machining tolerance of the mate mounting shaft is h.7

### Standard bore diameter

Standard bore diameter [mm]	d1	4	5	5	6	6	6	6.35	6.35	6.35	7	8	8	8	8	9.5	9.525	9.525	10	10	10	10	11	11	12	12	12	12	12	14	14	14	15	16	16			
	d2	4	4	5	4	5	6	5	6	6.35	7	6	6.35	8	8	8	8	9.525	8	9.5	9.525	10	10	11	11	9.5	10	11	12	10	12	14	15	14	16			
DSR, DSCR-075	●	●	●	●	●	●	●	●	●																													
DSR, DSCR-100							●			●	●	●	●	●	●	●	●	●	●	●	●	●	●	●	●	●	●	●	●	●	●	●	●	●	●	●		
DSR, DSCR-112															●	●	●	●	●	●	●	●	●	●	●	●	●	●	●	●	●	●	●	●	●	●		
DSR, DSCR-150																									●	●		●	●	●	●	●	●	●	●	●	●	
DSR, DSCR-200																																			●	●	●	●

## Selection

### Selection Procedure

- Calculate torque  $T_a$  applied to the coupling based on the motor output  $P$  and coupling operating rotation speed  $n$ .

$$T_a \text{ [N}\cdot\text{m]} = 9550 \times \frac{P \text{ [kW]}}{n \text{ [min}^{-1}\text{]}}$$

- Calculate corrected torque  $T_d$  applied to the coupling after deciding the service factor  $K$  based on use and operating conditions.

$$T_d \text{ [N}\cdot\text{m]} = T_a \cdot K1 \cdot K2 \cdot K3 \cdot K4$$

$K1$ : Operating coefficient by load character

$K2$ : Corrected coefficient by operating hours

$K3$ : Corrected coefficient by starting · breaking frequency

$K4$ : Corrected coefficient by ambient temperature

- Select the size in order that the coupling permissible torque  $T_n$  becomes greater than the corrected torque  $T_d$ .

$$T_n \geq T_d$$



- Select the size in order that the maximum torque of the coupling  $T_m$  becomes greater than the peak torque  $T_s$  generated by the motor or driven machine, or both. Maximum torque is defined as torque which can be temporarily applied. For 8-hour operating time per day, it is about 10 times.

$$T_m \geq T_s \cdot K4$$

- If the required shaft diameter is over the maximum bore diameter of the selected size, select a coupling suiting it.

### Service Factor

#### Operating coefficient by load character: $K1$

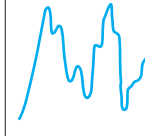
Load character			
Constant	Fluctuations: small	Fluctuations: medium	Fluctuations: large
			
1.0	1.25	1.75	2.25

#### Corrected coefficient by operating hours: $K2$

Hours/ per day	~8	~16	~24
<b>K2</b>	1.0	1.12	1.25

#### Corrected coefficient by starting/Breaking frequency: $K3$

Times/ per hour	~10	~30	~60	~120	~240	Over 240
<b>K3</b>	1.0	1.1	1.3	1.5	2.0	*

\* Consult Miki Pulley for over 240 times.

#### Corrected coefficient by ambient temperature: $K4$

Temp. [°C]	-20	0	+20	+40	+60	+80
<b>K4</b>	1.3	1.1	1.0	1.0	1.1	1.3

## Helical FLEXURE

# Helical flexure

(Available by special order)



The HELI-CAL FLEXURES are precision equipment manufactured by slitting cylindrical materials "spirally" by unique machining technology.

They are multipurpose and multifunctional products combining important functions such as a flexible shaft coupling, universal joint and precision spring.

The HELI-CAL FLEXURES are highly evaluated in various industries including electric, high-tech, space and aircraft industries. Various functions can be freely integrated in one part without being constrained by the conventional design concept.

- Single-piece construction
- Optional spring characteristics (Compression, tension, bending, shear and torsion)
- High-precision spring characteristic and dimensional precision are ensured.
- The attachments (spring ends) can be machined to any configuration in accordance with the intended use and shape.
- Material can be freely selected from aluminum alloy, stainless steel (corrosion resistance, magnetic and nonmagnetic), titanium or pure copper and other materials.
- Free design suiting applications is allowed.