



The Leader in Automated Test, Data Acquisition and Control Systems

# Battery Simulator 1200



## *Isolated channels with sink/source capabilities*

The Battery Simulator 1200 provides isolated channels to simulate battery sink and source characteristics often used for testing a Battery Management System (BMS). The instrument can be used standalone with the soft front panel, or integrated into a larger test system. Its proper industrial cooling and cell channel isolation allows units to be easily stacked, providing solutions with over 200 channels of simulation capability. The built in channel voltage and current readback reduces the need for external monitoring equipment.

## APPLICATIONS

- BMS testing, verification, and validation
- Battery pack simulation up to 200 cells
- Hardware-in-the-Loop (HIL) system integration

## FEATURES

- 12 independently controlled cell channels
- Sink and source 5VDC and 500mA per channel
- 1000V channel-to-channel and channel-to-ground isolation
- Auxiliary analog and digital I/O
- Ethernet (LAN) and high speed CAN control communications
- NI LabVIEW™ drivers
- FCC, CE certified

Learn more about Bloomy's complete BMS test offerings:

BMS HIL Test System  
BMS Validation System  
BMS Manufacturing Test System

## APPLICATION DIAGRAM

The Battery Simulator 1200 can be used in many test scenarios where high isolated cell simulation is required. Below is an example of integrating the Battery Simulator 1200 into a test system with two units (24 channels) stacked above an external power supply to provide an overall pack voltage of 800V. The auxiliary I/O is used for temperature and control I/O simulation.

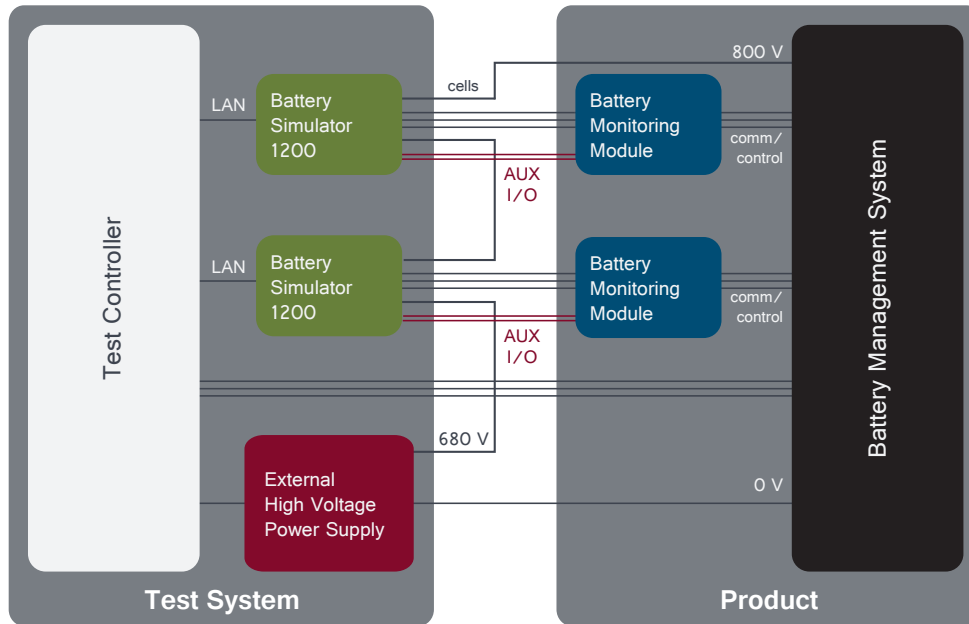

## HARDWARE SPECIFICATIONS

CELL CHANNEL SIMULATION	
Number of Channels	12
Channel Type	Sink and Source
Voltage Range	0.0 to 5.0V
Voltage Resolution	0.1 mV
Voltage Accuracy (requires remote sense)	±3 mV
Current Range	±500.0 mA (output derates linearly under 2 V)
Current Resolution	0.1 mA
Current Accuracy	±4 mA
Current Limiting Accuracy	±10 mA
Isolation Voltage	1000 VDC CH-TO-CH, CH-TO-GND
CHANNEL READBACK	
Voltage Resolution	0.1 mV
Voltage Accuracy	±3 mV
Current Resolution	0.1 mA
Current Accuracy	±4 mA
DIGITAL I/O	
Channels	8 (bidirectional)
Logic Level	3.3V

ANALOG OUTPUT	
Number of Channels	2
Voltage Resolution	0.1 mV
Voltage Accuracy	±5 mV
Max Voltage	5.0V
Max Current	10 mA
ANALOG INPUT	
Number of Channels	8 (single ended)
Max Voltage	5.0V
Voltage Resolution	0.1 mV
Voltage Accuracy	±5 mV
CONTROL	
Communication	LAN, CAN
Drivers	NI LabVIEW™
PHYSICAL	
Dimensions	19" W x 1.75" H x 15" D (1U) (482.6 mm W x 44.5 mm H x 381.0 mm D)
Weight	7.5 lbs (3.4 kg)
Operating Temperature	0 - 35°C

NOTE: Analog Input, Analog Output, and Digital I/O are unit options.