

RENOLD

ROLL-RING[®]

Self adjusting chain tensioner BS / ANSI standard chain



Self adjusting chain tensioner

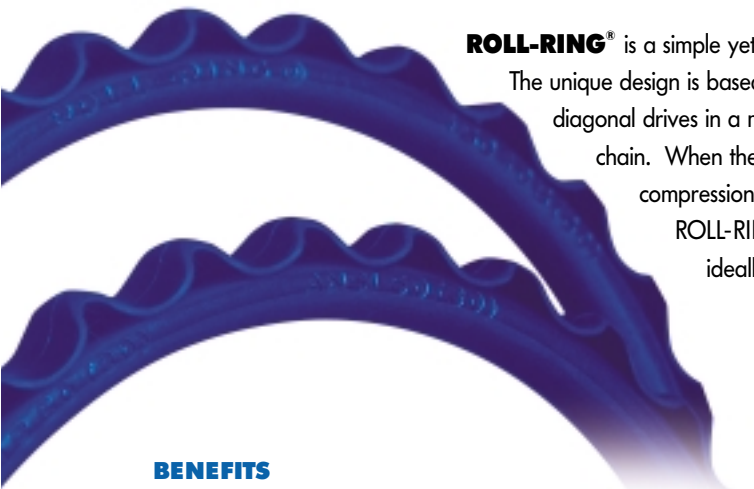

ROLL-RING® is a simple yet innovative chain tensioner made from a specially formulated polymer.

The unique design is based upon a simple toothed ring that can be fitted to horizontal, vertical or diagonal drives in a matter of seconds, simply by placing it in-between the two strands of chain. When the drive is in use, the ROLL-RING® deforms to an elliptical shape, due to compression between the strands and completely absorbs any slack in the system.

ROLL-RING® performs the job of a tensioner and a damper in one, and is ideally suited to applications where maintenance is difficult or impossible.

BENEFITS

The ROLL-RING® chain tensioner provides cost effective, time saving installation and maintenance.

The advantages over other types of chain tensioners are:

- Free standing - no sprockets, bolts, plates, drilling or costly installation required.
- The ROLL-RING® is easily installed where space limitations prohibit the use of conventional chain tensioners.
- The ROLL-RING® is fitted in a matter of seconds.
- It is ready for use without any tools, tensioning equipment or any further alignment or adjustment.
- It is fully effective in vertical and diagonal drives.
- The ROLL-RING® works automatically, is maintenance free and self lubricating.
- It can be used in dusty and dirty environments.
- The ROLL-RING® is a tensioner and damper in one, thus reducing noise levels.
- ROLL-RING® also works in reverse mode.

ROLL-RING® chain tensioners reduce chain wear and improve the quality and efficiency of the complete chain drive.



Snap-in installation

TECHNICAL DETAILS

ROLL-RING® chain tensioners provide tensioning using:

- Static tensioning force from the elastic ring
- Dynamic tensioning force from the damping of the working material

ROLL-RING® provides as much tensioning as possible at low chain speeds, and has reserves of tensioning and damping capability for higher chain speeds. The diagram below shows the tensioning force of a ROLL-RING® chain tensioner with its individual allocations of tensioning forces and their resulting effects.

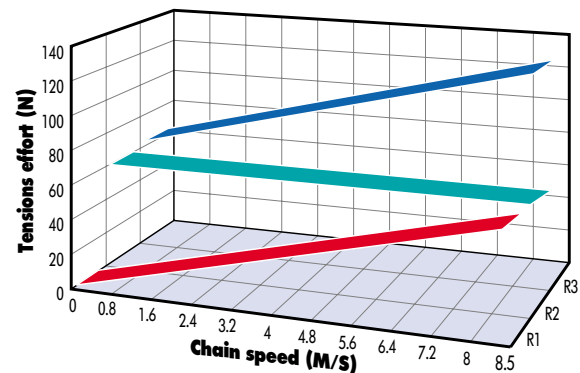

Tensioning effort for ROLL-RING®: Dynamic force R1 (red), Static force R2 (green), Resultant force R3 (blue)

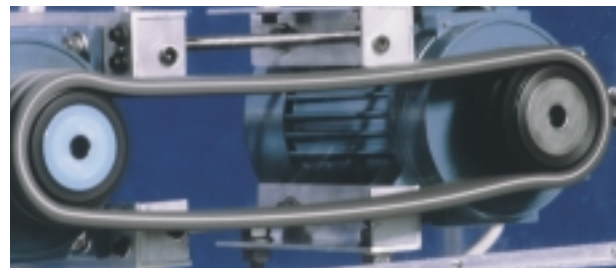

Vibrations in an untensioned chain drive

THE INNOVATIVE TENSIONER

The ROLL-RING® chain tensioner is an elementary mechanism based on new principles and represents a major advance in technology:

- ROLL-RING® requires minimal technical effort.
- Its operation is astonishingly simple.
- All functions are integrated into a single component.
- ROLL-RING® utilises the hollow space of the associated chain drive system giving greater flexibility to designers and specifiers.
- Automatic positioning and self lubricating.

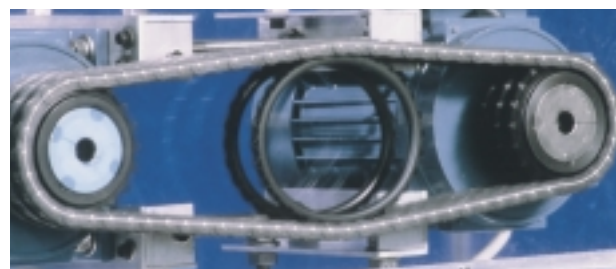

The ROLL-RING® chain tensioner tensions and dampens

Self adjusting chain tensioner

CASE STUDY: CHOCOLATE PRODUCTION

A major chocolate manufacturer was experiencing serious problems with short chain life on a main production line and also had chain tensioning problems, due to the inaccessibility of the chain drives. Firstly, the short chain life (4-5 weeks) was overcome when the Renold Engineer recommended a change to Renold brand, nickel plated chains, which has led to a new chain life of twelve months so far, and at time of going to press, the new Renold chains are still fitted.

Secondly, the downtime caused by the failure of the previous chains was extended, after the fitting of chain adjusters, due to the need for regular adjustment of the chain tensioners. With a time sensitive maintenance policy, the chocolate manufacturer looked for a solution to speed up the tensioning of the replacement chain and ROLL-RING® provided that simple solution. The new Renold chains had to be adjusted to be near their ideal sprocket centres when fitted, and with the necessary compression the ROLL-RING® was fitted by hand within seconds.

No further adjustments have had to be carried out due to the flexibility of the ROLL-RING® design and all future chain extension will be automatically taken up during the chains' life. With a large reduction in equipment downtime for tensioning adjustment, the chocolate manufacturer now enjoys significant time savings, cost savings and peace of mind.

- Saving of maintenance time for tension adjustments
- Simple installation
- Effective dampening
- Unique solution

THE NEW PRINCIPLE

The principle of the ROLL-RING® chain tensioner is based on two simple phenomena:

- The elastic ring engages with the chain drive strands and rolls between them in a pre-stressed condition taking up the shape of an ellipse
- The constantly opposing movements of the load and slack strands cancel each other out, thereby holding the ROLL-RING® in position

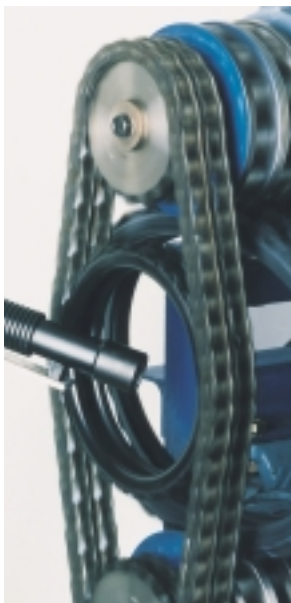

ROLL-RING® chain tensioners in one of our test rigs



ROLL-RING® chain tensioners are re-cyclable

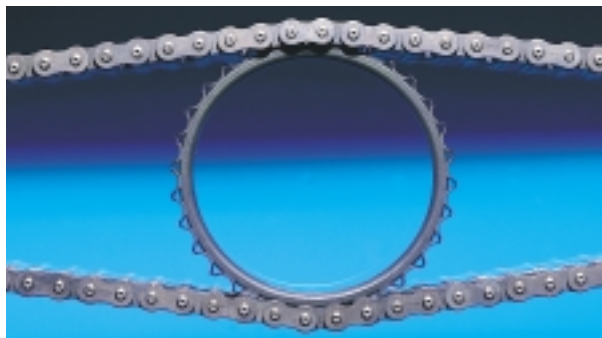

INSTALLATION AND MAINTENANCE

ROLL-RING® chain tensioners are maintenance free and can be fitted to a wide variety of chain drives with no installation down time.

The requirement is that:

- There is a working space with a gap between the chain strands which is smaller than the reference diameter of the chain tensioner.
- There is a sufficient gap between the chain drive sprockets.

We recommend that the chain tensioner is positioned between two chain strands such that there is at least one chain pitch between the ROLL-RING® and the smallest sprocket. The ROLL-RING® can also be positioned just as effectively outside this recommended area, as long as it is sufficiently pre-stressed. In this case, practical trial and error is recommended.

ROLL-RING® chain tensioners can be used in line within the same chain strand, or parallel with each other in multi-strand chain drives.

Please note that triplex chain drives only require two ROLL-RING® positioned on the outer strands.

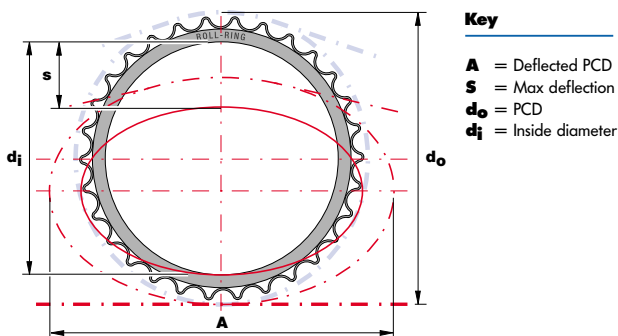

Renold ROLL-RING® (BS STANDARD) installation and final dimensions

Part number	d _o	d _i	s	A
10503001	76.5	65.0	20.0	104.0
10603001	91.1	73.0	25.0	122.0
10603601	109.3	89.5	25.0	143.0
10802601	105.3	84.5	24.0	135.8
10803001	121.5	98.0	28.0	161.6
10803401	137.5	115.4	30.0	165.0
11002601	131.7	105.0	28.0	153.0
11003001	151.8	124.6	33.0	177.0
11003401	172.0	141.0	38.0	217.0
11202601	158.0	127.6	35.0	209.5
11203001	182.2	145.0	40.0	241.7
11203401	206.5	169.5	45.0	265.0
11602601	210.7	167.0	45.0	269.0
11603001	243.0	202.0	50.0	306.0
12003001	303.7	244.0	60.0	390.0

Value A includes a safety distance to the sprockets.

Technical details

Renold ROLL-RING® chain tensioners standard product range

Part number	No. of teeth	ISO reference	Renold Chain reference	Maximum static expansive force **	Maximum chain speed	Minimum ambient temperature ~	Maximum ambient temperature ~	Resistance to ultra violet light
				(N)	(M/S)	(C)	(C)	
10503001	30	05B	110500	2.9	5.0	-20	70	Normal
10603001	30	06B	110038	15.2	5.2	-20	70	Normal
10603601	36	06B	110038	28.5	5.2	-20	70	Normal
10802601	26	08B	110046	15.7	7.5	-20	70	Normal
10803001	30	08B	110046	22.0	8.6	-20	70	Normal
10803401	34	08B	110046	22.0	8.8	-20	70	Normal
10843001	30	081 \ 083 *	111044 \ 6	16.8	7.5	-20	70	Normal
11002601	26	10B	110056	28.2	4.2	-20	70	Normal
11003001	30	10B	110056	23.0	8.8	-20	70	Normal
11003401	34	10B	110056	45.1	8.8	-20	70	Normal
11202601	26	12B	110066	39.2	5.4	-20	70	Normal
11203001	30	12B	110066	65.0	6.2	-20	70	Normal
11203401	34	12B	110066	70.5	6.4	-20	70	Normal
11602601	26	16B	110088	95.7	5.7	-20	70	Normal
11603001	30	16B	110088	108.5	6.2	-20	70	Normal
12003001	30	20B	110106	194.0	7.0	-20	60	Normal

Part number	No. of teeth	ANSI reference	Renold Chain reference	Maximum static expansive force **	Maximum chain speed	Minimum ambient temperature ~	Maximum ambient temperature ~	Resistance to ultra violet light
				(N)	(M/S)	(C)	(C)	
80603001	30	35	1129033	5.7	5.2	-20	70	Normal
10802601	26	40	119043	15.2	7.5	-20	70	Normal
10803001	30	40	119043	22.0	8.6	-20	70	Normal
10843001	30	41	119040	16.8	7.5	-20	70	Normal
11002601	26	50	119053	28.2	4.2	-20	70	Normal
11003001	30	50	119053	23.0	8.8	-20	70	Normal
11003401	34	50	119053	45.1	8.8	-20	70	Normal
11202601	26	60	119063	39.2	5.4	-20	70	Normal
11203001	30	60	119063	65.0	6.2	-20	70	Normal
11602601	26	80	119083	95.7	5.7	-20	70	Normal
81603001	30	80	119083	103.0	6.6	-20	70	Normal
12003001	30	100	119103	194.0	7.0	-20	60	Normal

Part number	No. of teeth	ISO reference	Renold Chain reference	Maximum static expansive force **	Maximum chain speed	Minimum ambient temperature ~	Maximum ambient temperature ~	Resistance to ultra violet light
				(N)	(M/S)	(C)	(C)	
20802601	26	08B	110046	13.5	7.1	-20	70	High #
20803001	30	08B	110046	20.4	7.4	-20	70	High #
20843001	30	081 \ 083 *	111044 \ 6	15.4	6.8	-20	70	High #
21003001	30	10B	110056	20.0	7.8	-20	70	High #
21202601	26	12B	110066	37.0	5.0	-20	70	High #
21203001	30	12B	110066	52.0	5.6	-20	70	High #
21603001	30	16B	110088	100.6	5.8	-20	70	High #
22003001	30	20B	110106	165.8	6.3	-15	60	High #

Ultra Violet resistant ROLL-RINGS® for use in equipment where the ROLL-RING® is exposed to Ultra Violet Light ie. agricultural machinery, community service equipment, building machines etc.

~ For special operational temperatures lower or higher than those listed please consult Renold.

* To fit all roller chain widths from 1/8 to 5/16".

** At 20°C maximum adjustment, without dynamic expansive force proportional to chain speed.

NB Ultra Violet resistant ROLL-RINGS® have different mechanical properties to the standard ROLL-RING® which could result in a lower service life.

The above information is based on current knowledge and experience, we reserve the right to make modifications as part of our technical product improvement programme.

The range of ROLL-RING® products continues to increase. Please consult Renold to discuss your particular requirements.

INDUSTRIES

Typical applications:

- Agricultural machinery
- Baggage handling
- Cardboard manufacture
- Ground compression machines
- Kiln conveyors
- Manufacture of drive systems
- Manufacture of pressing plants
- Paper cutting machines
- Printing machines
- Road building machines

- Robotics
- Roller drive systems
- Tile manufacture
- Transport systems
- Wood chip conveying
- Chocolate manufacture



Registered trademark
641 683 from Ebert

How to specify a Roll-Ring (ISO B)

B) Selecting individual type for assembly in existing chain drive ISO B Series:

1. Measure in the area of the intersection between the inner crossings tangents of the chain drive the widest distance of the strands which have been pulled apart, via the centers of the chain joints (e.g: $D^*=85\text{mm}$).
2. Measure the inner width between the sprockets. (e.g: $A^*=310\text{mm}$).
3. Determine the ISO No. of the chain (e.g: 08 B1- 1).
4. Enter this ISO No in the table shown.
5. Select the appropriate group in the column (e.g: 08 B).
6. Specify the article group (108 026 01, 108 030 01, 108 034 01).
7. Check within this article group to determine which of the articles fulfils the following values measured by you for the chain drive:

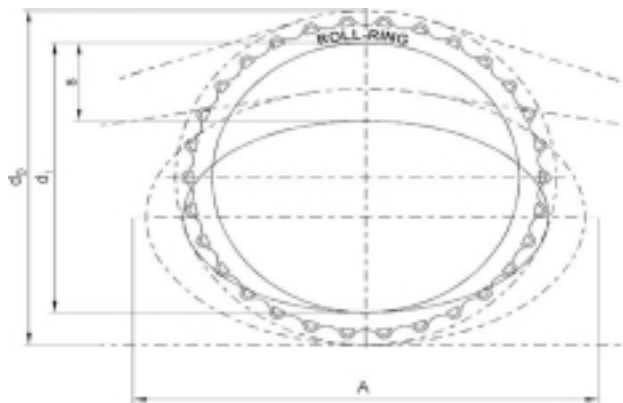
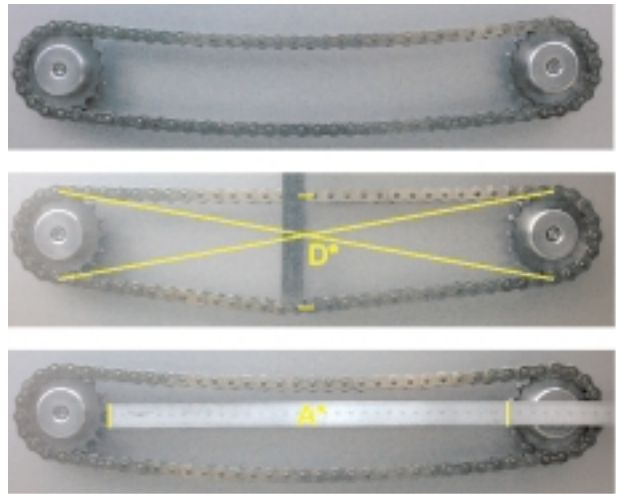

$D^* > D$ and $D^* < d$ (self-holding restriction) and $A^* > A$ (working area restriction).

ISO-No	Article	d_0	d_1	s	A	$D = d_0 - s$
05-B	105 030 01	76.5	65.0	20.0	104.0	56.5
06-B	106 030 01	91.1	73.0	25.0	122.0	66.1
06-B	106 036 01	109.0	89.0	25.0	143.0	84.0
08-B	108 026 01	105.5	87.5	27.0	135.0	78.5
08-B	108 030 01	121.5	101.6	30.0	161.6	91.5
08-B	108 034 01	137.5	115.4	30.0	165.0	107.5
08-B	108 430 01	121.5	101.6	30.0	161.6	91.5
10-B	110 026 01	128.4	105.0	28.0	153.0	100.4
10-B	110 030 01	148.0	124.6	33.0	177.0	115.0
10-B	110 034 01	170.0	141.0	38.0	217.0	132.0
12-B	112 026 01	155.0	127.6	35.0	209.5	120.0
12-B	112 030 01	182.2	153.1	45.0	242.0	137.2
12-B	112 034 01	207.5	169.5	45.0	265.0	162.5
16-B	116 026 01	207.0	167.0	45.0	269.0	162.0
16-B	116 030 01	245.8	202.0	50.0	306.0	195.8
20-B	120 030 01	303.7	65.0	65.0	390.0	238.7

How to specify a Roll-Ring (ANSI)

In order to select the type of Roll-Ring required, the existing chain drive needs to be assessed.

If you would like to select a Roll-ring chain tensioner for an already existing chain drive, independent of the transmission ratio, follow the instructions below to determine the fitting size and type of your tensioner.

Write your details clearly on the fax sheet provided and either fax, email or post the completed form to us.

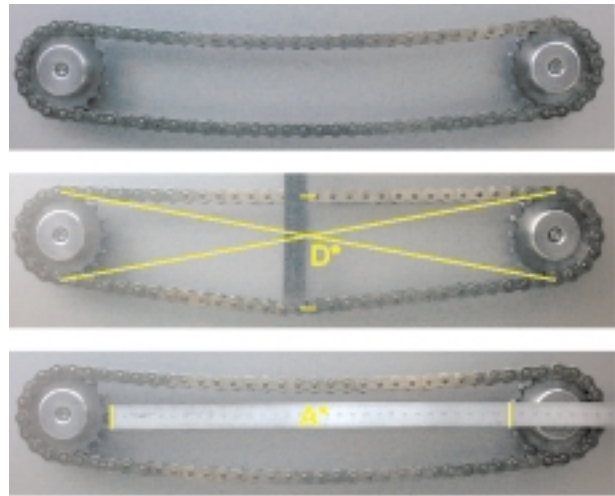

A) Selecting individual type for assembly in existing chain drive ANSI series:

1. Measure in the area of the intersection between the inner crossing tangents of the chain drive the widest distance of the strands which have been pulled apart, via the centers of the chain joints (e.g. $D^*=3.347$).
2. Measure the inner width between the sprockets (e.g. $A^*=12.205$).
3. Determine the ANSI No. of the chain (e.g. 40)
4. Enter this ANSI No. in the table shown.
5. Select the appropriate group in the column called - ANSI Column (e.g. 40)
6. Specify the article group (108 026 01, 108 030 01, 108 034 01)
7. Check within this article group to determine which of the articles fulfils the following values measured by you for A^* and D^* of the chain:

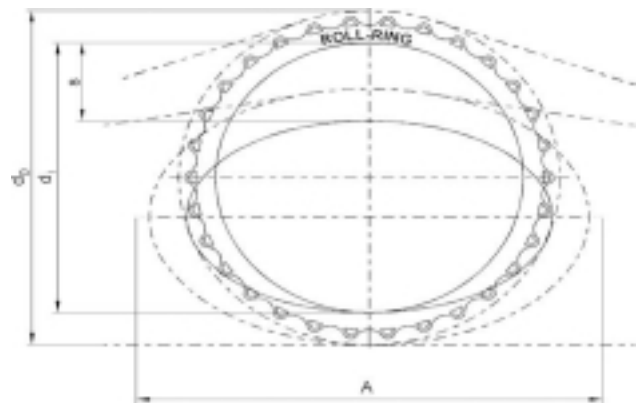

$D^* > D$ and $D^* < d$ (self-holding restriction) and $A^* > A$ (working area restriction)

ANSI-No	Article	d_0	d_1	s	A	$D = d_0 - s$
35	806 030 01	3.539	3.024	1.063	4.449	2.476
40	108 026 01	4.154	3.445	1.063	5.346	3.091
40	108 030 01	4.783	4.000	1.181	6.362	3.602
40	108 034 01	5.413	4.543	1.181	6.496	4.232
40	108 430 01	4.783	4.000	1.181	6.362	3.602
50	110 026 01	5.055	4.134	1.102	6.024	3.953
50	110 030 01	5.827	4.906	1.299	6.969	4.528
50	110 034 01	6.693	5.551	1.496	8.543	5.197
60	112 026 01	6.102	5.024	1.378	8.248	4.724
60	112 030 01	7.173	6.028	1.772	9.528	5.401
60	112 034 01	8.169	6.673	1.772	10.433	6.397
80	116 026 01	8.150	6.575	1.772	10.591	6.378
80	816 030 01	9.528	7.874	1.969	12.402	7.559
100	120 030 01	11.957	10.094	2.560	15.354	9.397