



**RIFTEK**  
Sensors & Instruments



## **Laser Inspection System**

**RF096-Insp**

**User's manual**

## Contents

1	Safety precautions.....	3
2	Electromagnetic compatibility.....	3
3	Laser safety.....	3
4	General information.....	3
5	Basic technical data.....	4
6	Example of item designation when ordering.....	4
7	Structure and operating principle.....	5
8	Dimensions and mounting.....	5
8.1	Overall and mounting dimensions.....	5
8.2	Overall demands for mounting.....	6
9	Connection.....	6
9.1	Designation of connector contacts.....	6
9.2	Cables.....	6
10	Indended use.....	7
10.1	Preparation for use.....	7
10.1.1	External examination.....	7
10.1.2	Setup on robot.....	7
10.1.3	Adjustment.....	7
11	Operating the system.....	7
12	Service program.....	8
12.1	Function.....	8
12.2	Network setting.....	8
12.3	Work with program.....	9
12.4	Parameters.....	10
13	Warranty policy.....	10
14	Distributors.....	11

## 1 Safety precautions

- Use supply voltage and interfaces indicated in the system specifications.
- In connection/disconnection of cables, the system power must be switched off.
- Do not use the system in locations close to powerful light sources.

## 2 Electromagnetic compatibility

The system have been developed for use in industry and meets the requirements of the following standards:

- EN 55022:2006 Information Technology Equipment. Radio disturbance characteristics. Limits and methods of measurement.
- EN 61000-6-2:2005 Electromagnetic compatibility (EMC). Generic standards. Immunity for industrial environments.
- EN 61326-1:2006 Electrical Equipment for Measurement, Control, and Laboratory Use. EMC Requirements. General requirements.

## 3 Laser safety

The system makes use of an c.w. 660 nm wavelength semiconductor laser. Maximum output power is 1 mW. The system belongs to the 2 laser safety class according to IEC 60825-1:2007. The following warning label is placed on the laser body:

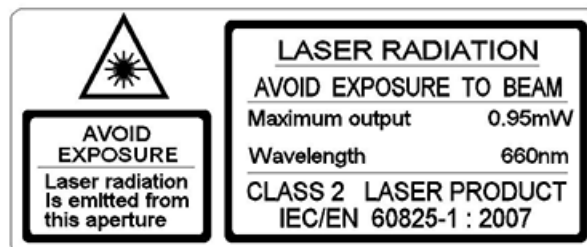

The following safety measures should be taken while operating the system:

- Do not target laser beam to humans;
- Do not disassemble the laser sensor;
- Avoid staring into the laser beam.

## 4 General information

The system is intended for non-contact detection of the debris inside the circular grooves of different technological items, for example brake calipers and so on. The system can be used also for groove seal profiling (seal deformation inspection). Custom-ordered configurations are possible with parameters different from those shown below.

## 5 Basic technical data

Parameter		Value
Inspected grooves diameter range, mm		35...53
Minimal size of detected debris, mm		0,03 (thickness) x 0,1 x 0,1
Space resolution (points/turnover)		3200
Laser sensor linearity, $\mu\text{m}$		$\pm 10$
Inspection time, s		1,2
Light source		red semiconductor laser, 660 nm wavelength
Output power, mW		<1
Laser safety Class		2 (IEC60825-1)
Laser beam shape		Round
Laser spot size, mm		0,1 (beginning of the range) - 0,2 (middle of the range) - 0,35 (end of the range)
Output interface	parameterization, profile data and inspection result transfer	Ethernet (UDP)
	logical (AL)	0...1 (low level) - power supply (high level), V
Command input (IN)		0...1 (low level) - 4,5...24 (high level), V
Power supply, V		9 ...24
Power consumption, W		3 (standby mode) , 20 (scan mode)
Environment resistance	Enclosure rating	IP67
	Vibration	20g/10...1000Hz, 6 hours, for each of XYZ axes
	Shock	30 g / 6 ms
	Operation temperature, $^{\circ}\text{C}$	-10...+60, (-30...+60 for the sensors with in-built heater),
	Permissible ambient light, lx	30000
	Relative humidity	5-95% (no condensation)
	Storage temperature	-20...+70 , $^{\circ}\text{C}$
Housing material		aluminum
Weight (without cable)		1100 gram + magnet holder (280 gram)

## 6 Example of item designation when ordering

RF096-Insp-Dmin/Dmax-M

Symbol	Description
Dmin	Minimal diameter for inspection, mm
Dmax	Maximal diameter for inspection, mm
M	Cable length, m

**Example:** RF096-Insp-45/63-3 – Laser inspection system RF096, diameter inspection range 45...63 mm, 3 m cable length.

## 7 Structure and operating principle

Operation of the system is based on the scanning of the item surface by binocular triangulation laser sensor.

The system contains laser sensor mounted on rotating module (Figure 1.). Radiation of a semiconductor laser from the sensor is focused onto an item surface. Radiation reflected by the surface is collected by two input lens of the sensor. The sensor is rotated and scans the surface. Distance to the surface, measured by laser sensor and corresponding angle of rotation form polar coordinates of the surface. In-built signal processor analyzes the surface profile and detects the presence of debris on the surface.

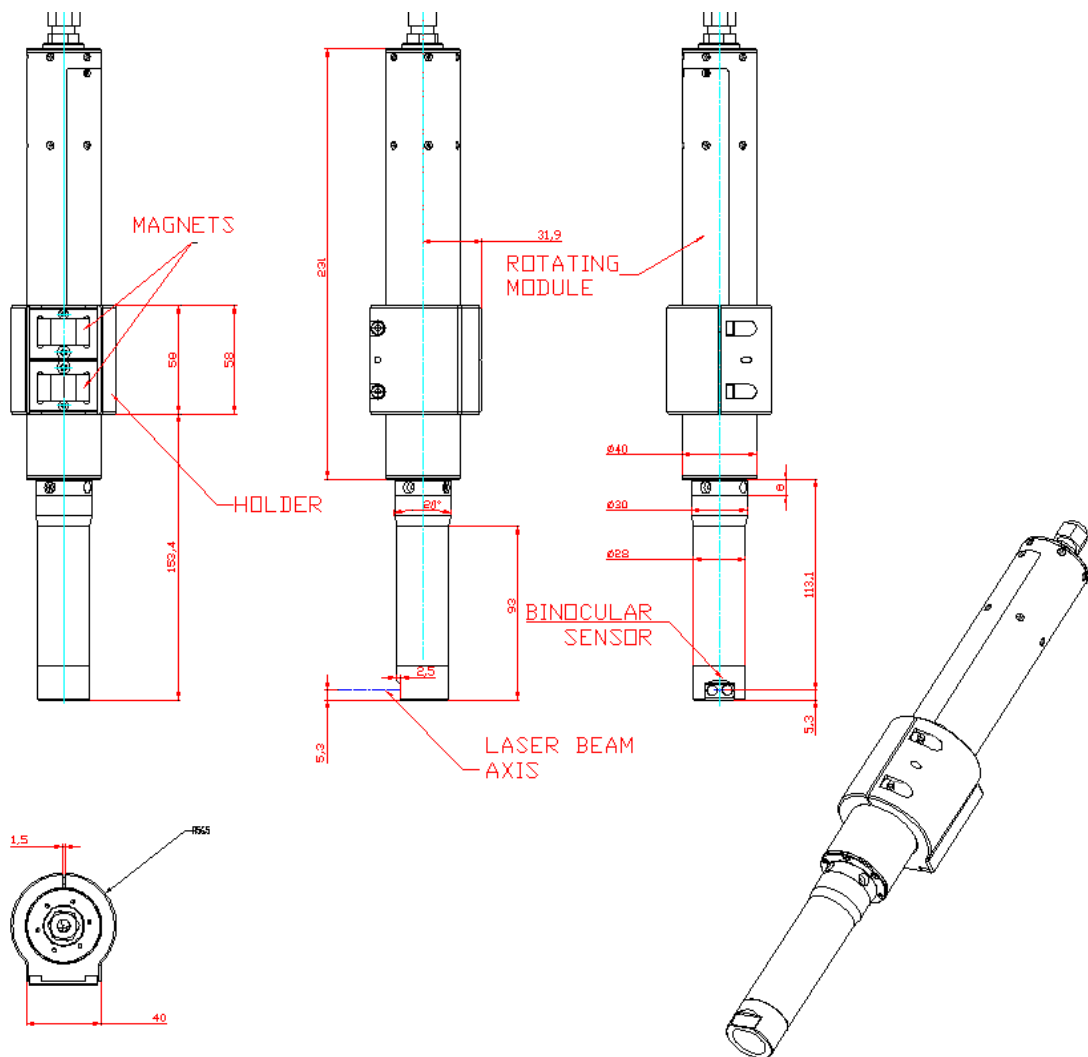

Figure 1

## 8 Dimensions and mounting

### 8.1 Overall and mounting dimensions

Overall and mounting dimensions of the system are shown in Figure 1. System package is made of anodized aluminum. The front panel of the laser sensor has glass window for laser beam output and for receiving radiation reflected from the object under control. The system also contains mounting frame with magnets. System is equipped by connector.

## 8.2 Overall demands for mounting

The system is positioned so that object under control (brake caliper groove, for example) should place in the working range of the system and on the laser beam axis.

## 9 Connection

### 9.1 Designation of connector contacts

View from the side of connector contacts used in the system is shown in the following figure.

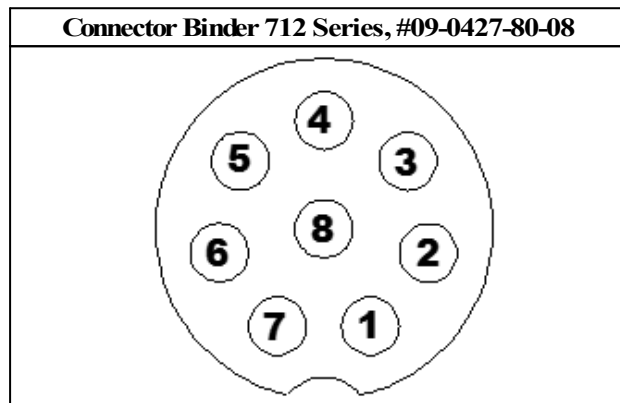

Designation of contacts is given in the following table:

Pin number	Assignment
1	TX+
2	Power-
3	RX-
4	AL (output)
5	IN (input)
6	TX-
7	RX+
8	Power+

### 9.2 Cables

Designation of cable wires is given in the table below:

Pin number	Assignment	Wire color	
RJ-45	1	TX+	White-orange
RJ-45	2	TX-	Orange
RJ-45	3	RX+	White-green
RJ-45	6	RX-	Green
free lead	-	AL (output)	White-blue
free lead	-	Power+	Blue
free lead	-	IN (input)	White-brown
free lead	-	Power-	Brown

## 10 Indended use

### 10.1 Preparation for use

Preparation of the system includes:

- external examination;
- set up on a linear translation system or robot and connection to power supply and controller;
- adjustment according to the item for inspection

#### 10.1.1 External examination

Before operating it is needed to ensure of the serviceability of the equipment, check the cable, ground wire. Check the condition of output window and, if necessary, wipe them with a soft cloth. Rotate laser sensor by hand and check smooth progress.

#### 10.1.2 Setup on robot

Install the system on a robot or linear translation system by using of magnet holder, see Fig. 1. (Note: as an option, the system can be fixed and the robot sets the item in control position). Make the electrical connections in accordance with cable wires designation. Ethernet interface is used for profile data and inspection result transfer and system parameterization, but for main work with the system you may use two logical lines only, see the next chapter.

#### 10.1.3 Adjustment

The system is positioned so that object under control (brake caliper groove, for example) should place in the working range of the system and on the laser beam axis. Some of the recommendations for adjustment are presented in the next chapter

## 11 Operating the system

The inspection cycle is fully automated and operation of the system is reduced to the work with two logical signals.

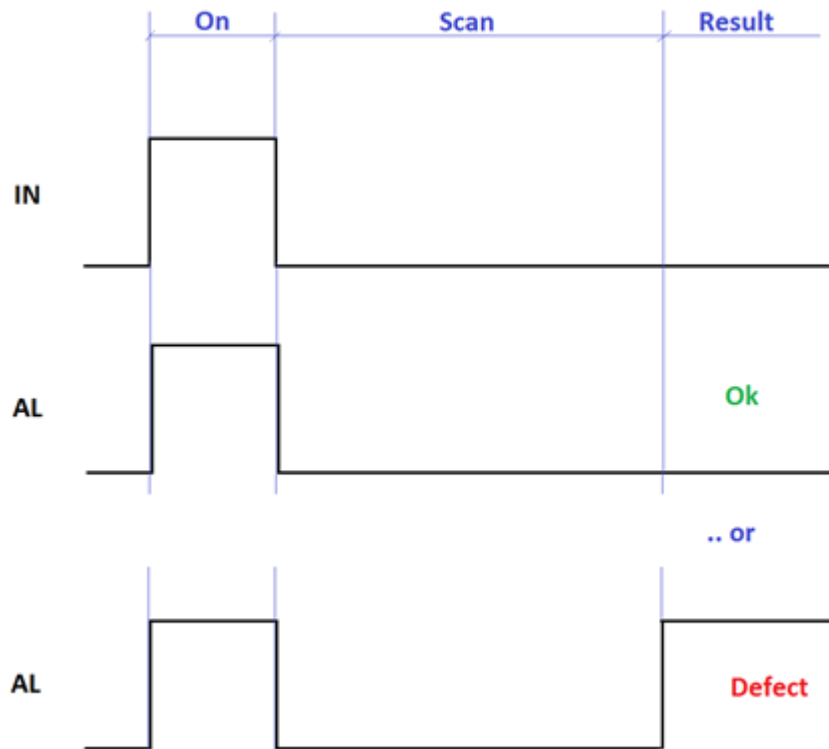

8

1. To start inspection cycle set high logic level on IN input. By the wave-rise of the IN pulse (transition to high level) triangulation sensor turns laser ON. (**NOTE:** this state (high level on IN input) can be so long as you need, so you can use it for visual adjustment of laser beam according to the groove. To do it set level HIGH, rotate laser sensor by hand and check position of laser spot along all the groove).
2. Set low logic level on IN input. By the wave-fall on the IN pulse (transition to low level) rotation module begins to rotate laser sensor. **NOTE:** You may use AL output to control connection between the system and controller. AL output repeats signal the system gets on IN input.
3. Laser sensor makes one revolution (scans all the groove)
4. The system transmits result of inspection on AL output. Low level - OK (no debris), High level - debris detected.
5. To inspect the next item repeat points 1-4.

## 12 Service program

### 12.1 Function

The service software is intended for:

- Testing and demonstration of work of the Inspection system;
- Setting of the some system parameters;

### 12.2 Network setting

All systems are shipped with the following default network configuration: IP address of the system – 192.168.0.3.

Configure your PC's network card in the next address space: 192.168.0.X. Connect system directly to PC or through network switch.



## 12.3 Work with program

You can download service program from this address: <https://riftek.com/media/documents/rf096/RF096-Insp-SP.ZIP>

Once the program is started, the main window emerges:

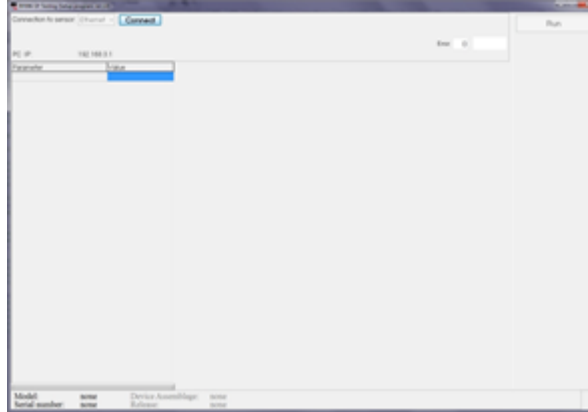

Where: PC IP is IP address of PC. **NOTE:** This PC address has to be recorded in the text file "PC IP", placed in the folder with a program.

Press **Connect** button for connection to the sensor. If connection is successful the name of button changes to **Disconnect**.

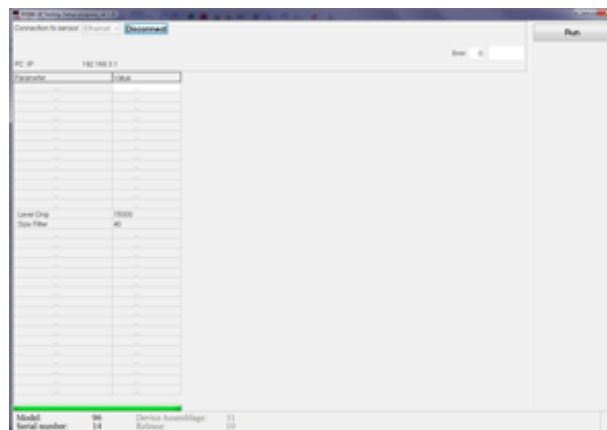

To start inspection cycle press button **Run**

Laser sensor makes one revolution and the program shows the result of inspection - **OK** or **Defect**

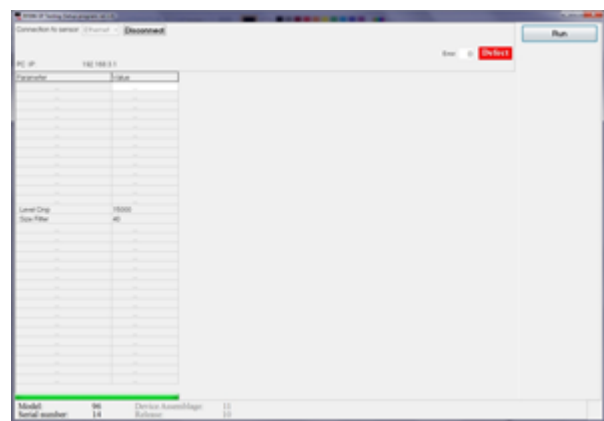
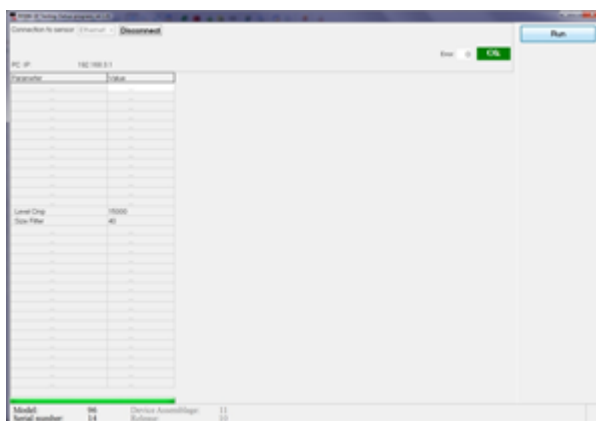

## 12.4 Parameters

You can change and customize two parameters of the system:

- Level CMP. It is a threshold level for digital filter that is used to search defects on surface profile. Increasing this parameter allows to decrease the influence of profile noise.
- Filter size. It is a size of filter. Increasing this parameter allows to decrease the the influence of profile noise on inspection result.

When working with the parameters, it should be borne in mind that when power is OFF the parameter values are stored in nonvolatile FLASH-memory of the system. When power is ON, the parameter values are read out to RAM of the system. In order to retain these changes for the next power-up state click the right key of the mouse on the Parameters panel Parameters save menu is activated. Select Write to FLASH. The system will operate with these parameter settings in subsequent switched on.

## 13 Warranty policy

Warranty assurance for the RF096 Laser Inspection system - 24 months from the date of putting in operation; warranty shelf-life - 12 months