

TABLE OF CONTENTS

L 20 SERIES Hydraulic Cylinders



150	Features	156	50mm	Bore
151	How to Order	157	63mm	Bore
152	Engineering Data	158	76mm	Bore
153	25mm Bore	159	101mm	Bore
154	32mm Bore	160	Rod End Options	
155	40mm Bore	161	Rod Extensions	

L20 SERIES

HYDRAULIC CYLINDERS

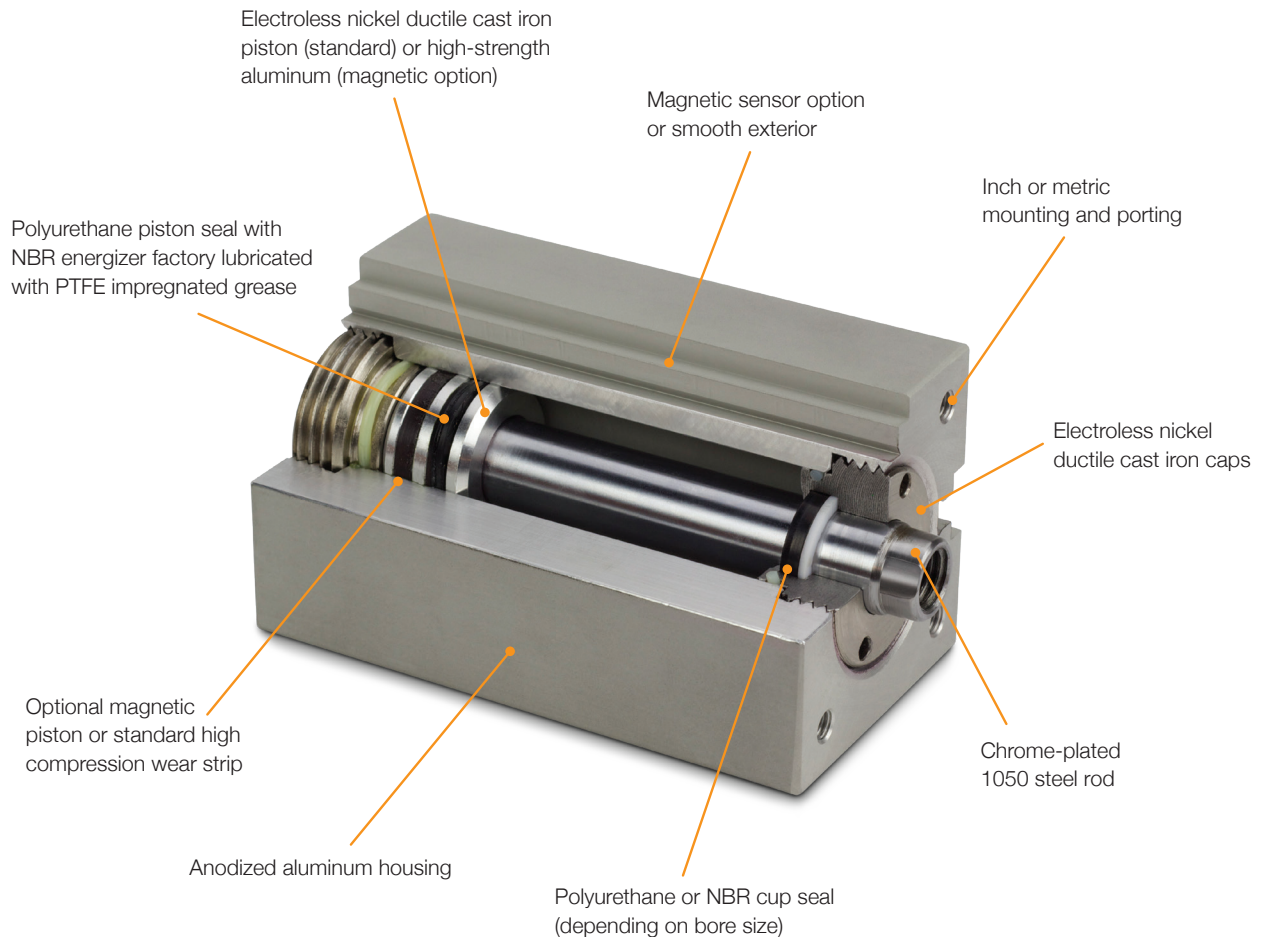

Common Features

Nason's L20 series hydraulic actuators were designed to be compact, long-lasting devices for today's demanding design requirements. They are offered in single and double rod configurations with inch or metric mounting and ports.

Compact Size

Nason L20 series cylinders were designed with today's automation equipment in mind. They offer more power in a smaller package than comparable NFPA style hydraulic cylinders without sacrificing performance.

Rugged Construction

The L20 series incorporates thick-walled, anodized aluminum housing. The rods are

chrome-plated 1050 steel riding in electroless nickel-plated ductile cast iron rod bearings. The piston on non-magnetic models is ductile cast iron with wear rings standard. The optional magnetic piston is manufactured from a high-strength aluminum. Rod wipers are standard on all models.

Versatile Design

The L20 series cylinders are metric in design (bore and rod sizes). They are offered in inch or metric mounting and porting. Due to their 100% machined design, they are easily customized by Nason.

Rebuildable

All L20 series cylinders are field-rebuildable.

How to Order

Example:

Part Number: L20-25X50MB-EMRM

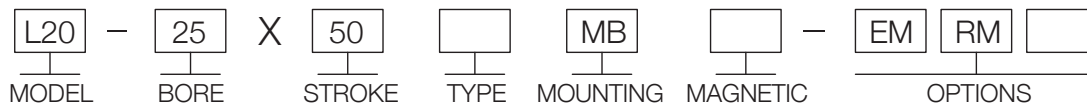

MODEL
L20 - Medium Pressure Cylinder

BORE
25 - 25mm (.98")
32 - 32mm (1.26")
40 - 40mm (1.58")
50 - 50mm (1.97")
63 - 63mm (2.48")
76 - 76mm (3.00")
101 - 101mm (4.00")

STROKE
See Stroke Table

TYPE
Blank (NO CODE) - Double Acting, Single Rod
D - Double Acting, Double Rod

MOUNTING
MF - Threads on Front Face (Rod End)
MR - Threads on Rear Face (Opposite Rod)
MB - Threads on Both Faces
MT - Drilled Through and Counter bored for Bolt Clearance

MAGNETIC
Blank (No Code) - Standard "NO MAGNET" Piston
M - Magnetic Piston and Sensor Mounting

OPTIONS
EM - Inch Threads (Mounting, Ports and Rods)
RM - Rod Male Threads
RF - 5mm (.197") Rod Extension
RT - 10mm (.394") Rod Extension
RN - 15mm (.591") Rod Extension
RY - 20mm (.787") Rod Extension
RV - 25mm (.984") Rod Extension
RH - 35mm (1.38") Rod Extension

Packing: Urethane and Buna N
 Lubrication: PTFE impregnated grease
 Stroke Tolerance: +1,0mm/-0mm (+0.04"/-0")

Piston Area Chart

Bore	PUSH (ROD EXTEND)	PULL (ROD RETRACT)
25	4,91cm ² (.76in ²)	3,37cm ² (.52in ²)
32	8,04cm ² (1.25in ²)	5,50cm ² (.85in ²)
40	12,57cm ² (1.95in ²)	8,77cm ² (1.36in ²)
50	19,63cm ² (3.04in ²)	13,48cm ² (2.09in ²)
63	31,17cm ² (4.83in ²)	20,99cm ² (3.25in ²)
76	45,60cm ² (7.07in ²)	29,70cm ² (4.60in ²)
101	81,07cm ² (12.57in ²)	56,44cm ² (8.75in ²)

Stock Strokes

Bore	Stroke
25	25mm, 50mm, 75mm, 100mm (.98", 1.96", 2.95", 3.93")
32	
40	
50	
63	
76	
101	

5mm increments available with additional lead time

Cylinder Output Force Formula

Piston Area x Pressure = Output Force
Piston Area(in ²) x Pressure(PSI) = lbf (Pounds Force)
Piston Area(cm ²) x Pressure(kg/cm ²) = kgf (Kilograms Force)
Piston Area(cm ²) x Pressure(kg/cm ²) x 9.8 = Newtons
Piston Area(cm ²) x Pressure(Bar) x 10 = Newtons
Piston Area(cm ²) x Pressure(Bar) x 1.02 = kgf (Kilograms Force)

Cylinder Ratings

Bore	Pressure	Temperature
25	140 BAR (2030 PSI)	-10° C to 80° C (14° F to 176° F)
32	140 BAR (2030 PSI)	-10° C to 80° C (14° F to 176° F)
40	140 BAR (2030 PSI)	-23° C to 100° C (-10° F to 212° F)
50	120 BAR (1740 PSI)	-23° C to 100° C (-10° F to 212° F)
63	100 BAR (1450 PSI)	-23° C to 100° C (-10° F to 212° F)
76	100 BAR (1450 PSI)	-23° C to 100° C (-10° F to 212° F)
101	100 BAR (1450 PSI)	-23° C to 100° C (-10° F to 212° F)

Front Mount Cylinder "MF"

MODEL	TYPE	STANDARD STROKES	"A"	PISTON AREA
L20	_D	25mm, 50mm, 75mm, 100mm	45,0(1.77")	PUSH 4,91 cm ² (0.76 in ²) PULL 3,37 cm ² (0.52 in ²)

	Standard Threads	"EM" Option
"B"	G1/8	#2 SAE
"C"	M10X1,5	3/8-24
"D"	M5X0,8	#10-32

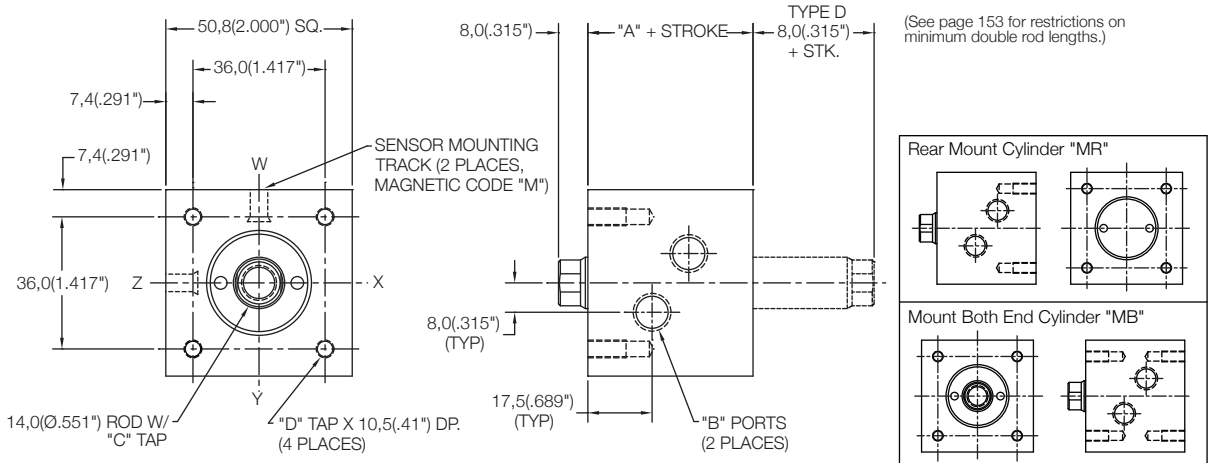

Thru Mount Cylinder "MT"

MODEL	TYPE	STANDARD STROKES	"A"	PISTON AREA
L20	_D	25mm, 50mm, 75mm, 100mm	45,0(1.77")	PUSH 4,91 cm ² (0.76 in ²) PULL 3,37 cm ² (0.52 in ²)

	Standard Threads	"EM" Option
"B"	G1/8	#2 SAE
"C"	M10X1,5	3/8-24

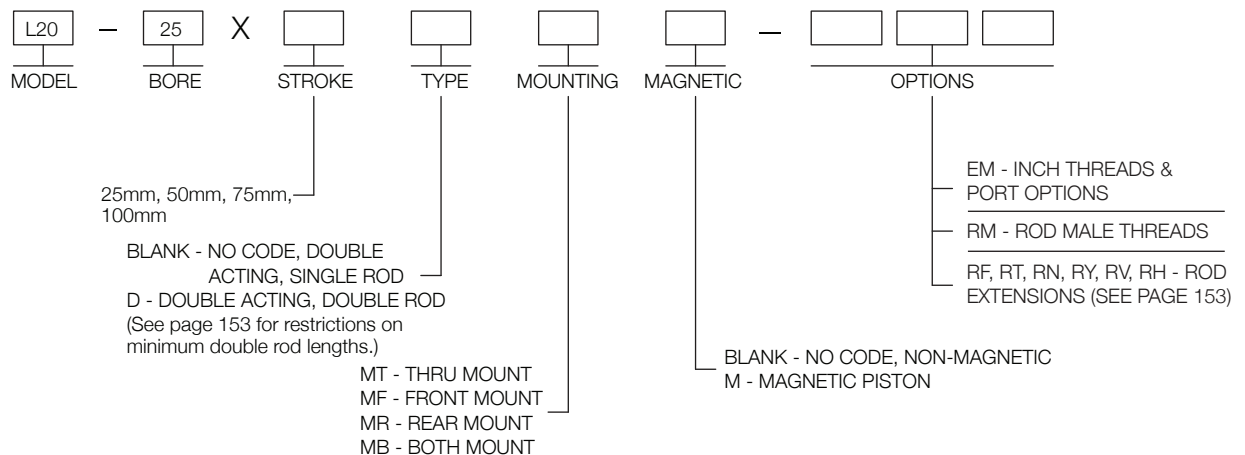
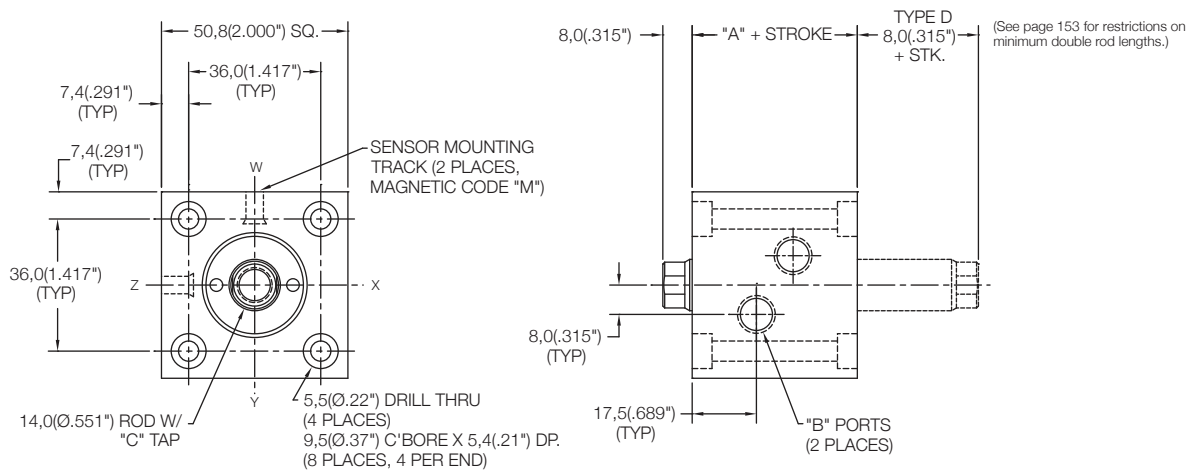

Front Mount Cylinder "MF"

MODEL	TYPE	STANDARD STROKES	"A"	PISTON AREA
L20	_,D	25mm, 50mm, 75mm, 100mm	51,0(2.01")	PUSH 8,04 cm ² (1.25 in ²) PULL 5,50 cm ² (0.85 in ²)

	Standard Threads	"EM" Option
"B"	G1/4	#4 SAE
"C"	M12X1,75	7/16-20
"D"	M6X1	1/4-28

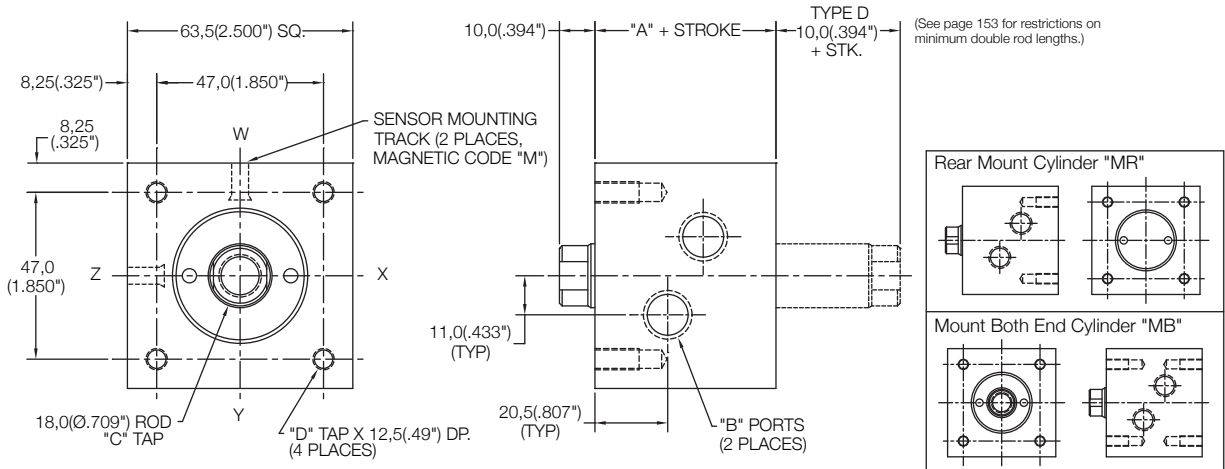

Thru Mount Cylinder "MT"

MODEL	TYPE	STANDARD STROKES	"A"	PISTON AREA
L20	_,D	25mm, 50mm, 75mm, 100mm	51,0(2.01")	PUSH 8,04 cm ² (1.25 in ²) PULL 5,50 cm ² (0.85 in ²)

	Standard Threads	"EM" Option
"B"	G1/4	#4 SAE
"C"	M12X1,75	7/16-20

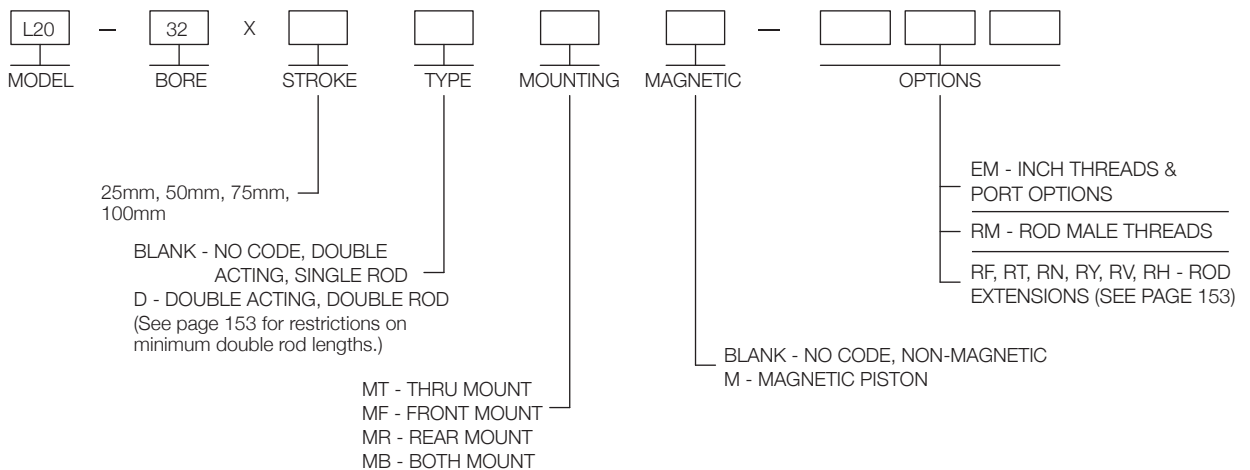
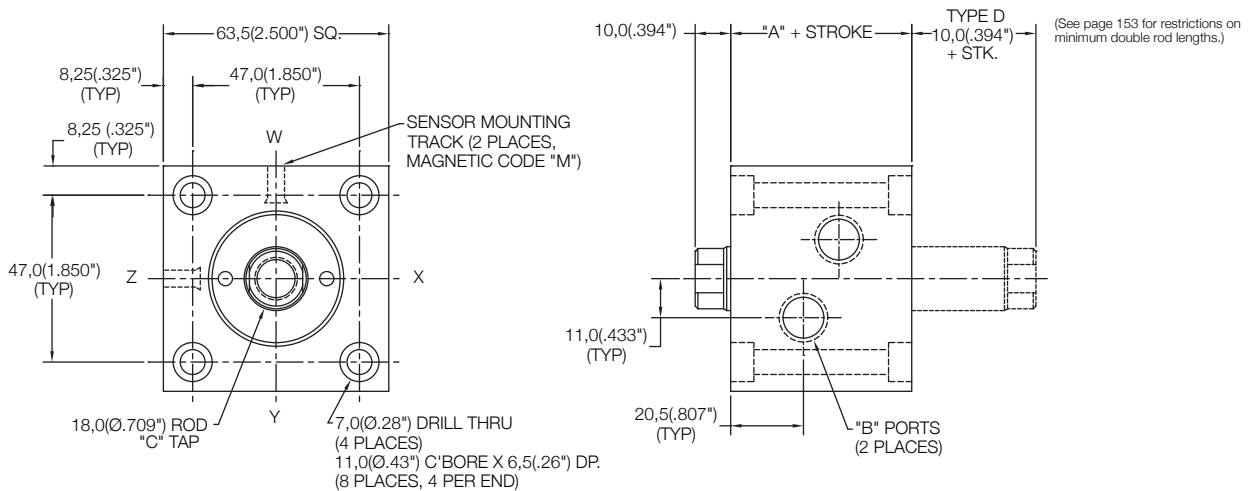

Front Mount Cylinder "MF"

MODEL	TYPE	STANDARD STROKES	"A"	PISTON AREA
L20	_,D	25mm, 50mm, 75mm, 100mm	55,0(2.17")	PUSH 12,57 cm ² (1.95 in ²) PULL 8,77 cm ² (1.36 in ²)

	Standard Threads	"EM" Option
"B"	G1/4	#4 SAE
"C"	M16X2	5/8-18
"D"	M8X1.25	5/16-24

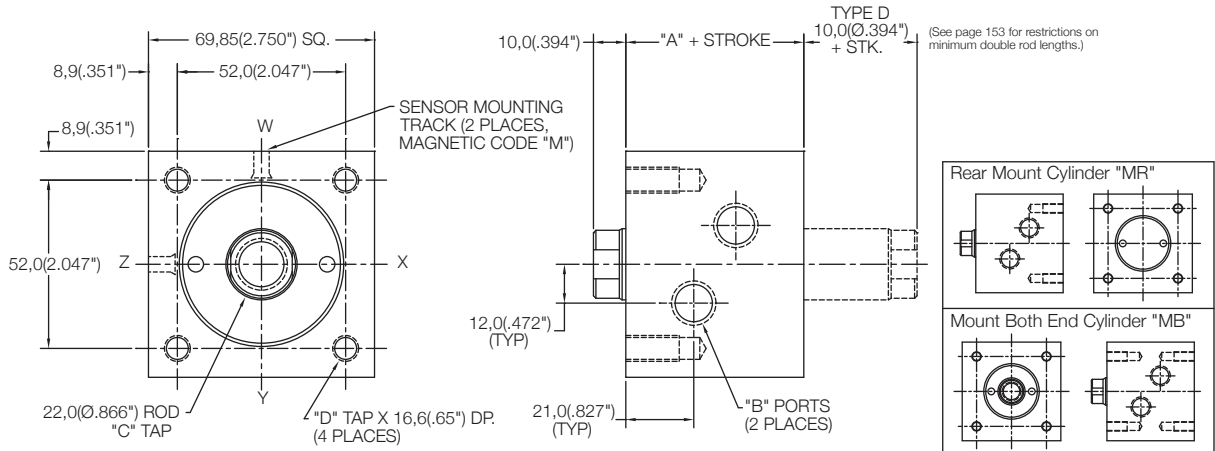

Thru Mount Cylinder "MT"

MODEL	TYPE	STANDARD STROKES	"A"	PISTON AREA
L20	_,D	25mm, 50mm, 75mm, 100mm	55,0(2.17")	PUSH 12,57 cm ² (1.95 in ²) PULL 8,77 cm ² (1.36 in ²)

	Standard Threads	"EM" Option
"B"	G1/4	#4 SAE
"C"	M16X2	5/8-18

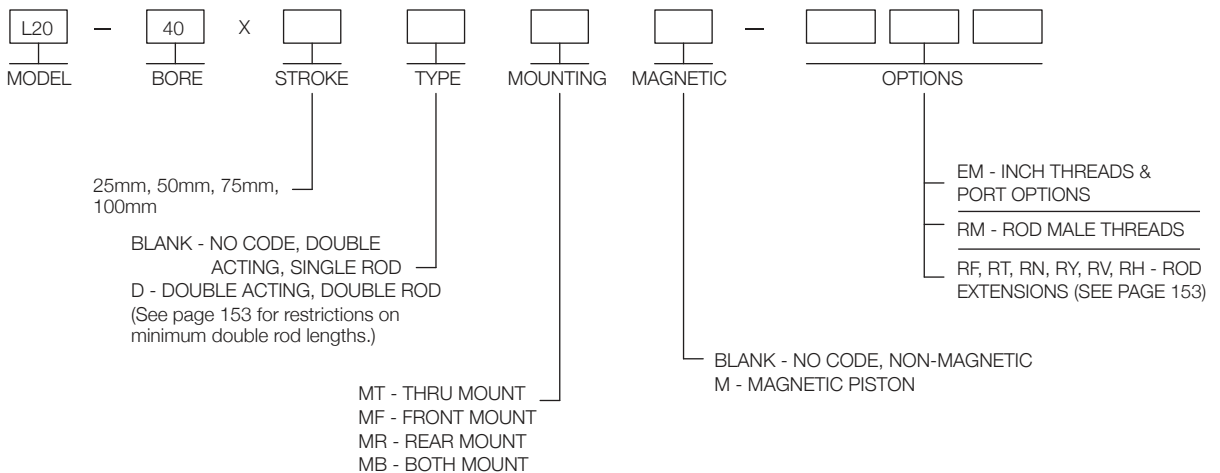
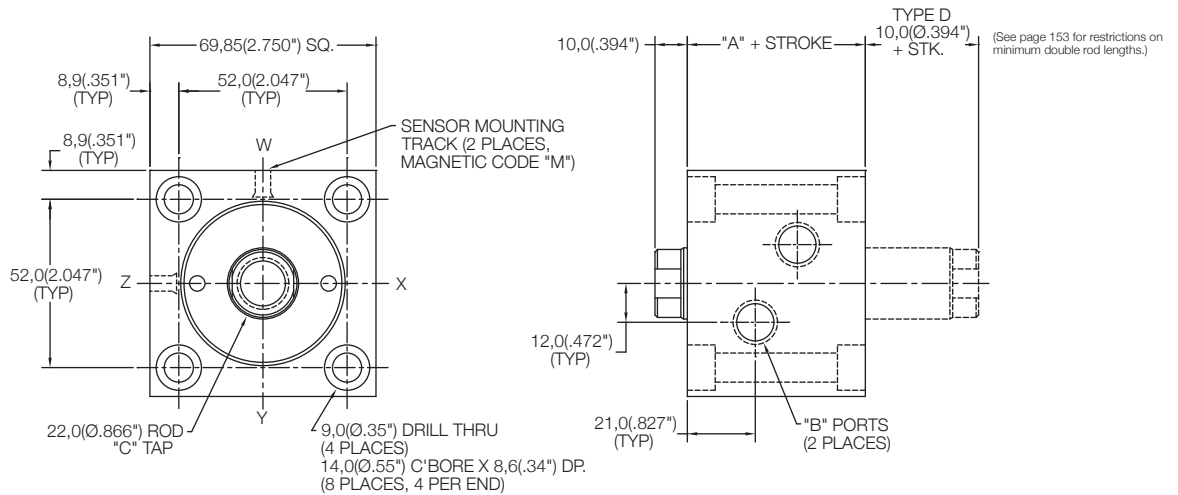

Front Mount Cylinder "MF"

MODEL	TYPE	STANDARD STROKES	"A"	PISTON AREA
L20	_D	25mm, 50mm, 75mm, 100mm	60,0(2.36")	PUSH 19,63 cm ² (3.04 in ²) PULL 13,48 cm ² (2.09 in ²)

	Standard Threads	"EM" Option
"B"	G1/4	#4 SAE
"C"	M20X2.5	3/4-16
"D"	M10X1.5	3/8-24

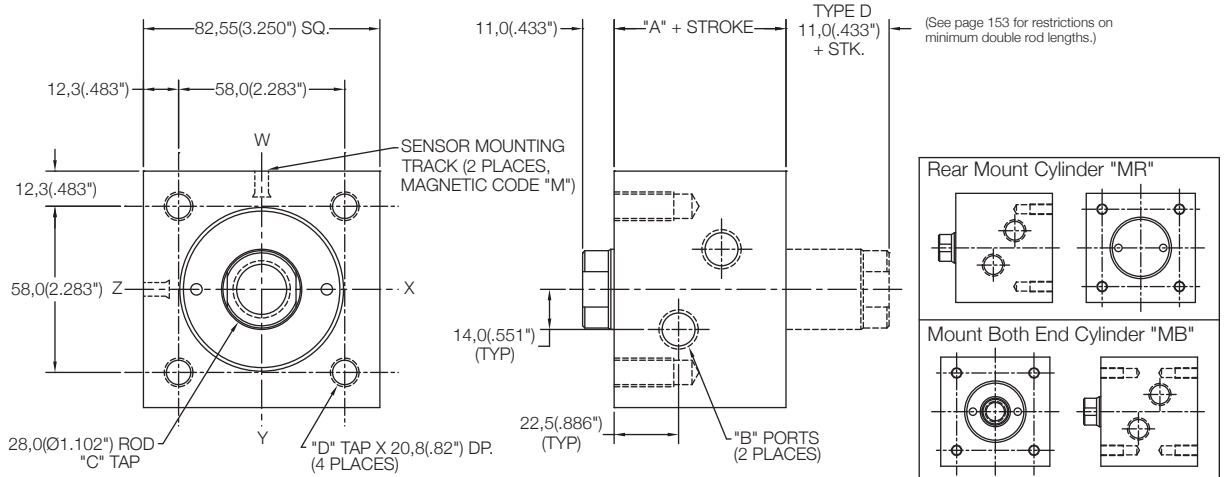

Thru Mount Cylinder "MT"

MODEL	TYPE	STANDARD STROKES	"A"	PISTON AREA
L20	_D	25mm, 50mm, 75mm, 100mm	60,0(2.36")	PUSH 19,63 cm ² (3.04 in ²) PULL 13,48 cm ² (2.09 in ²)

	Standard Threads	"EM" Option
"B"	G1/4	#4 SAE
"C"	M20X2.5	3/4-16

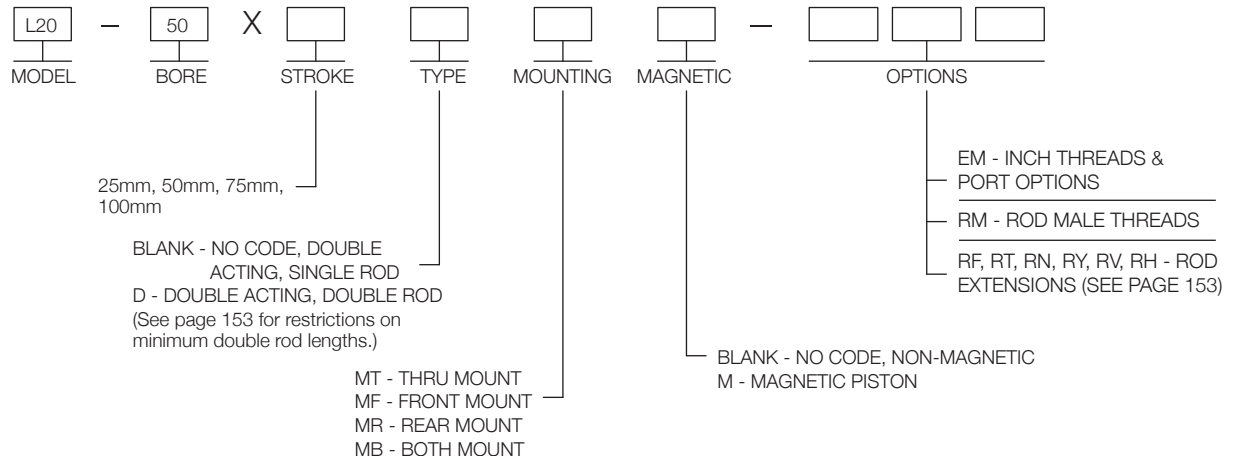
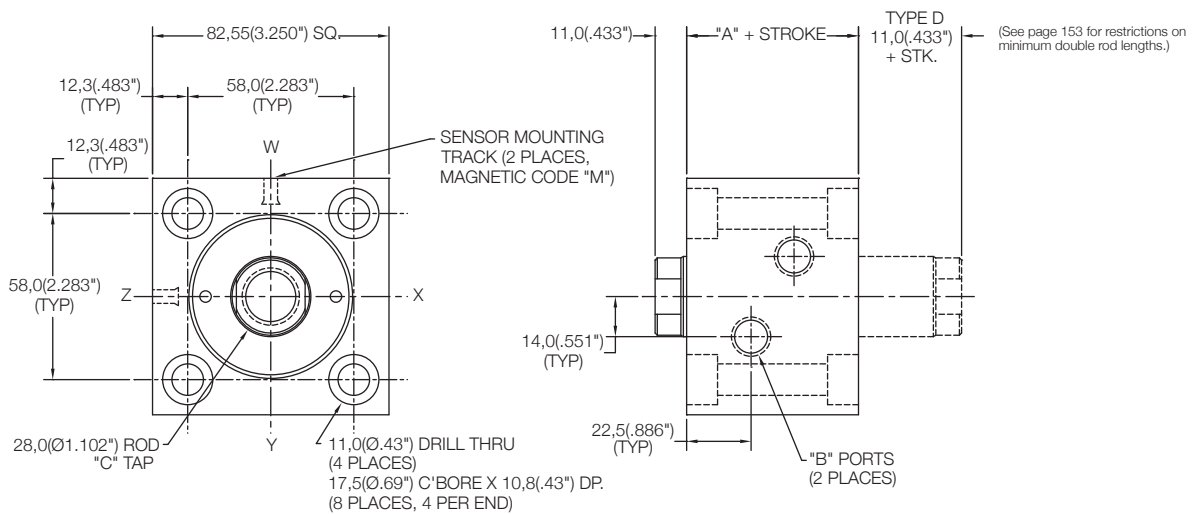

Front Mount Cylinder "MF"

MODEL	TYPE	STANDARD STROKES	"A"	PISTON AREA
L20	_,D	25mm, 50mm, 75mm, 100mm	67,0(2.64")	PUSH 31,17 cm ² (4.83 in ²) PULL 20,99 cm ² (3.25 in ²)

	Standard Threads	"EM" Option
"B"	G1/4	#4 SAE
"C"	M27X3	1-14
"D"	M12X1.75	1/2-20

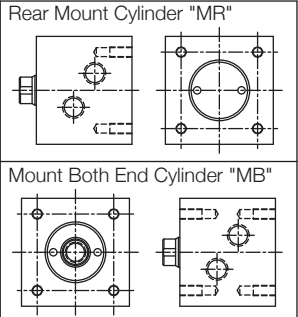
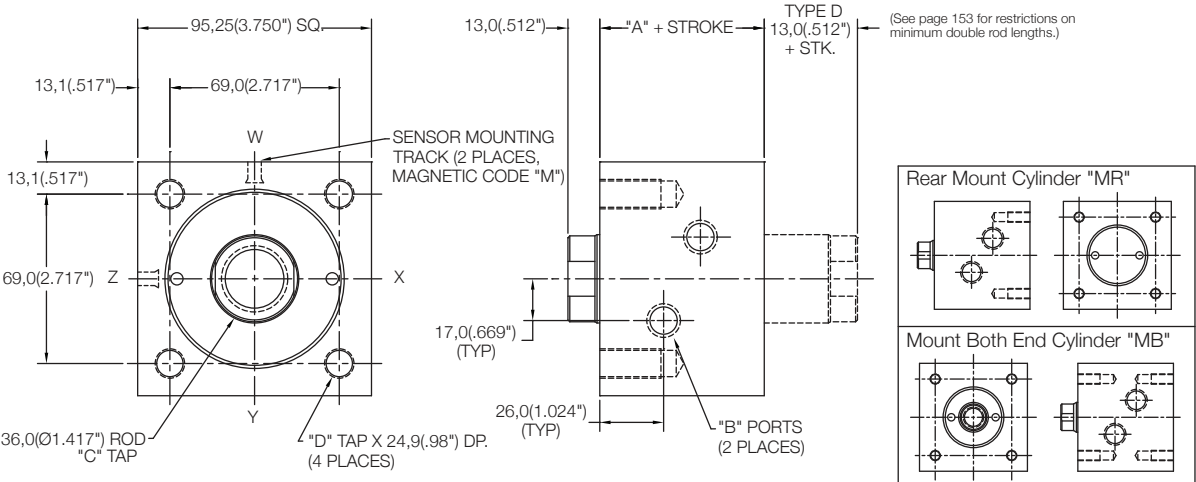

Thru Mount Cylinder "MT"

MODEL	TYPE	STANDARD STROKES	"A"	PISTON AREA
L20	_,D	25mm, 50mm, 75mm, 100mm	67,0(2.64")	PUSH 31,17 cm ² (4.83 in ²) PULL 20,99 cm ² (3.25 in ²)

	Standard Threads	"EM" Option
"B"	G1/4	#4 SAE
"C"	M27X3	1-14

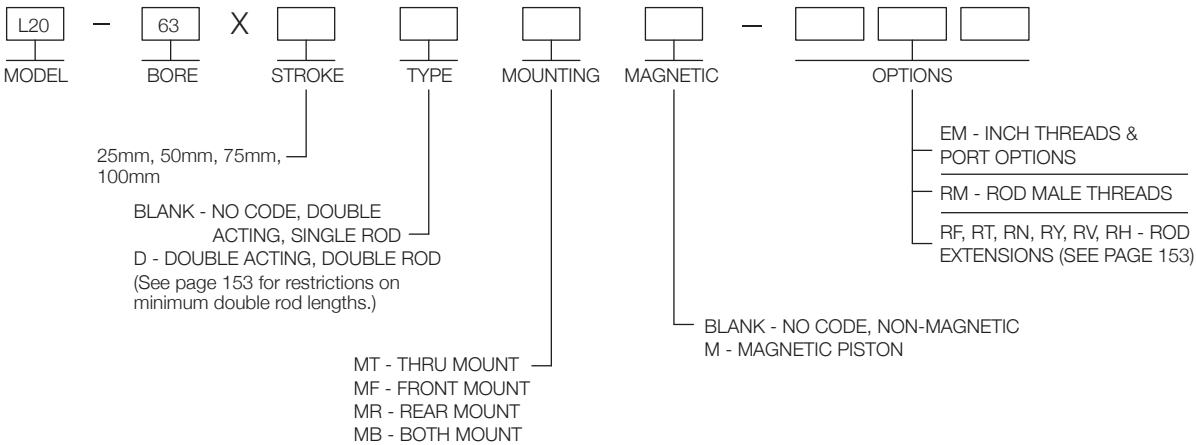
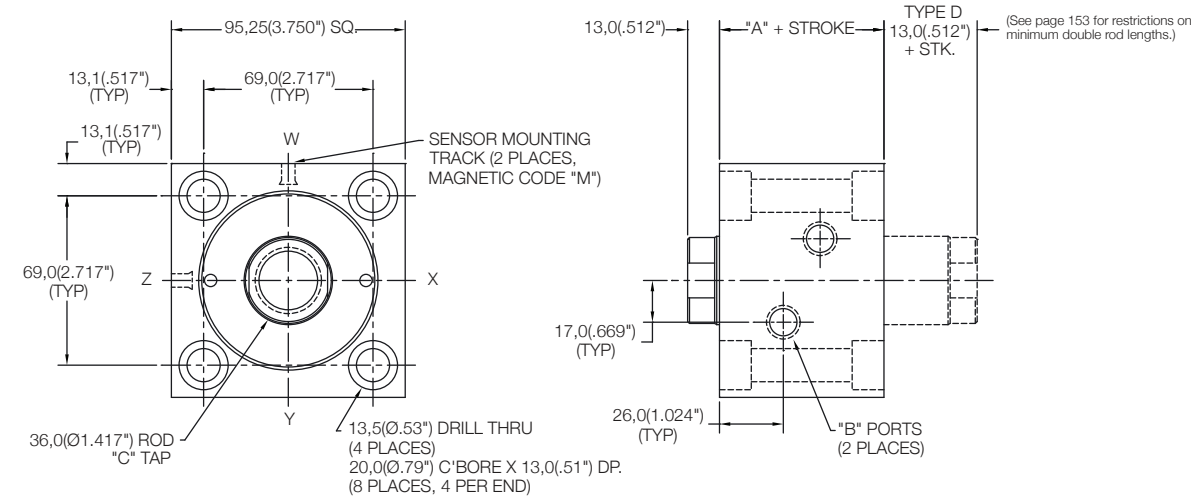

Front Mount Cylinder "MF"

MODEL	TYPE	STANDARD STROKES	"A"	PISTON AREA
L20	_,D	25mm, 50mm, 75mm, 100mm	78,0(3.07")	PUSH 45,60 cm ² (7.07 in ²) PULL 29,70 cm ² (4.60 in ²)

	Standard Threads	"EM" Option
"B"	G3/8	#6 SAE
"C"	M33X3.5	1 1/4-12
"D"	M14X2	5/8-18

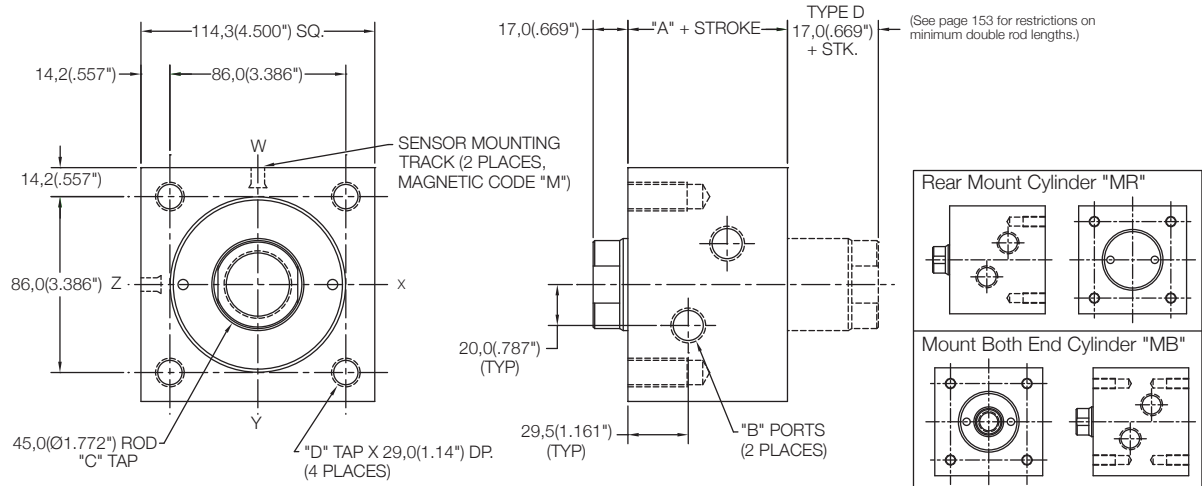

Thru Mount Cylinder "MT"

MODEL	TYPE	STANDARD STROKES	"A"	PISTON AREA
L20	_,D	25mm, 50mm, 75mm, 100mm	78,0(3.07")	PUSH 45,60 cm ² (7.07 in ²) PULL 29,70 cm ² (4.60 in ²)

	Standard Threads	"EM" Option
"B"	G3/8	#6 SAE
"C"	M33X3.5	1 1/4-12

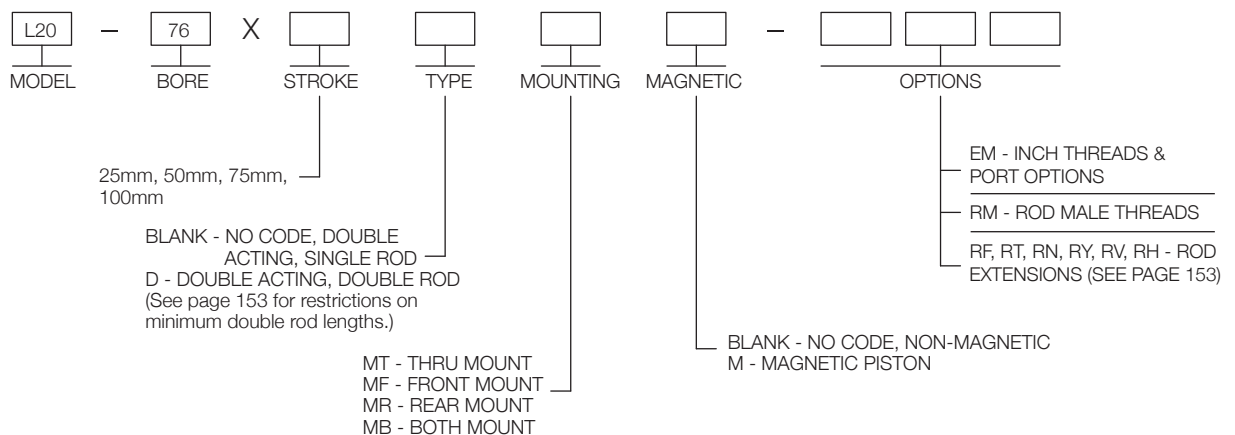
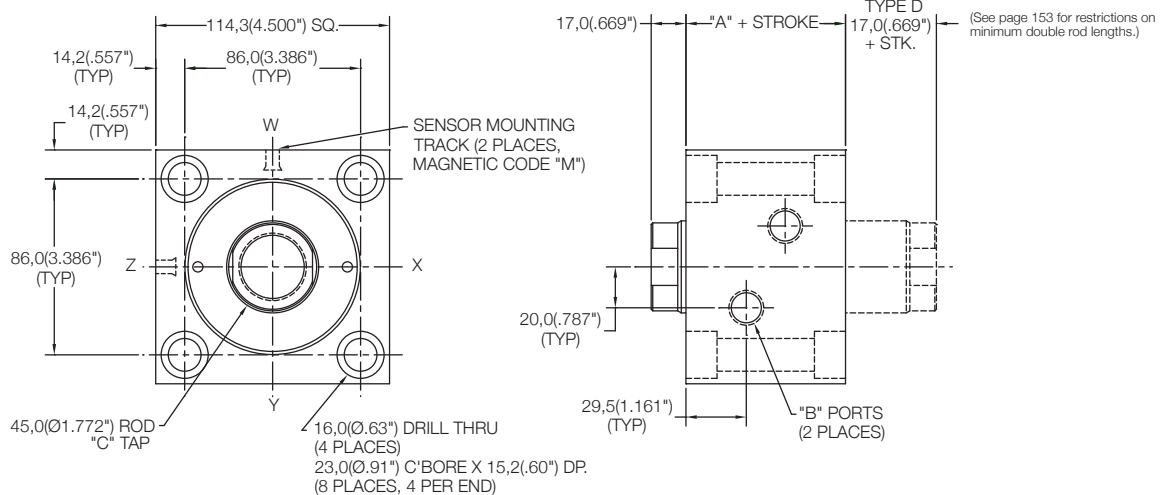

Front Mount Cylinder "MF"

MODEL	TYPE	STANDARD STROKES	"A"	PISTON AREA
L20	_,D	25mm, 50mm, 75mm, 100mm	96,0(3.78")	PUSH 81,07 cm ² (12.57 in ²) PULL 56,44 cm ² (8.75 in ²)

	Standard Threads	"EM" Option
"B"	G3/8	#6 SAE
"C"	M42X4.5	1 1/2-12
"D"	M16X2	5/8-18

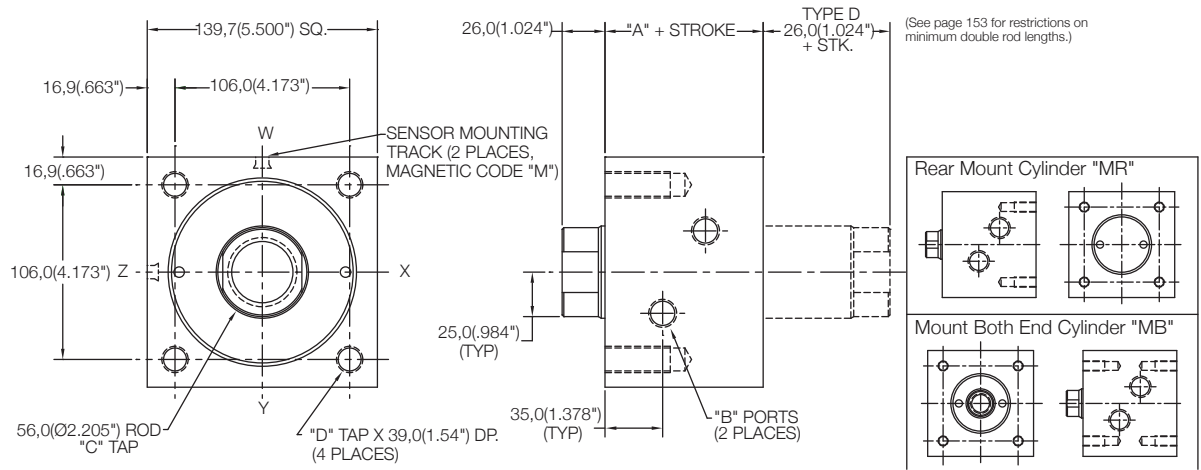

Thru Mount Cylinder "MT"

MODEL	TYPE	STANDARD STROKES	"A"	PISTON AREA
L20	_,D	25mm, 50mm, 75mm, 100mm	96,0(3.78")	PUSH 81,07 cm ² (12.57 in ²) PULL 56,44 cm ² (8.75 in ²)

	Standard Threads	"EM" Option
"B"	G3/8	#6 SAE
"C"	M42X4.5	1 1/2-12

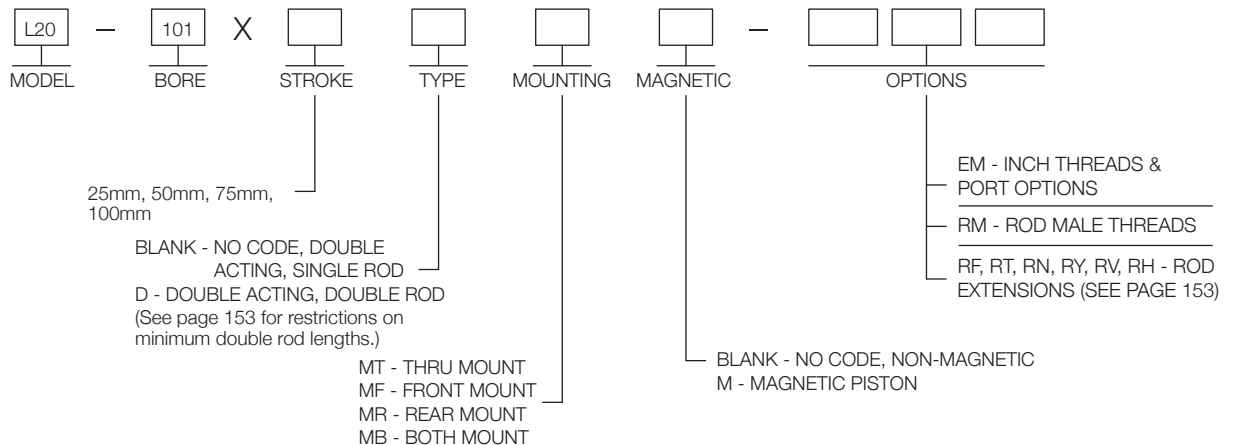
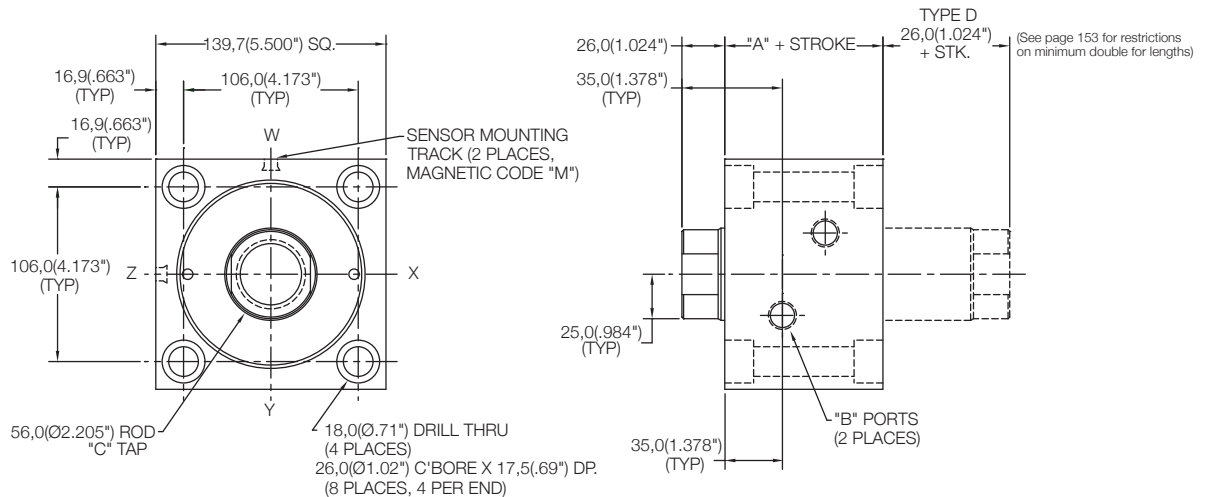

**Male Thread
Option - "RM"**

Bore	"A"	"B"	"EM" Option	"B"
25	M10X1.25	16 (.63")	1/2-20	18 (.71")
32	M12X1.25	18 (.71")	9/16-18	25 (.98")
40	M16X1.5	22 (.87")	3/4-16	30 (1.18")
50	M20X1.5	28 (1.10")	7/8-14	35 (1.38")
63	M27X2	36 (1.42")	1 1/4-12	45 (1.77")
76	M33X2	45 (1.77")	1 1/2-12	56 (2.20")
101	M42X2	56 (2.20")	1 3/4-12	70 (2.76")

Dimensions above are the same for double rod cylinders.

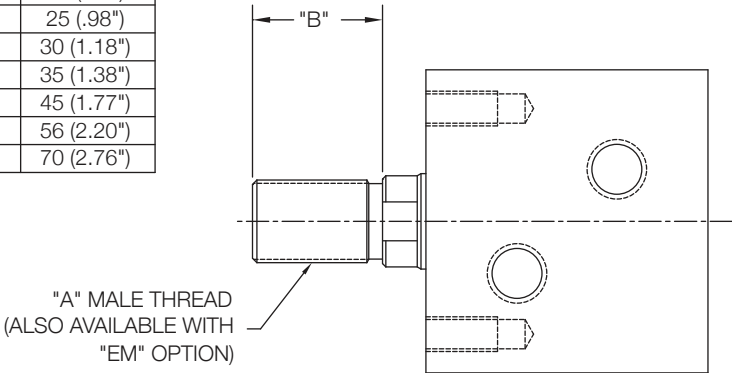

**Rod End Detail
See Chart Below**

Bore	Ø"A"	"B"	"C"
25	13 (.51")	6 (.24")	12 (.47")
32	17 (.67")	8 (.31")	15 (.59")
40	21 (.83")	8 (.31")	19 (.75")
50	27 (1.06")	9 (.35")	24 (.94")
63	35 (1.38")	11 (.43")	32 (1.26")
76	43 (1.69")	13 (.51")	39 (1.54")
101	54 (2.13")	22 (.87")	48 (1.89")

Dimensions above are the same for double rod cylinders.

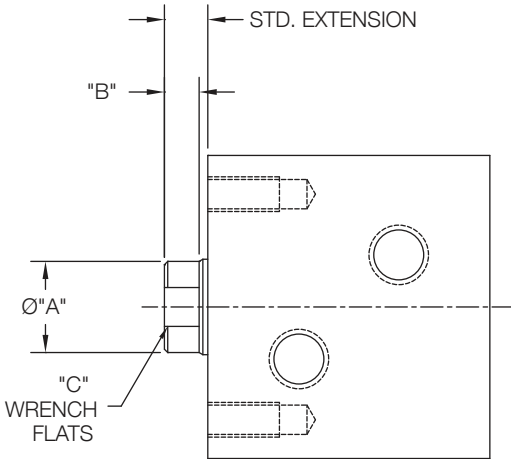

Rod Extensions Option - See Chart Below

Extensions	"RF"	"RT"	"RN"	"RY"	"RV"	"RH"
Length	5 (.20")	10 (.39")	15 (.59")	20 (.79")	25 (.98")	35 (1.38")

For standard extension, see catalog pages.

If cylinder is double ended, extension will be on both ends.

Consult factory for single ended extension on a double ended cylinder.

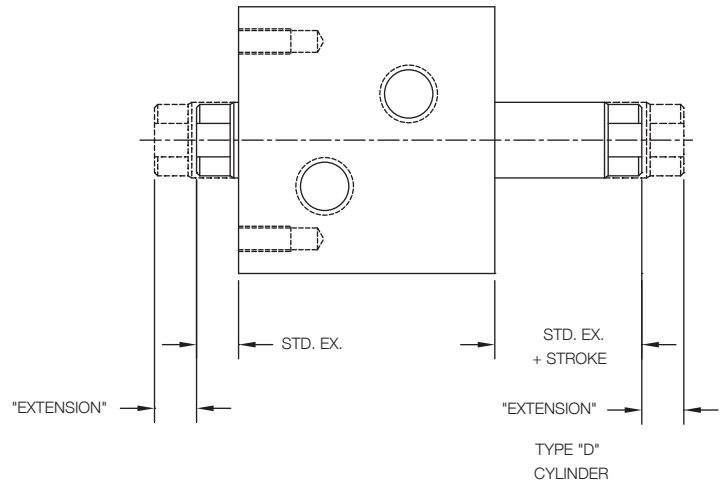

Minimum Rod Extension for Double Rod Option (Type "D") - See Chart Below

Standard double rod cylinders must have "X" dimensions greater than or equal to those listed in the table below. Corresponding rod extensions will be added to cylinders which do not meet this minimum length, so that standard extension plus stroke adds up to "X" MIN. This applies only to rear rod.

Bore	STD. Ex.	"X" MIN	For Strokes Less Than
25	8 (.31")	23 (.91")	15 (.59")
32	10 (.39")	25 (.98")	15 (.59")
40	10 (.39")	30 (1.18")	20 (.79")
50	11 (.43")	31 (1.22")	20 (.79")
63	13 (.51")	38 (1.50")	25 (.98")
76	17 (.67")	42 (1.65")	25 (.98")
101	26 (1.02")	51 (2.00")	25 (.98")

*Single rod cylinders and cylinders with "RM" rod male thread option do not have this restriction.

