

Installation and calibration manual

HBDF – Mk2 Defrost Sensor

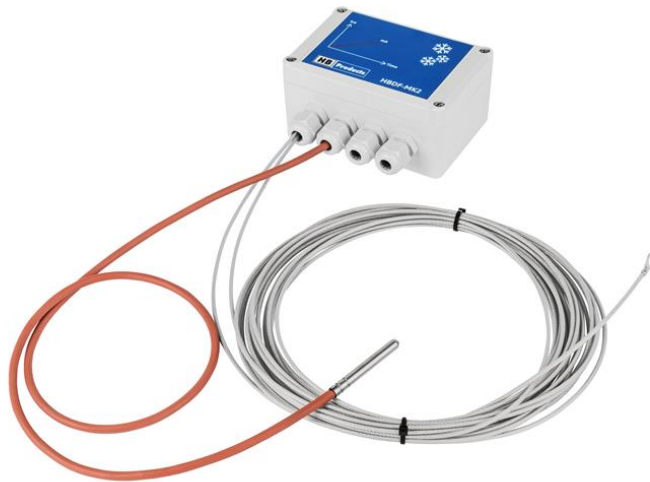

Introduction

The HBDF sensor measures the ice thickness on an evaporator and delivers an analog signal which can be used in a PLC for controlling the defrost. The sensor is suited for cold rooms, blast freezers and cold stores where temperatures are below 0°C. If the sensor is used for heat pumps and similar applications, where the evaporator get wet, special settings are needed. These functionalities are found in the OD (outdoor) version which has both the special settings and a thin measuring wire.

Besides providing input for a PLC, the sensor can also provide other outputs for systems without a classic PLC. The sensor has these three outputs.

- Simple analog: Provide a simple analog signal 4-20 mA linear to the ice thickness for a PLC.
- Smart analog: Provide an analog signal when the specified ice thickness is reached and when defrost can be ended.
- Relay output: In this mode the defrost can be controlled by relays based on parameters in the sensor.

The sensor is equipped with a temperature sensor which detects when the ice is melted and the defrost cycle is complete. This is a smart solution to avoid unnecessary defrost.

The sensor has a M12 interface like other HB-product sensors and is configured by the HB tool. The product consists of a box, a ground cable, the measuring wire, and a temperature sensor.

The sensor is based on the capacitive measurement principle and reacts on ice and water between the wire and the fins in the evaporator. This means the wire must be mounted between fins where ice builds up and the fins must be grounded.

Table of Contents

Introduction 1
 Table of Contents 1
 Safety Instructions 2
 Installation 3
 Installation on overfeed evaporators..... 4
 Installation on DX evaporators 5
 Installation on Heatpumps 6
 Wiring the sensor..... 7
 Sensor sconfiguration 9
 Calibration of sensor..... 12
 LED indication 13
 Fault detection 13
 Sensor Repair 13
 Spare Parts..... 13

Safety Instructions

CAUTION! Always read the operational guidelines before commencing work! Read all warnings Installation of HBDF requires technical knowledge of both refrigeration and electronics. Only qualified personnel should work with the product. The technician must be aware of the consequences of an improperly installed sensor and must be committed to adhering to the applicable local legislation.

If changes are made to type-approved equipment, this type of approval becomes void. The product's input and output, as well as its accessories, may only be connected as shown in this guide. HB Products assumes no responsibility for damages resulting from not adhering to the above.

Explanation of the symbol for safety instructions. In this guide, the symbol below is used to point out important safety instructions for the user. It will always be found in places in the chapters where the information is relevant. The safety instructions and the warnings must always be read and adhered to.

	<p>CAUTION! Refers to a possible limitation of functionality or risk in usage. NOTE! Contains important additional information about the product and provides further tips. The person responsible for operation must commit to adhering to all the legislative requirements, preventing accidents, and doing everything to avoid damage to people and materials.</p>
---	---

Intended use, terms of use. The HBDF defrosting sensor is designed for measuring ice formation on evaporators. If the HBDF is to be used in a different way and if the operation of the product in this function is determined to be problematic, prior approval must be obtained from HB Products.

Defrosting with hot gas must be performed in a safe way to ensure that there is no risk for liquid hammering and leakage of refrigerant.

Preventing collateral damage: Make sure that qualified personnel assess any faults and take necessary precautions before attempting to make replacements or repairs, to avoid collateral damage. Disposal instructions: HBDF is constructed so that the modules can easily be removed and sorted for disposal.

Installation

How to install the electronic box and temperature sensor

Installation of controller box and temperature sensor if used.

- 1) The sensor box is installed on the frame of the evaporator.
- 2) Ground wire should be connected to the frame. We recommend using stainless screw with a star washer/disc and cover/applying silicone grease/compound around the connection to avoid corrosion. It is important that the evaporator fins are connected electrically to ground – it will not work without.
- 3) Normally installed with a standard unshielded cable. If the EMC is higher than described in EN 61326, a shielded cable must be used.
- 4) If possible, look at the evaporator in operation and notice where the ice is formed and where the ice remains during defrost.
- 5) The temperature sensor must be mounted between the fins at the bottom of the evaporator section where the ice remains longest when defrosting. The tip of the temperature element is where the sensor is located – make sure it is far away from the defrost heating source hot gas/electrical element.

Where to install the wire

The built up of ice is very different depending on the type of system and the application. The wire must be between the fins where ice will built-up. It can be on the inlet side, on the outlet side or in the middle of the evaporator.

If you have the overview of where ice is building up, you do not need to wire the complete evaporator if the area wired is where you get ice. If you do not have any idea of where the ice will built-up this is the general rules:

- For direct expansion systems and brine systems: Ice will be formed close to the liquid inlet/expansion valve and typically the area close to the liquid outlet will be free from ice due to superheat. The superheated area is often on the air inlet side, and here the wire should not be installed as no ice built up here.
- For pump circulated system: Most ice will be formed close to the liquid outlet but in general the ice distribution will better that for DX systems.

The wire can be installed on the air inlet side on the outlet side, or it can pass through the evaporator. Again, it depends on the design, and you should follow the liquid pipes depending on the type of system as described above.

How to install the wire

The wire can be fixed to the evaporator using two methods:

1. Going forth and back the pipes.
2. Going through the evaporator

You can choose the method best suited for the evaporator as long as it is installed where ice is formed.

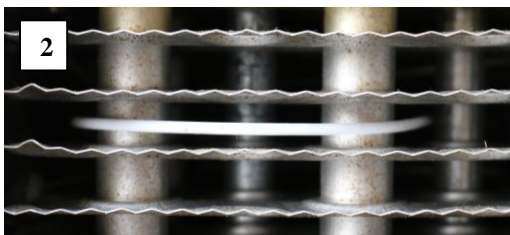

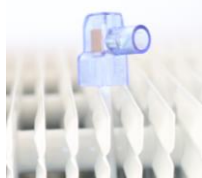

The end of the wire must be taken outside the evaporator. The terminal connector is mounted on the end of the wire to avoid electrical connection between the wire and the fins. The wire insulation should not be removed

The wire is typically mounted on an overfeed evaporator by putting it behind some of the pipes to keep the wire between the fins on the air inlet side. For DX evaporators it might be better to pass the wire through the evaporator

Installation on overfeed evaporators

On the overfeed evaporators the wire is mounted on the air inlet side as the temperature distribution over the evaporator is relatively even.

If ice formation is unknown place the wire all over the inlet side for a flooded evaporator like shown on the drawing. The wire does not need to cover the entire surface as long as it is installed in an area where ice is formed. The distance between the vertical sections of the wire (windings) can be varied from 100 to 1000 mm depending on evaporator size and wire length. When estimating length to be ordered, consider both the vertical sections of the wire and the connecting, horizontal arches.

Note: when calibrating the HBDF, only consider the active, vertical sections of the wire. The wire length is measured in mm. The free end of the wire must end outside the evaporator, and it must be isolated from the evaporator. Use the terminal connector delivered together with the wire.

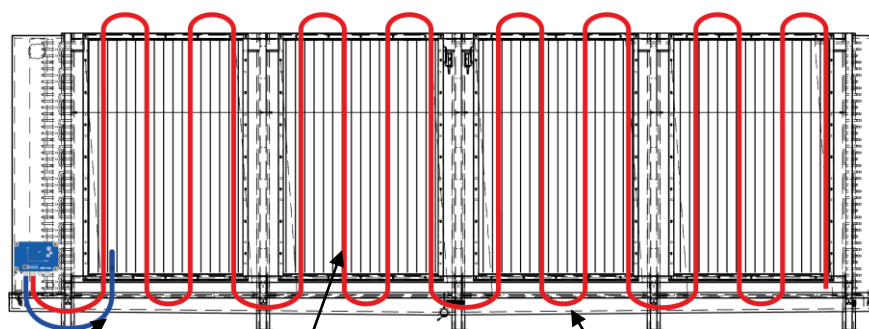
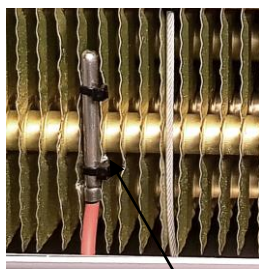

The temperature sensor is installed where the ice remains longest. It must be kept away from hot gas pipes and other defrost devices.

The active part is the vertical sections of the wire placed between fins.

The inactive part where the wire is outside the fins.

Installation on DX evaporators

On DX evaporators ice can built up on both the air inlet side on the outlet side and in the middle. It depends on where the pipes closest to the expansion valve is located. If the superheated pipes are on the air inlet side, it means that there is not enough cooling power to form ice build-up. If possible, observe where ice is formed and place both wires and temperature sensor there.

The sensor wire can be passed in/out through the evaporator from the inlet side to the outlet side as shown below. Alternatively, it can be installed like on an overfeed evaporator if ice built up on the surface

The wire does not need to cover the entire surface as long as it is installed in an area where ice is formed. The distance between the vertical sections of the wire (windings) can be varied from 100 to 1000 mm depending on evaporator size and wire length. When estimating length to be ordered, consider both the vertical sections of the wire and the connecting, horizontal arches.

Note: when calibrating the HBDF, only consider the active sections of the wire where it is between fins. The wire length is measured in mm. The free end of the wire must end outside the evaporator, and it must be isolated from the evaporator. Use the terminal connector delivered together with the wire.



For a DX system ice will built up on the pipes and fins close to the expansion valve. If the superheat pipes on the air inlet side, you can see limited ice built up.



Ice built-up might occur on the air outlet side – but it depends on the evaporator design. Here the pipes closest to the expansion valve are on the air outlet side



For DX evaporators it might be better to pass the wire through the evaporator. If the ice built-up on the surface the wire is installed like on overfeed evaporators by putting it behind some of the pipes to keep the wire between the fins

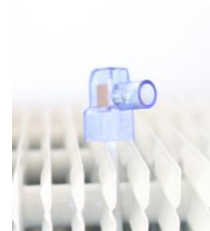

The end of the wire must be taken outside the evaporator. The terminal connector is mounted on the end of the wire to avoid electrical connection between the wire and the fins. The wire insulation should not be removed

Installation on heatpumps

Many heat pumps installed outside suffers from massive icing in the temperature interval from the freezing point to approx. 6°C. Above this temperature the airflow will melt the ice and below the freezing point the moisture content is lower. For operation in the interval from 0 to 6°C the ice will be wet especially on rainy days which means special precautions have to be taken.

The sensor model must be the version suited for heat pumps with a thin measuring wire.
The wire must be secured thoroughly behind the pipes or by using cable ties – especially for horizontal evaporators the ice tends to push the wire out of the evaporator.



Common installation mistakes

The wire is not secured properly

If the wire moves outside the evaporator fin area it does not register any ice and provides a poor detection.

The installation must be redone or secured with cable ties if it is only on a single spot

The insulation on the wire is cut or broken.

If the insulation is cut or broken, you have electrical contact between the fins and the wire. This means the sensor is shorted and does not work.

A new wire is needed as the wire with broken insulation will be sensitive to water and provide unstable detection

The wire is installed where the ice does not occur.

If the wire is installed in the wrong position, you will have either a poor signal or no detection at all.

The wiring must be redone



These pictures show a wire not secured properly on a heat pump with horizontal evaporators. This provide poor detection and a risk of broken insulation when the ice affect the wire.

Wiring the sensor

The HBDF Mk2 use screw terminals and a M12 plug for communication and setup. The sensor needs power connection to be setup and to have the correct function of the relays.

Wiring the HBDF Mk2

When the wire, ground cable and temperature sensor is mounted on the evaporator it is connected in the box. The picture show the inside of the box and it should be straight forward.

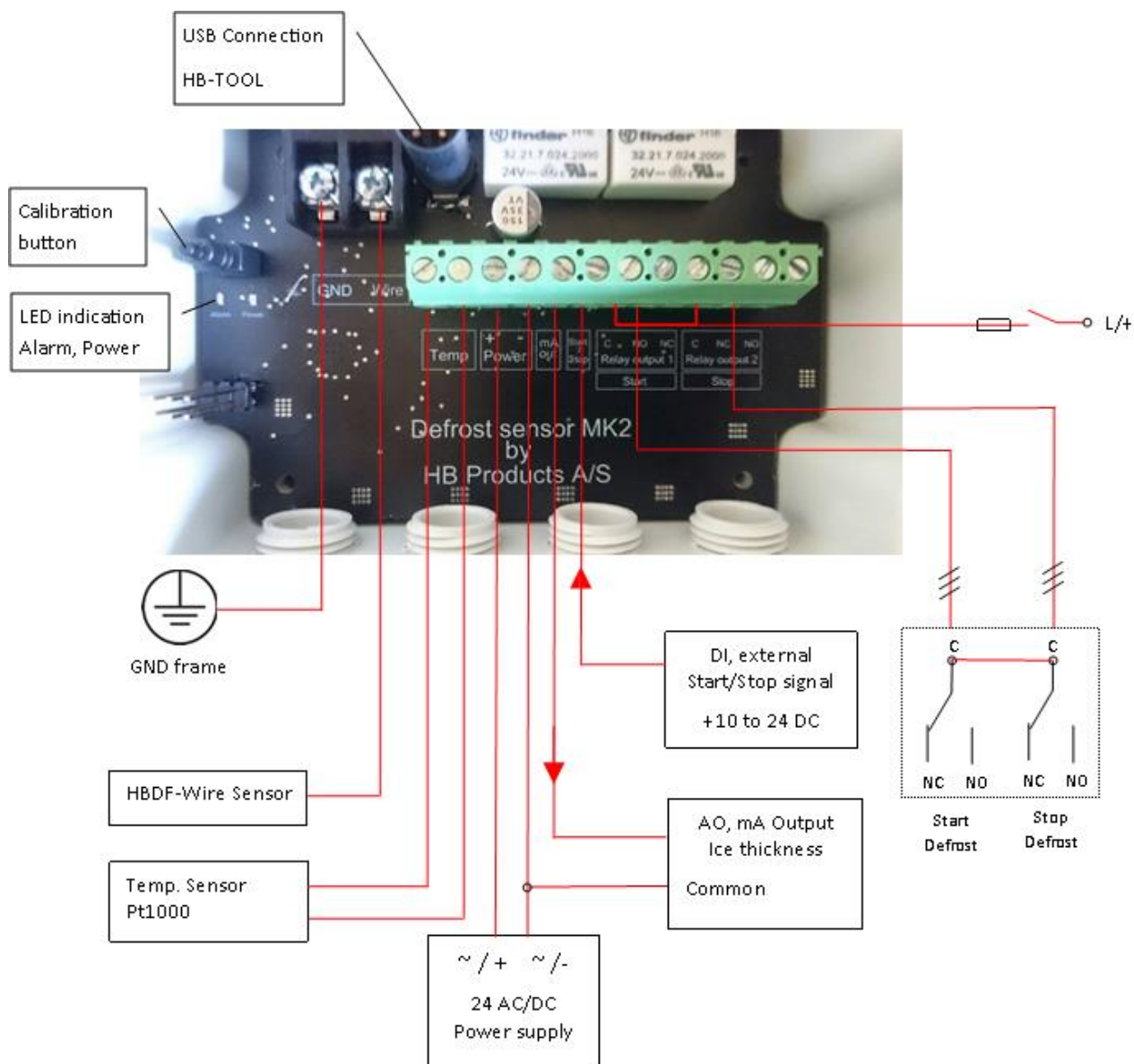

Simple defrost with electric heater.

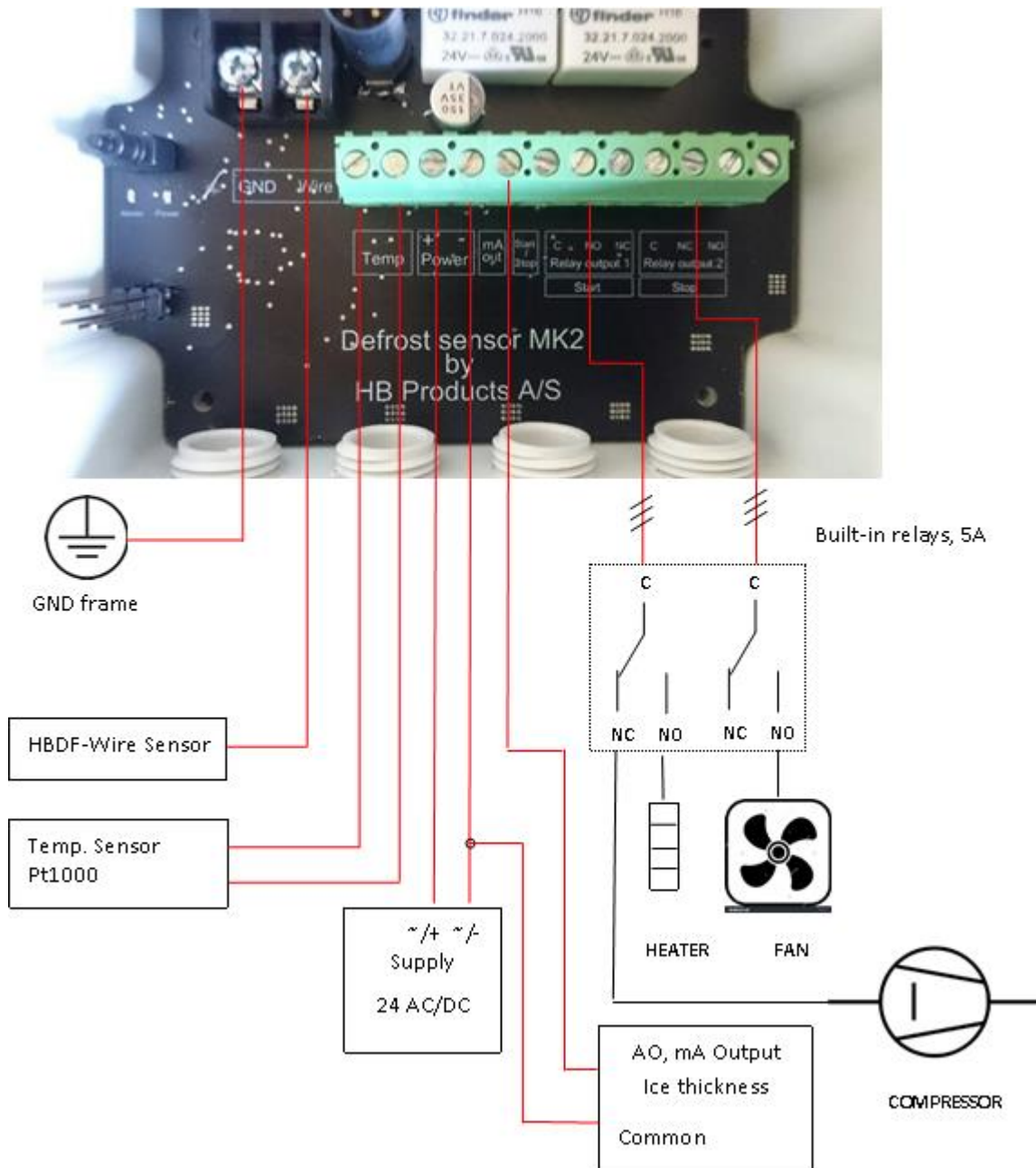

Sensor configuration

All HB-product sensors can be configured using a laptop and a “M12-USB” cable. The software can be downloaded freely on the HB products web page. The configuration data can be stored in the sensor and will be there until erased even without power connection—just like you store data on a memory stick. When you change a value/setting there will be put a check mark next to it and that indicates you have changed something and need to store the data in the sensor.



The sensor has three different operation modes.

The sensor mode is selected in the basic settings.

Simple analog

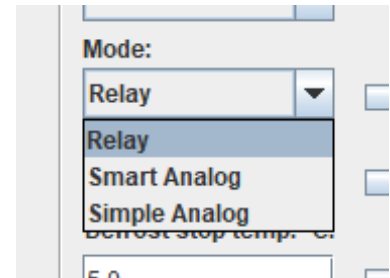

In this mode the sensor provides an analog signal 4-20 mA linear to the ice thickness. The temperature sensor is only used to eliminate measurements when the sensor is wet. The only additional data processing done is an averaging of the output based on the filtering constant.

Parameters used for controlling the output:

- Filter time constant - averaging time in sec
- Disable temp – above this temperature the output will be 4 mA because the measurement is invalid due to water.

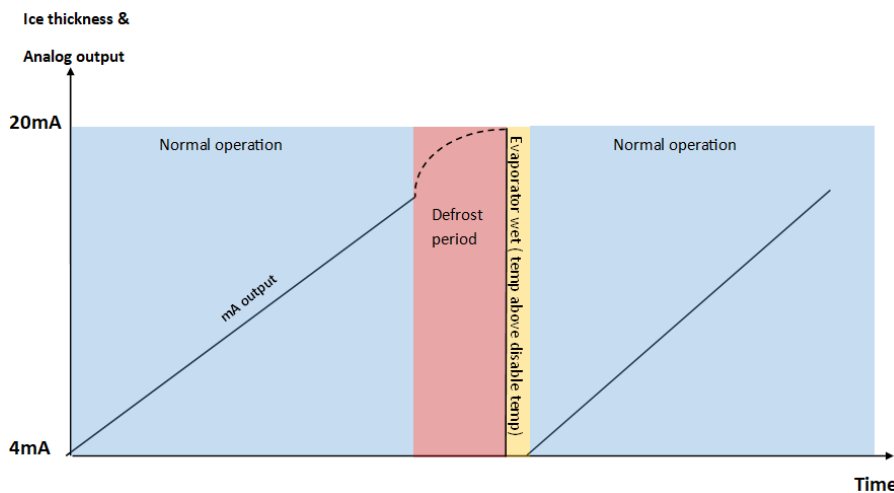

Smart analog

In this mode the sensor provides an analog signal 4-18 mA linear to the ice thickness until the ice thickness is reached. Then the sensor has a constant output of 18 mA until the temperature reach the specified value indicating that the defrosting is done. At this point the output is 19 mA for a period defined by a parameter. When the time has passed the evaporator should be dry and free from ice – ready for a new cycle.

Parameters used for controlling the output:

- Filter time constant - averaging time in sec
- Disable temp – above this temperature the output will be 4 mA, because the measurement is invalid due to water.
- Defrost start in % - defines the ice thickness when defrost should start.
- Defrost stop temp °C - defines the temperature in °C at which the defrosting has ended.
- Sensor delay in min - defines the time in minutes where the sensor is wet and output is 4 mA

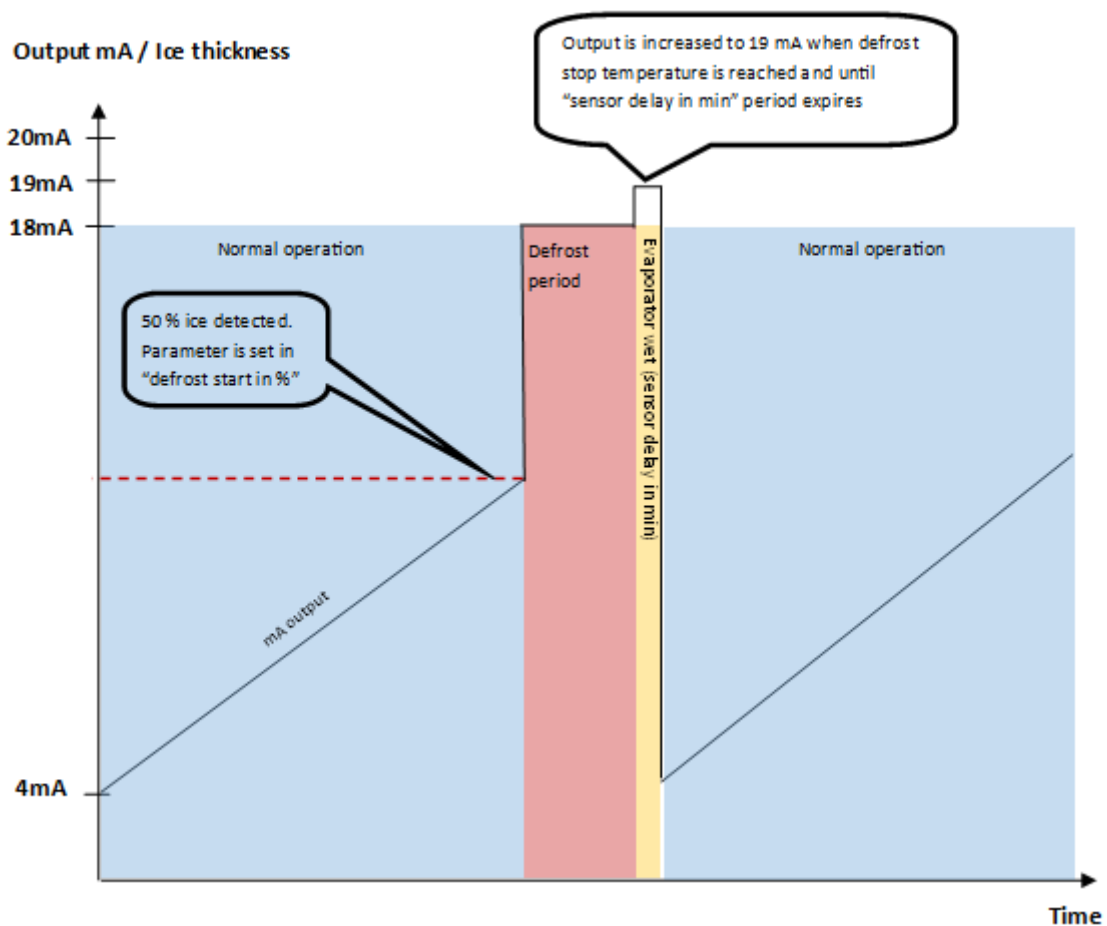

Relay

In this mode the sensor provides both an analog signal 4-20 mA linear to the ice thickness and keep the relays inactive until the ice layer is reached. When the specified ice layer is reached relay1 is activated and it can be used for controlling the defrost/heating and switching of the compressor. Relay1 is activated until the temperature sensor measures the elevated temperature indicating that the defrosting is done. When this temperature is reached Relay1 is deactivated and Relay2 is activated for a period (sensor delay time). This Relay2 can be used for initiating the fan to blow the water out of the evaporator or to prevent the fan from blowing the water out.

During the defrost time and sensor delay time the analog signal is fixed to the mA output determined by the set point (defrost start in %). When the time has passed the evaporator should be dry and free from ice – ready for a new cycle.

Parameters used for controlling the output:

- Filter time constant - averaging time in sec
- Disable temp – above this temperature the output will be 4 mA.
- Defrost start in % - defines the ice thickness when defrost should start.
- Defrost stop temp °C - defines the temperature in °C at which the defrosting has ended.
- Sensor delay in min - defines the time in minutes where the sensor is wet and output is 4 mA

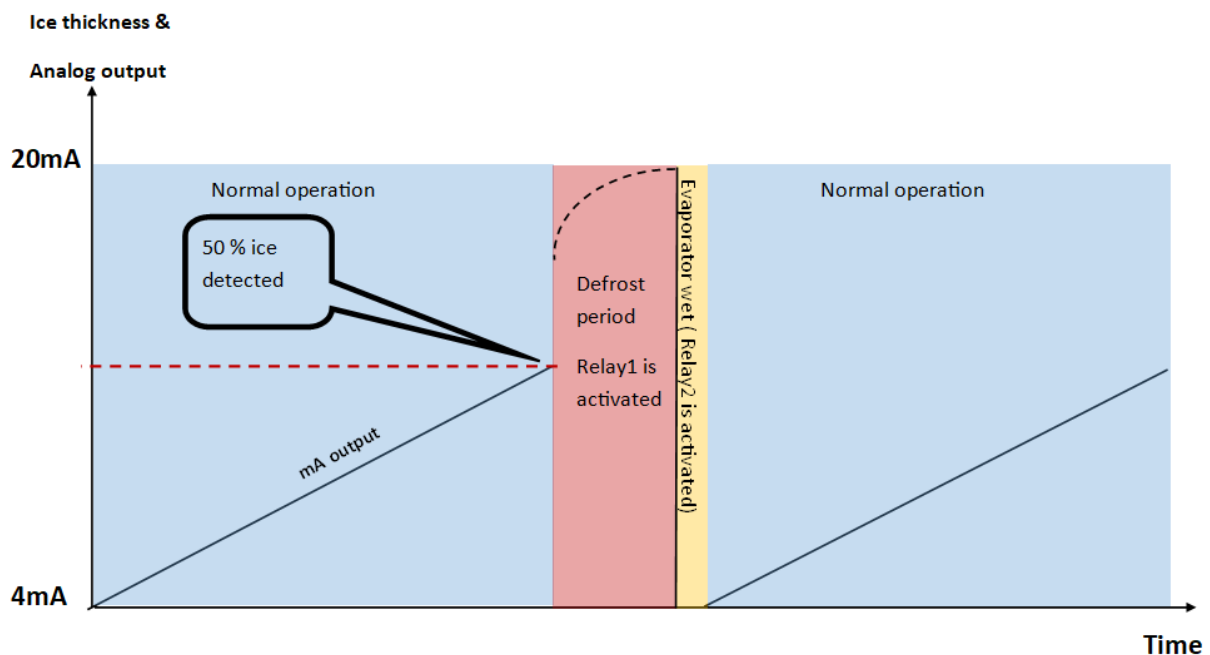

Calibration of the sensor

The sensor can be calibrated using three different methods:

When typing in the active wire length and the distance between the fins the basic calibration is calculated, and the sensor is working, but the accuracy can be improved by making a zero calibration. The calibration is always done when the evaporator is dry and without significant ice

Using the green button in the box

Press the green button until the red LED turn off
Press the green button once and the calibration is done



Using the HB-tool

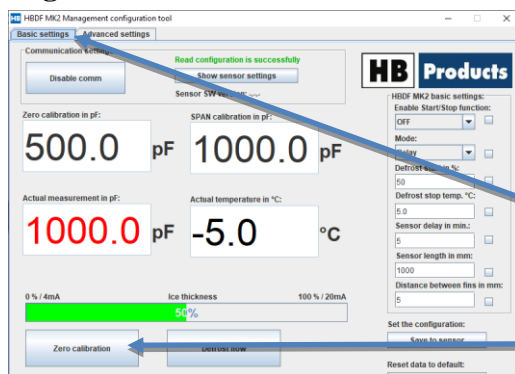

Connect power supply to the box
Connect the HB-tool to the box
Open basic settings tab
Click on the zero-calibration button.

Calibration - when using the thin wire on a heat pump

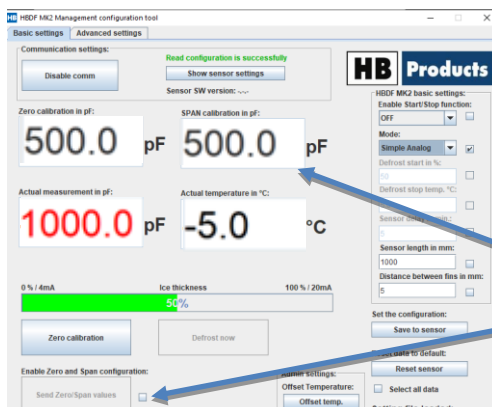

When the sensor is installed and the evaporator is dry and without ice, connect the sensor to the HB-tool using a USB cable.

- Open basic settings tab
- Click on the zero-calibration button.
- Click on the small box at the bottom of the page
- Type in the same value as the zero calibration into the field called "SPAN calibration in pF"
- Click on "Send Zero/Span values"

LED indication

- 1) Green LED, flash indicates power supply, And DI external start signal is ON.
- 2) Red LED indicates Defrost mode or sensor error (Outside measuring range).

LED signal	ON/OFF/Frequency	Functionality
Green	On or flash	Supply voltage connected
	Flash (Run-In mode)	Run-in start signal / operation.
	OFF	No supply voltage
Red	Flash	Defrost mode “start”
	Flash quickly	Defrost mode “stop”
	OFF	Defrost fan/sensor delay (timer end)

Fault Detection

Fault	Reason	Correction of fault
No LED is on / no function	No supply to the sensor or defective cable.	Check for fault in the power supply or replace the supply cable.
Sensor does not provide a useable mA signal and relays does not work	The “Enable start/stop” is set to on and no digital signal is provided	Set the Enable start/stop is set to off if you don’t like to use this function.
Very high actual measurement (Above 4000 pF)	The wire is shorted to the evaporator fins or wire is too long	Make sure the end of the wire is outside the evaporator and use the terminal connector. If that doesn’t solve the problem the wire has to be replaced.
No analog output or Relay contact activation	There may be bad ground connection to the frame.	Clean the metal surface and protect it with special compound/grease.

Practical measurement of output signals: 4-20 mA signal: Function and stability of the 4-20 mA signal can be checked by connecting a hand-held multimeter. If the supply is connected and the power LED flashes and there is no output signal, the electronics may be defective.

Sensor Repair

In case of defects with the sensor, it will typically only be necessary to replace the electrical part.



Note! All terminals are protected against improper termination for a supply voltage up to 40 V. If the supply voltage is higher than 40 V, the electronics will be damaged.

Complaints are processed by HB Products’ dealers/distributors.
Please consider their complaint procedures before returning the sensor.

Spareparts

Position	Designation	Specification	Product number
1	Mechanical part	10 m wire	HBDF-MEK-10M
	Mechanical part	20 m wire	HBDF-MEK-20M
	Mechanical part	30 m wire	HBDF-MEK-30M
2	Electronic part	PCB	HBDF-MK2-EL
3	Temp. sensor	Pt1000-Cable type	HBPT-Pt1000 cable
4	Communication cable	HB USB cable	HBxC-USB