



DTM Series Distributed Transmitter Monitor Introduction

Fully Digital

The DTM series digital transmitter monitor is PVTVM's vibration monitor, vibration transmitter and vibration switch all rolled into one package. Each DTM module can be operated independently or networked together to create a machine protection system. It has all the functionalities of an API 670 multi-channel monitor plus a unique field linearization feature which enables the use of any manufacturers' probe and extension cable combination. DTM modules are fully programmable, flexible, and highly reliable.

Fully Programmable and Flexible

The DTM is modular in nature and can easily be expanded into a larger vibration system with the addition of a:

DTM10 (Proximity Probe Sensor Module)

DTM 20 (Case Vibration Sensors Module)

DTM 96 (Communication Module)

DTM- CFG (Configuration Software)

DTM10 is a proximity probe sensor module which provides measurements in radial vibration, axial position(thrust), and speed / phase reference. The DTM10 works with any proximity probe system combination (including other manufacturers) and can be used:

- With or without Probe Driver
- In any combination of probe and extension cable. The DTM10 has a field linearization feature which enables the DTM10 to interface to any proximity probe system. This feature greatly reduces the requirement for spare parts.
- Works with any shaft material (Steel, Tungsten, K-monel and more).

DTM20 is a case mounted seismic sensor module which provides case vibration measurements in acceleration, velocity, or displacement. The DTM20 works with any case mounted sensor (including other manufacturers):

- Accelerometers
- Velocity Transducers

DTM96 is a communication module that can be used to network up to (32) DTMs together to form a vibration protection system. The DTM96 can be used to communicate directly with control systems (PLC or DCS) via modbus to provide data from the DTMs such as: alarm status, system status, overall value, and more.

DTM-CFG is the software used to configure the DTM modules (DTM10 and DTM20) either with a local laptop computer or a remote computer on the network (requires Modbus connection).

Configurable Parameters:

- Measurement Type (Case Vibration, Radial Vibration, Axial Position, and Speed/Phase)
- Sensor Type and Sensitivity (Proximity Probe, Accelerometer and Velocity Transducer)
- Full Scale Range (g, ips, mm/s, rms, pk, etc..)
- Time Delays
- Alarm Set Points

Observe:

- Alarm and Channel OK Status
- Trip Multiply
- Bypass and Overall Vibration Level

Control:

- Trip Multiply values
- Bypass and Reset functions

Note: The DTM can be pre-configured at the factory. DTM-CFG software is only required when field configuration is desired.

Highly Reliable System

The DTM was designed to be used for critical machines as well as balance of plant applications. Built into every DTM is a system redundancy based upon a reliable microprocessor and proprietary system diagnostics which all contribute to a robust system design which will maximize system uptime.

Power Redundancy- The DTM module has redundant power supply inputs to maximize the reliability of the system. A single power supply failure will not affect the operation of the system.

Output Redundancy- The DTM module is equipped with redundant 4-20mA outputs, redundant relay outputs, and a Modbus communication port. The DTM relay outputs can be configured for any logic configuration required.

Channel Redundancy- The DTM can be configured for triple redundancy with multiple DTMs networked together.

System Diagnostics- The DTM performs internal diagnostic tests to search for errors: sensor status, supply voltage, system power up, fieldbus status and more. If there is an error, the system OK status LED on the DTM will go off, and an error will be registered for the channel and sent via Modbus.

Reliable Microprocessor- critical data and system configuration is stored in a solid-state memory chip. The memory chips are designed not to lose data during an interruption of power. Once power is restored, the critical data and system configuration are recovered from the memory chips.

Additional Features

Power-Up Inhibit- This feature decreases false alarms due to higher vibration levels during machine start-up.

Condition Monitoring- Each DTM module has a buffered output for easy connection to a condition monitoring system or other vibration analysis hardware.





Selection Guide of DTM Modules

Model Number	DTM10	DTM20	DTM96	DTM-CFG
	Radial Shaft Vibration, Thrust & Speed	Case Vibration	Accessory: Communication Module	Accessory: Configuration Software
Available as Pre- Configured or Field Programmable *1	•	•		•
Vibration Measurements				
Radial Vibration	•			
Axial Position	•			
Speed/ Phase Reference	•			
Case Vibration		•		
Sensor Interfaces				
Accelerometer		•		
Velocity Transducer		•		
Proximity Probe	•			
Works With or Without Probe Driver	•			
Outputs/ Communications				
Redundant 4-20mA Output	•	•		
Relay Output	•	•		
Redundant Power Supply Input	•	•		
Modbus Output	•	•	• (isolation)	
Buffered Output	•	•		
Features				
Push Button Setup (Limited Settings)	•	•		
Power-Up Inhibit	•	•		
System OK Checking	•	•		
Hazardous Rating (CSA, ATEX, **TR CU) II 3 G Ex nA II T4 Class I, Div.2; Grps A, B, C & D, T4 2Ex nA II T4 X	•	•	•	
Network DTMs via Modbus *2	•	•	•	
Warranty- 5 years	•	•	•	

• = Complete Offering, S= Single 4-20mA Output or power supply input

Notes:

*1 = Field programming requires DTM-CFG-K Configuration Software kit. Without the software, the DTMs can only be configured for alarm set points and ZERO adjustment.

*2 =To network up to 32 DTMs via Modbus, requires (1) DTM96 Communication Module

** TR CU certificate is pending

Looseness Monitor DTM20-A4

The DTM20-A4 is designed for monitoring reciprocating compressors & engines. It is a multiple parameter monitor with both impact monitoring and acceleration monitoring. Alarm can be the combination of these two parameters. You can conveniently decide the alarm level of each of the monitored parameters and setup accordingly. In addition to analog transmission, the monitor also supplies a digital output, dual alarms, and a condition monitoring. Thus greatly enhanced the analysis and monitoring capabilities of the system. The looseness monitor conforms to ISO10816-6.

Looseness Monitor Unique Features

Precision Looseness Monitor

Programmable impact trigger level and time base.
Impact is set in acceleration (g's) with DTM-Config software.

Highly repeatable with quantitative measurement

Multiple parameters monitoring

Not only monitoring looseness impact but also overall acceleration

Both parameters can be monitored and alarmed

Multiple outputs

Analog transmission via dual 4-20mA



Digital Modbus RTU output

Dual programmable alarms

Waveform and spectrum (with software)

More accurate impact response

Industrial, light weight accelerometer (100mv/g -pk constant current) makes the measurement more responsive to high frequency and repeatable

Live waveform helps trigger level setting

Within the configuration process, the live waveform can be analyzed to decide the looseness trigger level thus minimize the "estimated" uncertainty

Designed with reliability

Redundant power supplies

Redundant 4-20mA outputs

Dual dry-contact relay outputs

Trip multiply and Bypass

Galvanic/optical isolation for solid signal processing

Power input isolation

Sensor signal conditioning isolation

Transmission 4-20mA output isolation

Relay output isolation

Digital output isolation with DTM96

Fully field programmable by CFG software

DTM20-CFG can easily change any configuration of the monitor.

Calibration of the system is available with CFG software

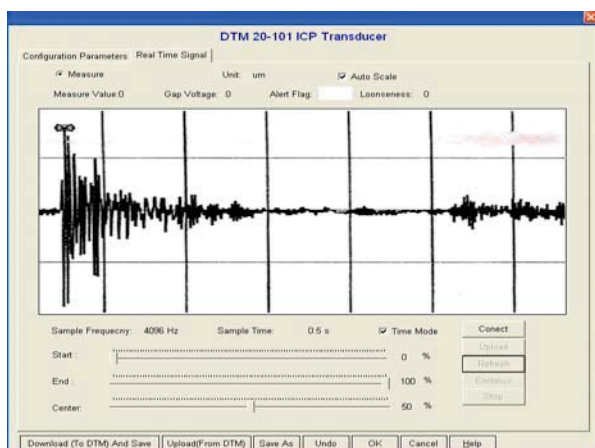



Reciprocating condition monitoring by direct digital connection

Static registers (trend, overall, alarms, GAP, system OK)
Dynamic signal (waveform, spectrum, phase reference, waterfall)

Data will be directly transferred into server with no needs of additional interface hardware

MODBUS digital communication

Build-in Modbus RTU digital communication
More register information from Modbus

Specifications

Electrical

Power:

Redundant. Accept dual power input
20-30VDC @150mA
Galvanic isolation: 1000VDC

Frequency Response:

100~1200rpm

Piezo Sensor Interface:

Sensitivity:

100mV/g -pk

Current Source

Nominal : 4mA@24VDC

Monitor Accuracy:

Typical +/-2% FS
Maximum +/-5% FS

Buffered Output:

Original vibration, un-filtered
Impedance: 150Ω
Maximum cable distance: 300m (1000ft)
Sensitivity: same as the sensor
Local BNC connector
On line CM terminals

Overall Vibration output:

Up to two 4-20mA outputs
4-20mA(1):
Source.
Sharing sensor ground
Maximum load resistance 500Ω

4-20mA(2):

Loop. Loop powered by controller.
Optical isolation, 1000VDC
Power supply range: 16-30VDC
Maximum load resistance: 50*(Vs-16)
Where Vs is the loop power supply

Alarm Set Point:

5 ~ 100% FS

Accuracy:

±0.1%.

Delay: 1~60s, according to 1 second increase, default is 3s.

Relays:

Seal: Epoxy.
Capacity: 0.2A/240VAC,
0.4A/110VAC
2.0A/24VDC, resistive load
Relay type: SPTD
Isolation: 1000VDC

Push Buttons:

SET: System on-site calibration and alarm setting
+ : Adjustment increment
- : Adjustment decrement

LED Machine Condition Indicator:

OK: System OK indication
ALT: Vibration over Alert level
DNG: Vibration over Danger level
BYP: System in BYPASS
TRX: Digital transmission active

RESET/BYPASS:

- Front panel push-button
- Remote RESET/BYPASS terminals

Trip-Multiply

Double or Triple Multiply set by DTM-CFG. This feature is not available with (M2,M4 and M6)

Modbus RTU

RS485 Modbus RTU (with DTM96 for isolation)

Software programming (DTM-CFG):

- Alert and danger set-point, time delay
- ZERO and Full-Scale calibration
- Alarm latching/ non-latching, energized/ de-energized
- Relay programmable with alert, danger or system OK
- Sensor selection, sensitivity setup
- System calibration
- Digital communication setup
- Trip-multiply setup
- Real-time bar-graph and alarms
- 3 layers of password protection

Digital Condition Monitoring

- Terminals
 - RS485 for both Modbus RTU and condition monitoring
- Software PCM360-LT
 - Work with PCM360-LT plant condition management software
 - Dynamic waveform:
 - Real-time vibration data, 2000 sets per data acquisition.
- Alarms:
 - Up to 100 alarms can be stored in DTM20.
- Trend:
 - Up to 1000 trend data can be stored in DTM20.
- Spectrum:
 - Up to 800 lines of resolution.

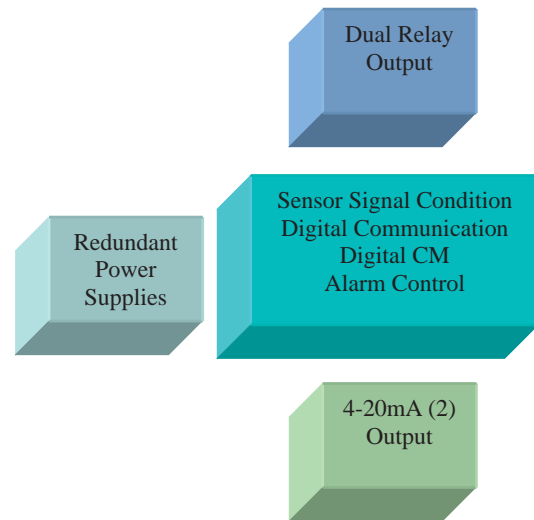

*Building Block of DTM20
All modules are isolated
Digital output isolation via DTM96*

Physical

Dimension:

Height: 75mm (2.95")
see figure below

Weight: 0.9lb (0.4kg)

Environmental

Temperature:

Operation: -40°C ~ +85°C.
Storage: -50°C ~ +100°C.

Humidity: 90% non-condensing.

Case: Aluminum cast (copper free)

Certification

CE certified with EMI compliance

CSA: Class I, Div. 2, Grps A,B,C&D,T4

ATEX: II 3 G Ex nA II T4

**TR CU: 2Ex nA II T4 X

№ TC RU C- US.ГБ05.B.00476

NANIO CCVE



DTM Distributed Transmitter Monitor

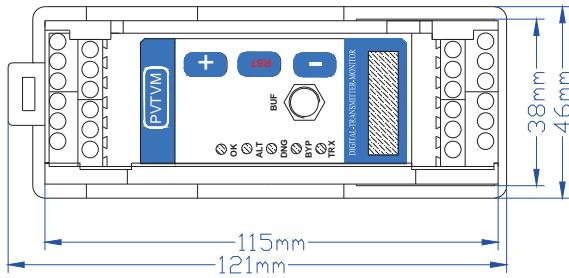

Rail Mounting

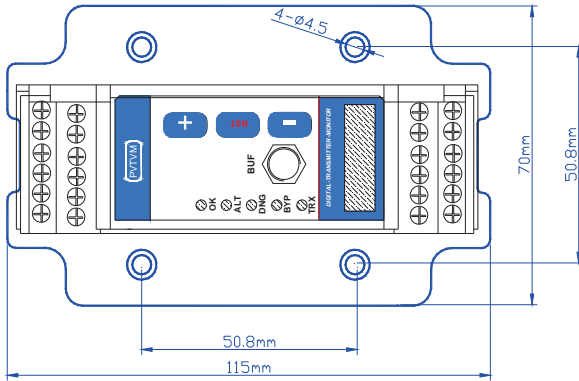
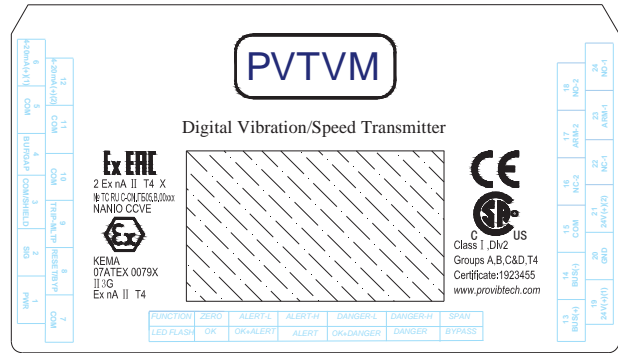

Plate Mounting



Hazardous area

Marking:

ATEX Standards:

EN 60079-0

EN 60079-15

Special condition in hazardous area:

- The ambient temperature range is: $-40^{\circ}\text{C} \leq T_a \leq 70^{\circ}\text{C}$
- DTMs must be placed inside an enclosure that is in accordance with EN 60079-15:2005.
- Provisions must be made externally to prevent the rated voltage from being exceeded by transient disturbances of more than 40 %.



Ordering Information

DTM20-A4-B0-I2-MX-SX-TXXX

Looseness monitor, fully field configurable, with Modbus RTU.

MX: Condition Monitoring,

4-20mA with Optical Isolation*

M5*: Dual 4-20mA, no Condition monitoring

M6: Dual 4-20mA, with Condition monitoring

SX: Approvals.

S0*: CE

S1: CE

CSA: Class I, Div. 2, Grps A,B,C&D,T4

ATEX: II 3 G Ex nA II T4

**TR CU: 2Ex nA II T4X

№ TC RU C- US.ГБ05.B.00476

NANIO CCVE

TXXX: Running Speed

XXX: Running at XXX rpm

* Isolated 4-20mA requires external loop power.

Optional Accessories

DTM-CFG-K

The DTM configuration and calibration software kit includes:

- ✓ DTM-CFG configuration and calibration software CD
- ✓ RS485-USB converter with cable

PCM-TCP

Modbus RTU-TCP Converter

TM900A

Din Rail Mounted Power Supply. Converts 100-240VAC into 24VDC and is capable of powering up to five DTM modules.

Seismic Sensor Systems

- ✓ **TM0782A-K-M**: Accelerometer kit
- ✓ **TM0783A-K-M**: Accelerometer with cable
- ✓ **TM0793V-K-M**: Velocity sensor kit
- ✓ **TM079VD-V/H-K**: Low frequency sensor

Note: ** TR CU certificate is pending

DTM20 System Installation

DTM20-A4 Field-Wiring Diagram

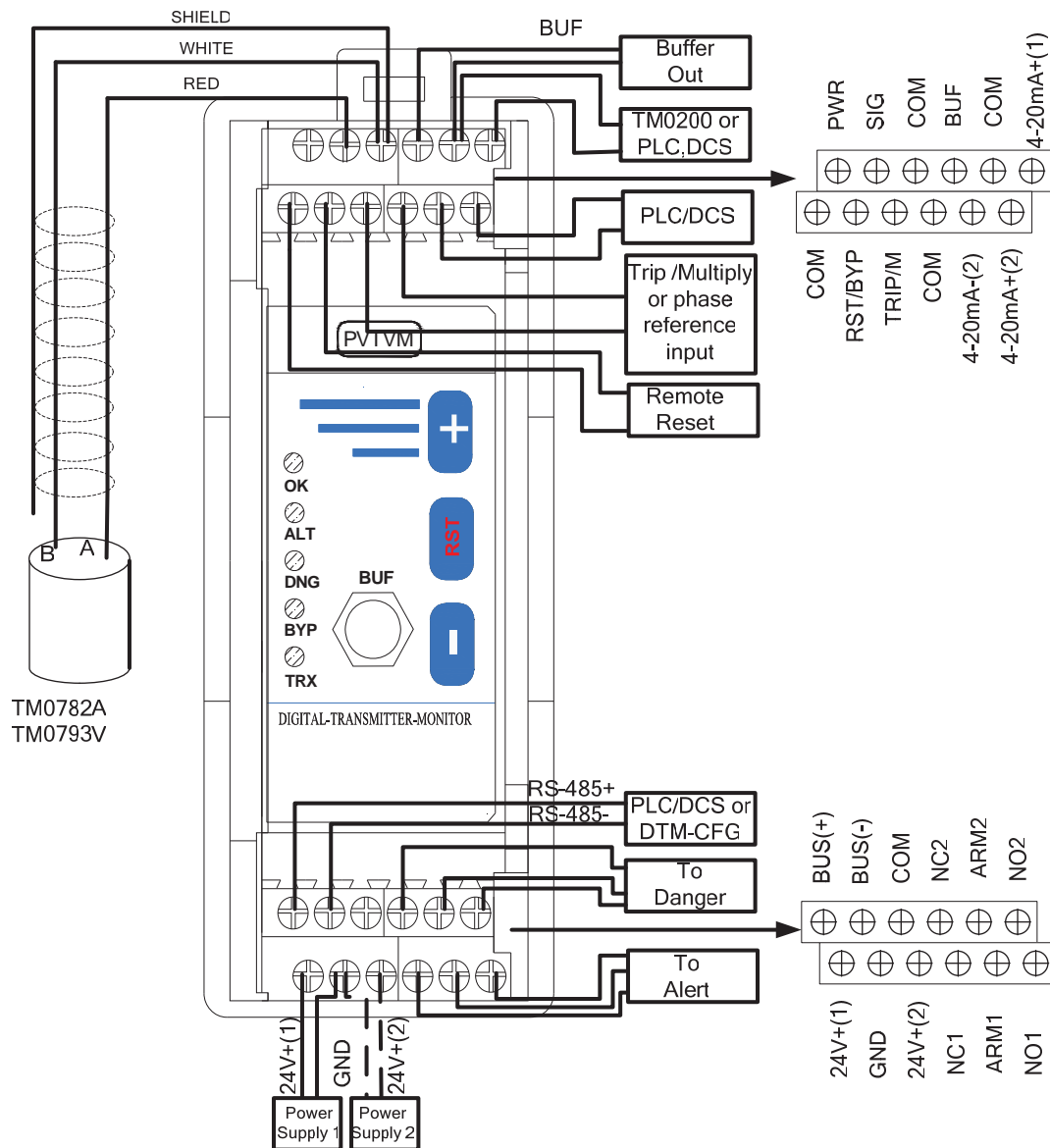

Note:

- ✓ Power supply 2 is optional connection used for redundancy.
- ✓ Alert and Danger relays are shown connected as normally open. Connect ARM and NC for normally closed.
- ✓ Connecting COM and RST/BYP with an external continuous or momentary closed switch will initiate a remote reset. Temporarily closing the switch will result in a system reset, continuous close will result in a system bypass.
- ✓ If DTM20 has the digital condition monitoring function, the Trip/Multi and COM pins are used for phase reference input. Thus, the DTM20 won't provide the Trip Multiply and the Trip Multiply property should be set to "None" in the DTM-CFG software.
- ✓ When using the signal condition monitoring function the DTM20 works with DTM10-501/502 to provide a phase reference output. In this case connect Trip/Multi of DTM20 with Trip/Multi of DTM10-501/502 and connect COM of DTM20 with COM of DTM10-501/502.

DTM20 Hazardous Area (Div. I, Zone I) Field-Wiring Diagram

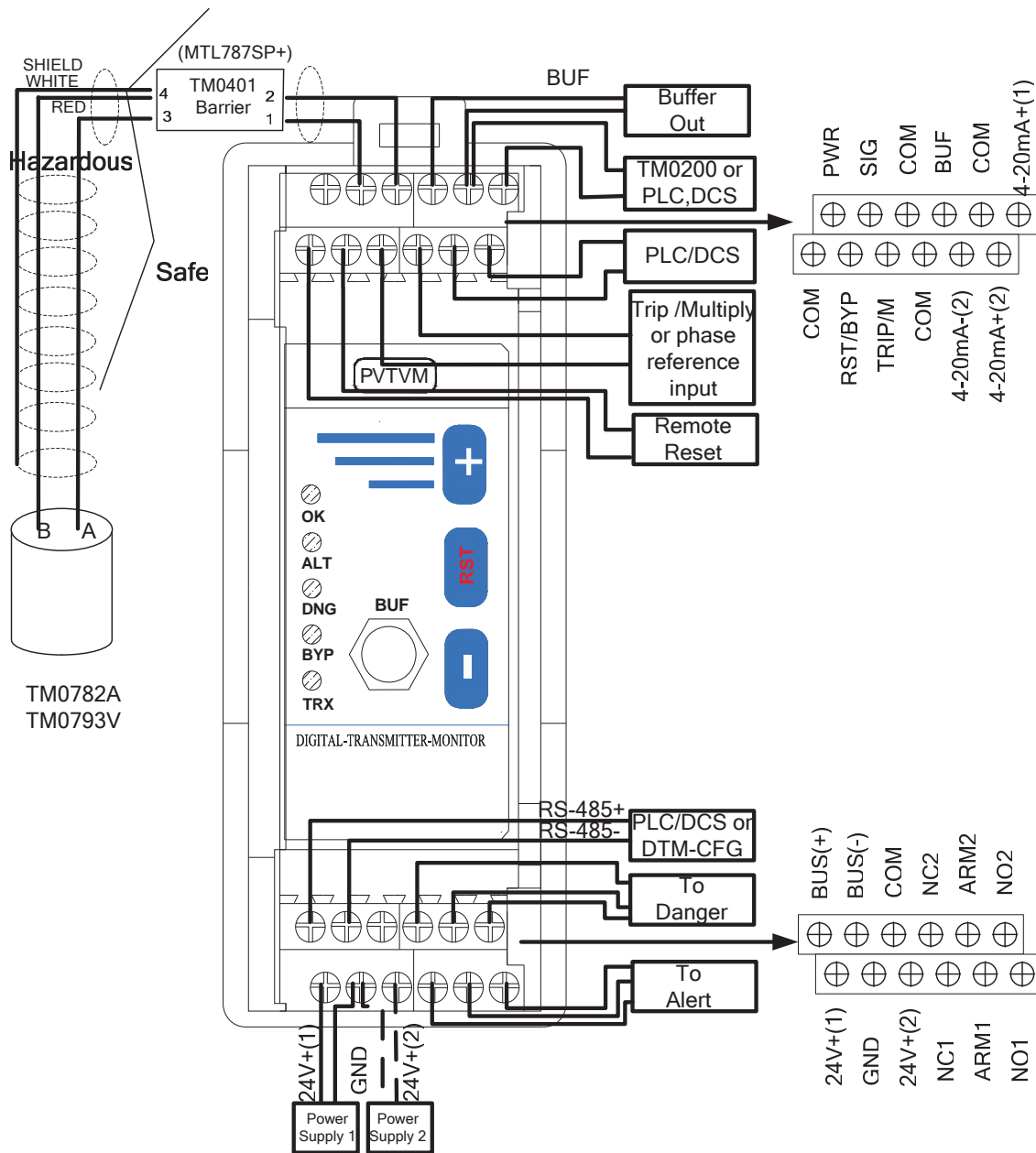

Note:

- ✓ Power supply 2 is optional connection used for redundancy.
- ✓ Alert and Danger relays are shown connected as normally open. Connect ARM and NC for normally closed.
- ✓ Connecting COM and RST/BYP with an external continuous or momentary closed switch will initiate a remote reset. Temporarily closing the switch will result in a system reset, continuous close will result in a system bypass.
- ✓ If DTM20 has the digital condition monitoring function, the Trip/Multi and COM pins are used for phase reference input. Thus, the DTM20 won't provide the Trip Multiply and the Trip Multiply property should be set to "None" in the DTM-CFG software.
- ✓ When using the signal condition monitoring function the DTM20 works with DTM10-501/502 to provide a phase reference output. In this case connect Trip/Multi of DTM20 with Trip/Multi of DTM10-501/502 and connect COM of DTM20 with COM of DTM10-501/502.

DTM-CFG Configuration and Calibration Software

DTM-CFG is the configuration and calibration software used to configure all DTM modules. DTM-CFG works with Windows XP or Windows 2000 operating system.

DTM-CFG can be connected to the DTM modules with the interface of a RS485-USB cable kit.

DTM-CFG combined with the DTM96 allows the user to remotely interface with 32 DTMs networked together in the field.

DTM-CFG Features

- ✓ DTM Configuration
- ✓ DTM Calibration

Specifications

Module Configuration:

- ✓ Module type selection
- ✓ Modbus ID address, Range
- ✓ Communication baud rate
- ✓ Auto manual search of communication port
- ✓ English or metric selection
- ✓ Password and security

Operation Configuration:

- ✓ Sensor and sensitivity selection
- ✓ Measurement unit selection
- ✓ Full-scale
- ✓ Dual-alarm set-points, time delay, latching
- ✓ Relay energized/de-energized. Relay programmed to Alert or OK
- ✓ OK set-points

Maintenance Calibration:

- ✓ ZERO calibration, SPAN calibration
- ✓ Probe linearization calibration
- ✓ Real-time overall and status display
- ✓ Record of overall and status
- ✓ Configuration parameter save as file

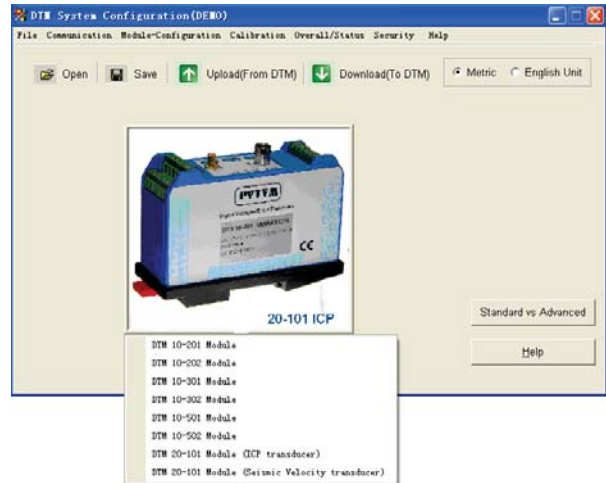

Order Information

DTM-CFG-K

DTM configuration and calibration software kit includes:

- ✓ DTM-CFG configuration and calibration software CD
- ✓ RS485-USB converter with cable
- ✓ User manual

DTM-CFG

DTM configuration and calibration software includes:

- ✓ DTM-CFG configuration and calibration software CD
- ✓ User manual

DTM-CAL

The DTM field calibration kit with probe calibration capability with any 5mm, 8mm and 11mm probe system.

The kit includes:

- ✓ DTM-CFG configuration and calibration software CD
- ✓ RS485-USB converter with cable
- ✓ TM0540 proximity probe field calibration kit
- ✓ User manual

Optional Accessories

RS485-USB: RS485 to USB converter with cable

RS232-USB: RS232 to USB converter with cable

DTM96: Isolated communication module

TM0540: Proximity probe field calibration kit

Accessories II

DTM-CFG

Configuration and calibration software

DTM RS485-USB

Converter from RS485 to USB for configuration with laptop computer

DTM RS485-RS232

Converter from RS485 to RS232 for configuration with desktop computer

PCM-TCP

Converter from Modbus RTU to TCP for configuration with desktop computer

PCM370

PCM370 condition monitoring software is ideal for plant wide condition monitoring, and trending of overall vibration levels

PT2060/98-PC

Touch panel PC with IP65 rating. Ideal to work with PCM370 and DTM-CFG

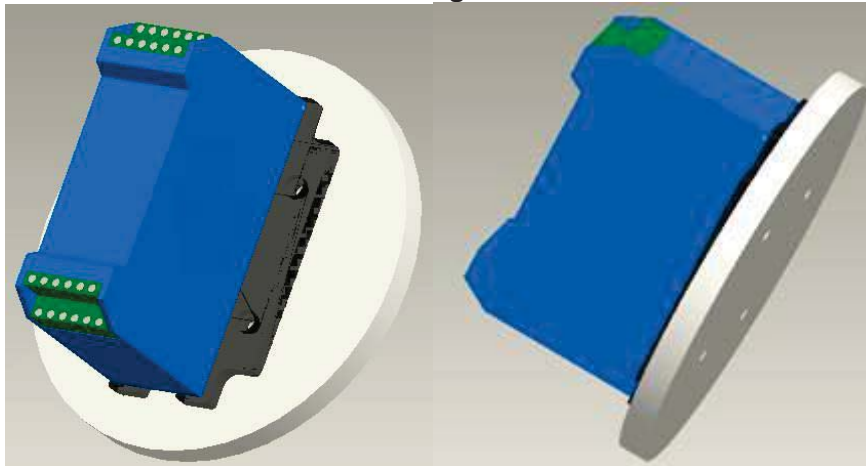
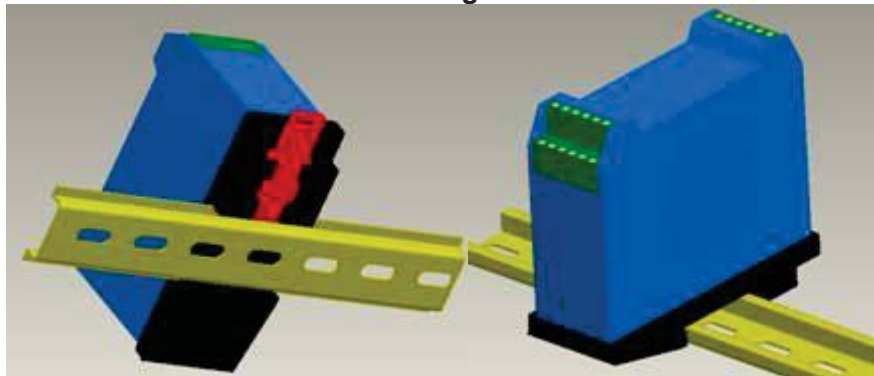
Mounting Plate and mounting Rail:**Mounting Plate****Mounting Rail**

DTM networking and on-line condition monitoring

