

VW5500 Vibration Welder Table Size 965 mm (38") by 455 mm (18")



FEATURES

- Electromechanical vibration head assembly (200-240 Hz)
- Patented Q Factor for comprehensive tool and machine diagnostics and preventive maintenance
- 15" color touchscreen HMI with remote I/O's
- Real time graphing of Amplitude, Force and Distance
- Intuitive and interactive comprehensive help menu
- Part parameter monitoring with programmable limits
- Weld by Time or Weld by Distance
- Programmable amplitude 0.5 mm to 1.8 mm (0.020" to 0.070") p-p
- Programmable Amplitude and Pressure profiling up to 5 steps
- Solid state 40 hp digital variable frequency drive
- Programming for up to 6 part in place sensors included (sensors not included)
- Programming for up to 6 pneumatic valves included (valves not included) with 6 extend & 6 retract sensors
- Programming for 2 vacuums (vacuum generator and valve not included)
- Programming for tool ID included. (adapter cable not included)
- Automatic tuning with auto ping mode with 0.01 Hz resolution
- Multilingual capabilities (English, Spanish, German, Japanese, Chinese, French, Czech)
- One-piece flame cut bridge (heaviest in class)
- Structural tubular steel table (heaviest in class)
- Hydraulic lift / clamp force maximum 20,000 N (4500 lb)
75.6 L (20 gallon) reservoir
- Light curtain for single switch activation

- Optical zero force for cycle start activation switches
- Interior work light

SPECIFICATIONS

- Table and maximum lower tool size 965 mm x 455 mm (38" x 18")*
- Door Opening 660 mm high x 1040 mm wide (26" x 41")
- Upper tool weight 15 kg - 40 kg (35 lb - 90 lb)
- Upper tool maximum size 450 mm x 760 mm (18" x 30")
- Lift table height 1040 mm (41")
- 500 mm (20") stroke, 630 mm (25") max. opening
- Small 1130 mm (44.5") x 2146 mm (84.5") foot print
- Maximum dB rating tooling and application dependent

Options

- Position adjustable cycle activation switches
- 12-Zone IR-Preheat machine and control upgrade. See IR-Preheat vibration welding datasheet for more information
- Servo lift table. See Servo vibrate welder datasheet for further information
- Exterior work light
- Custom paint specification
- Rear sliding door for pass through operation
- Programmable pneumatic valves for clamps and slides
- Programmable part-in-place sensing
- Custom lift table at lower heights available for taller vibration tools

* Tooling can in some instances overhang the back of table by modest amount. Consult Dukane for more information.

Vibration Welder Model VW5500 Floor Layout

VW5500

3084 kg (6800 lb)

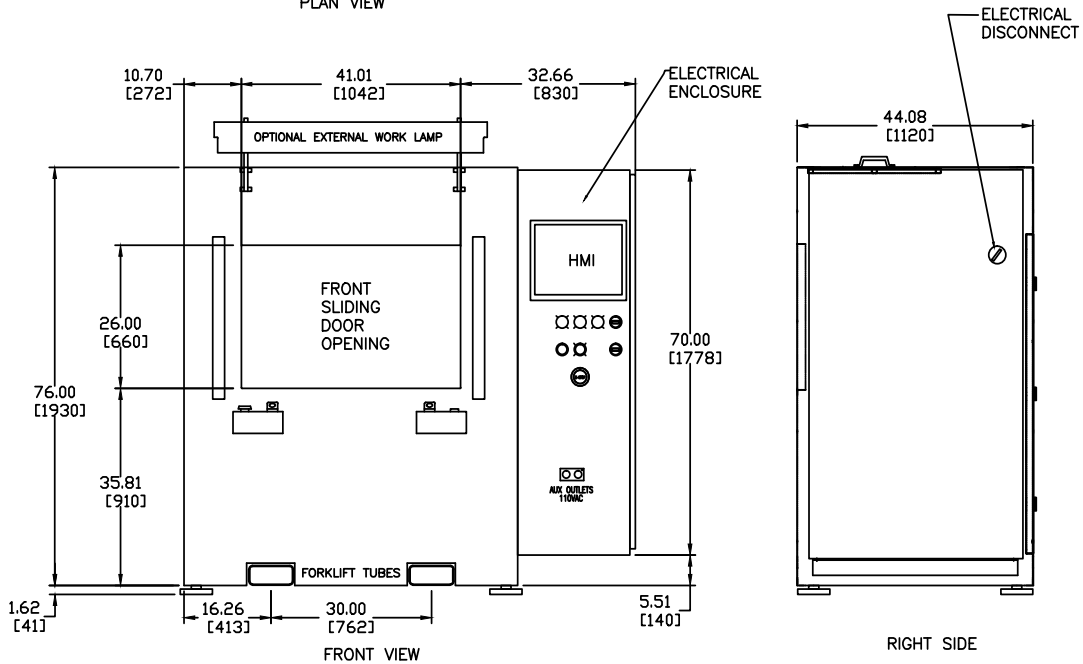
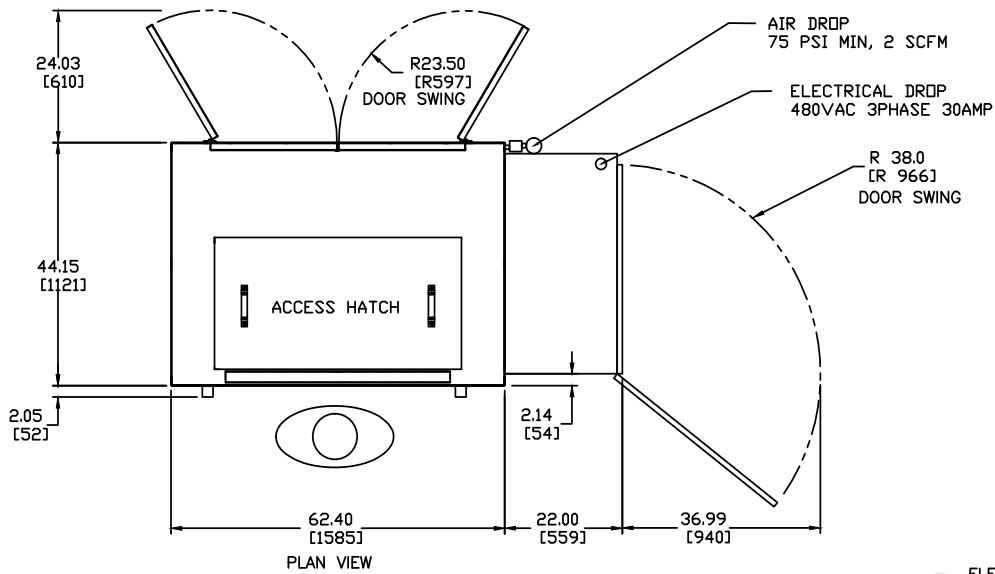

Fixture hole patterns and dimensions

