



The LPT machine design incorporates an upper tooling head with an industry standard 80 mm x 80 mm mounting bolt pattern. It also includes 6 mounting holes in the lower table to accept industry standard tooling. This machine platform is used for larger tooling including intake manifolds. While we have worked hard to match industry mounting standards, the industry will have to work hard to compete with our super rigid table, frame and slide assembly that has become the hallmark of Dukane vibration welding machines.

FEATURES

- Electromechanical vibration head assembly (200-240 Hz)
- Super rigid four rail table slide system
- One piece flame cut bridge (heaviest in class)
- Structural tubular steel table (heaviest in class)
- Solid state 65 hp digital variable frequency drive
- Hydraulic lift / clamp force maximum 5500 lbs. (25,000N) 20 gallon (75.6L) reservoir
- Real time graphing of amplitude, force & distance
- B&R 15" color, industrial computer HMI
- B&R input & outputs for all standard machine functions
- Intuitive and interactive comprehensive help menu
- Part parameter monitoring with programmable limits
- Programming for up to 6 part in place sensors included (sensors not included)
- Programming for up to 6 pneumatic valves included (valves not included) with 6 extended & 6 retract sensors
- Programming for 2 vacuum (vacuum generator and valve not included)
- Programming for tool ID included.
- Multilingual capabilities (English, Spanish, German, Japanese, Chinese, French, Czech)
- Automatic tuning with auto ping mode
- Programmable amplitude 0.020" to 0.070" (.05 to 1.8 mm)
- Weld by time or weld by distance
- Programmable Amplitude and Pressure profile up to 5 steps
- Interior work light

- Optical zero force cycle start activation switches
- Light curtain for single switch activation

SPECIFICATIONS

- Table and maximum lower tool size 52" x 24" (1320 x 610 mm)*
- Door Opening 26" high x 55" wide (660 x 1400 mm)
- Upper tool weight 60 – 180 lbs. (28 - 82 kg)
- Upper tool maximum size 20" x 44" (510 x 1120 mm)
- Low 41" (1040 mm) lift table height
- 20" (500mm) stroke, 25" (630mm) max. opening
- Small 52" x 102" (1.3 x 2.6 m) foot print
- Pneumatic manifold will support 6 optional tooling valves

OPTIONS

- Position adjustable cycle activation switches
- Exterior work light
- Optional PLC for Custom Functions (will not run standard machine operation).
- Custom paint specification
- Rear sliding door for pass through operation
- Programmable pneumatic valves for clamps and slides
- Programmable part-in-place sensing.
 - * Tooling can in some instances overhang the back of the table by a modest amount. Consult Dukane for more information.
 - ** Custom lift table or custom frame can be quoted to allow for an uninterrupted bucket of greater depth.

Vibration Welder Model VW5700LPT Floor Layout

VW5700LPT

7500 LBS

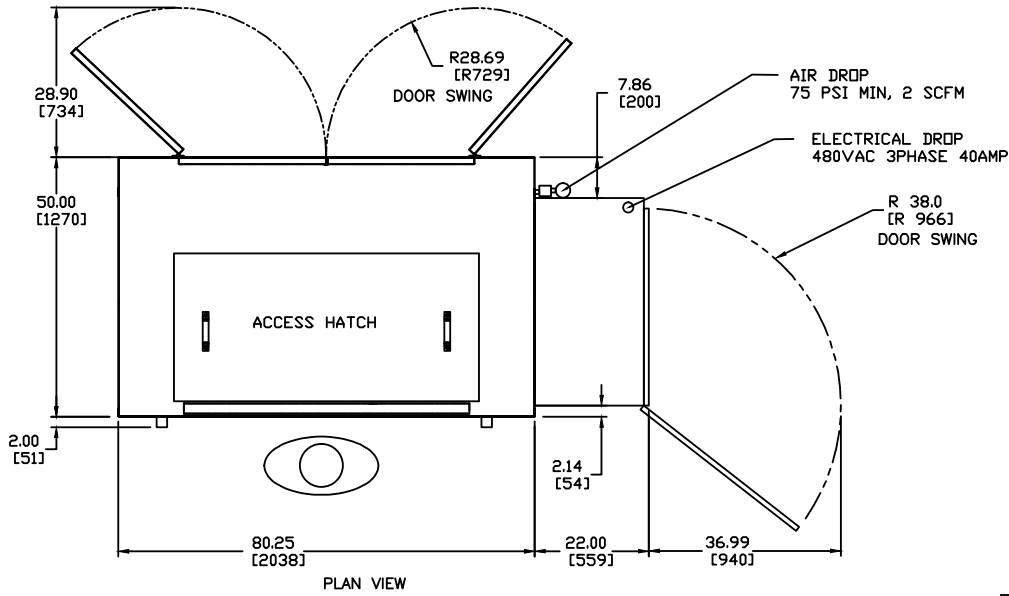

PLAN VIEW

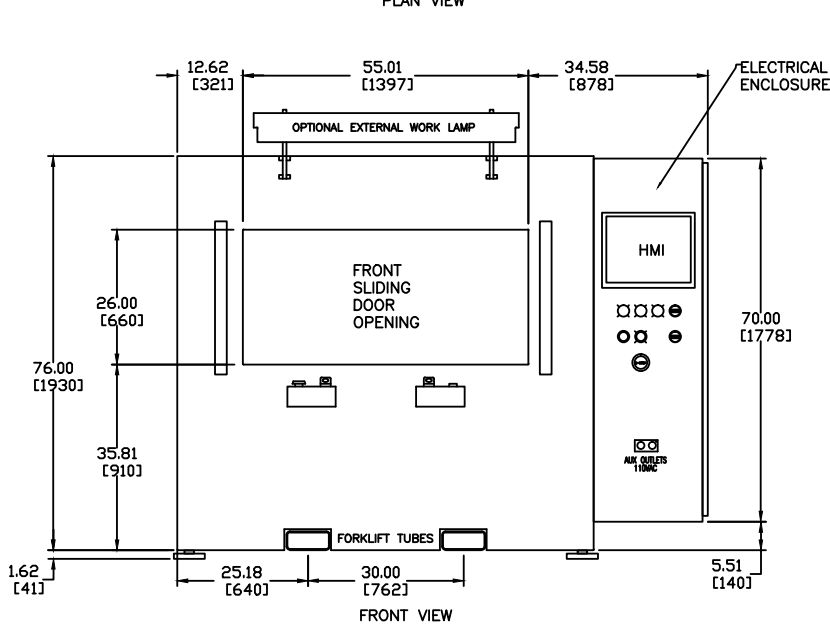

FRONT VIEW

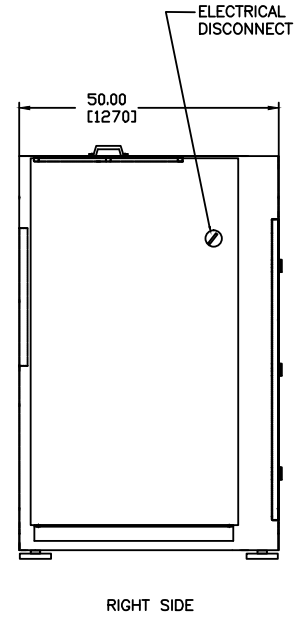

RIGHT SIDE

Fixture hole patterns and dimensions

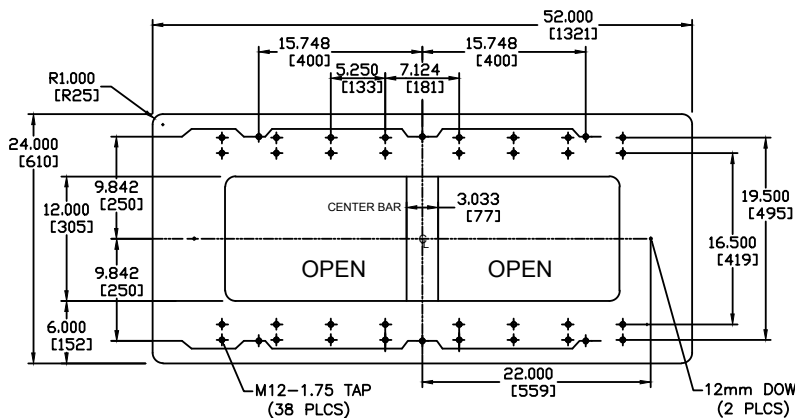

LIFT TABLE

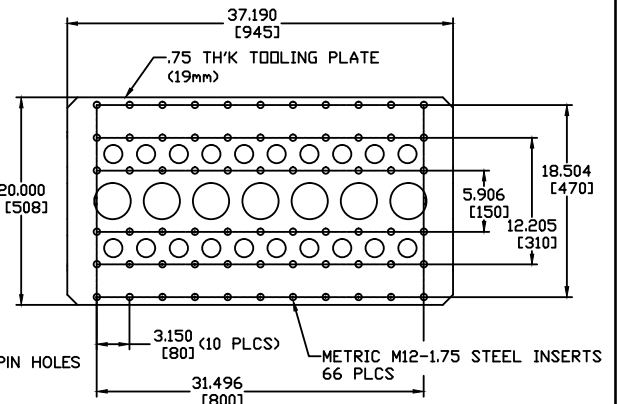

UPPER TOOL

Note: All specifications are subject to change without notice. Please consult Dukane Ultrasonics for any updated information.