

GMB40K

Boosting Innovation on a large scale

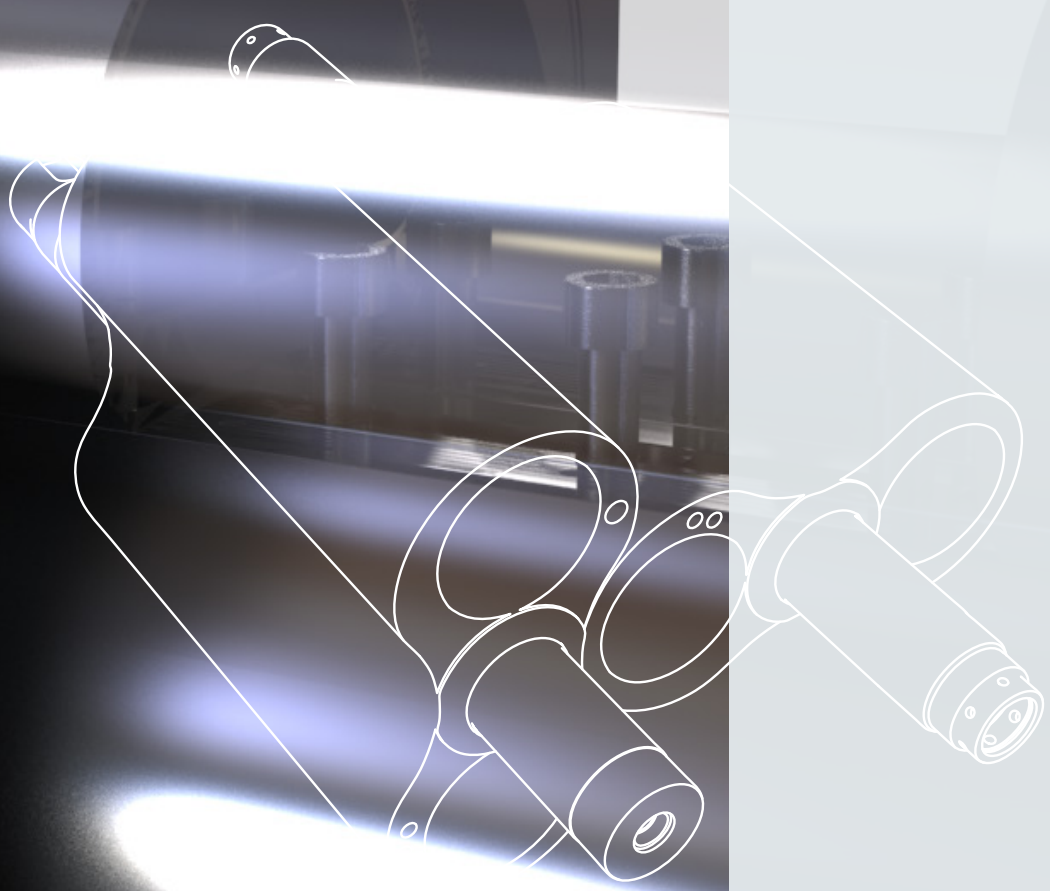
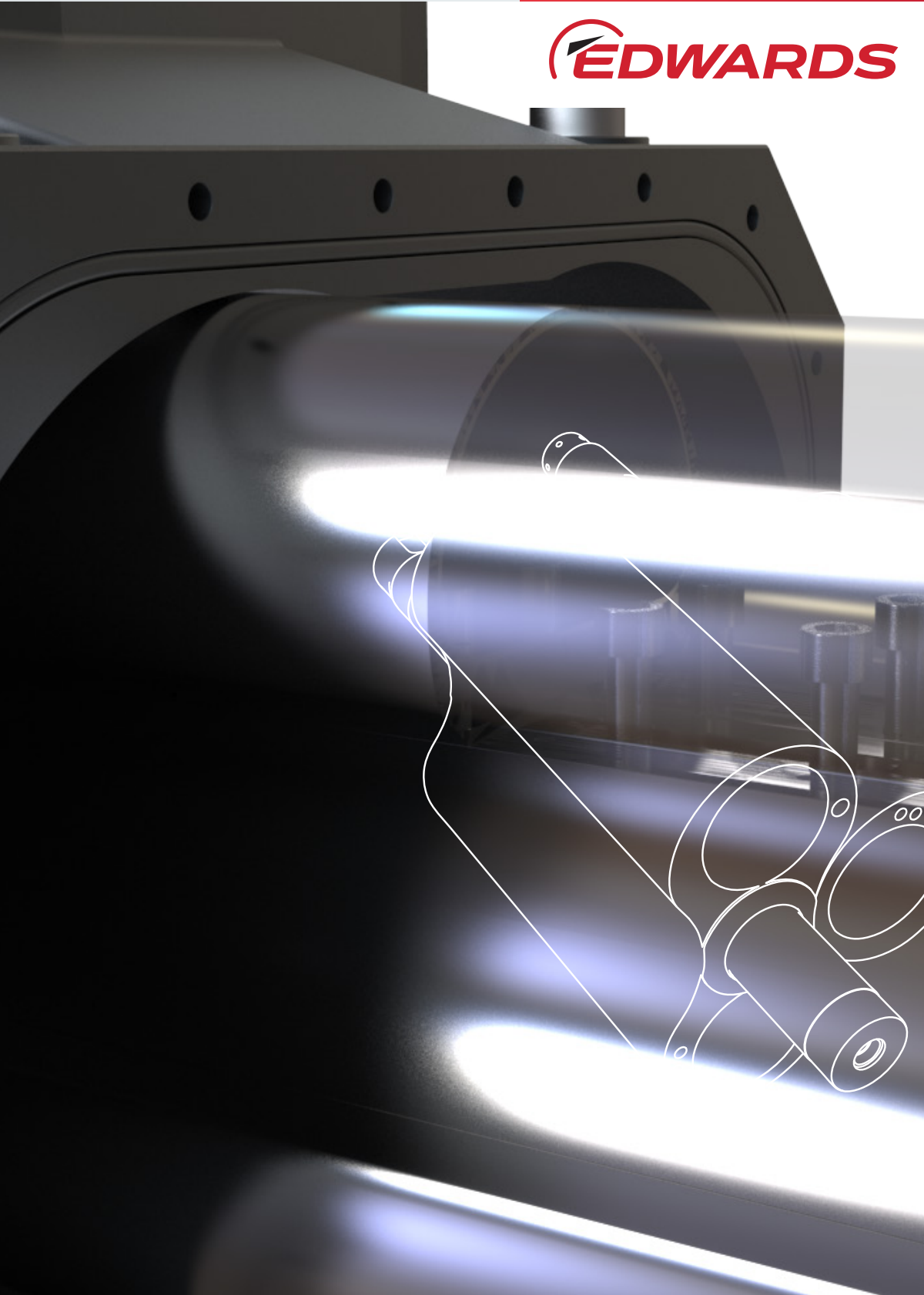

GMB40K HIGH CAPACITY ROOTS VACUUM BOOSTER

Composite rotor technology

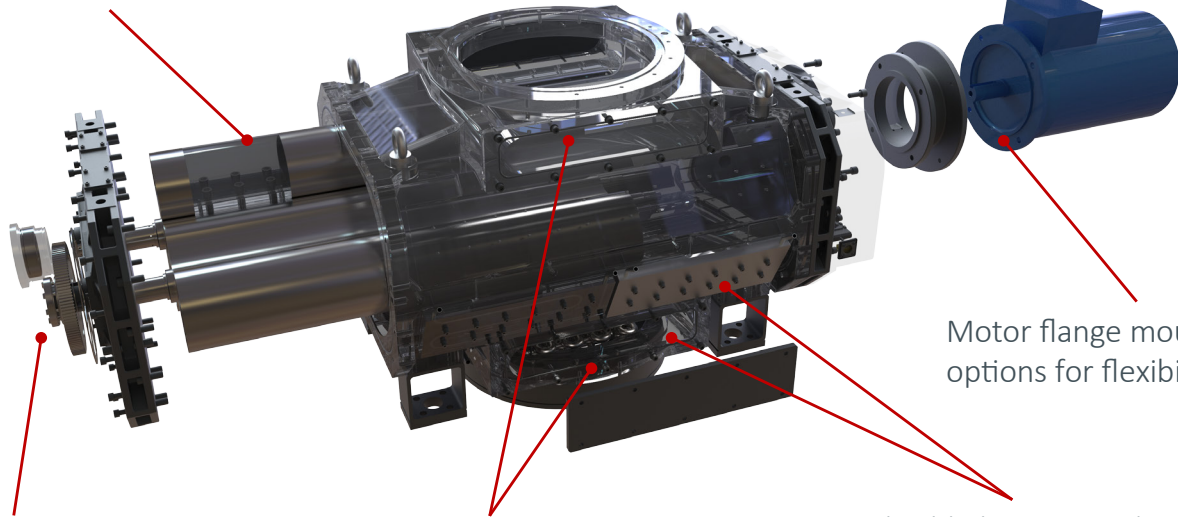

Bearing cartridge design enables ease of service

Maintenance access for harsh processes

Motor flange mounting options for flexibility

Flexible booster and gas cooling options

The new Edwards GMB40K with an innovative composite rotor design of high strength alloy-steel shafts with lightweight rotor lobes safely enable higher running speeds. This patented construction gives maximum displacement on an industry leading footprint.

ECONOMICAL – LOW COST OF OWNERSHIP

- Reduced Installation costs: Smallest footprint in class
- Increased efficiency: Lowest power consumption at vacuum
- Controllable vacuum: Ensures optimum process conditions

RELIABLE – PEACE OF MIND FOR YOUR PROCESS

- Robust: Designed for harsh applications
- Service: Minimal in situ service to maximise process uptime
- Increased safety: Ensures mechanical integrity during process malfunctions

FLEXIBLE – MULTIPLE SYSTEMISATION OPTIONS

- Global standards: IEC and NEMA Motor options
- Hazardous area options: ATEX / Class 1 Div 1 ready.
- Systems Engineering: Scalable technology with multiple backing configurations

SMALL FOOTPRINT – HIGH CAPACITY

Edwards innovative composite rotor technology ensures high performance on the smallest footprint and weight. This ensures the highest degree of flexibility when designing large vacuum systems.

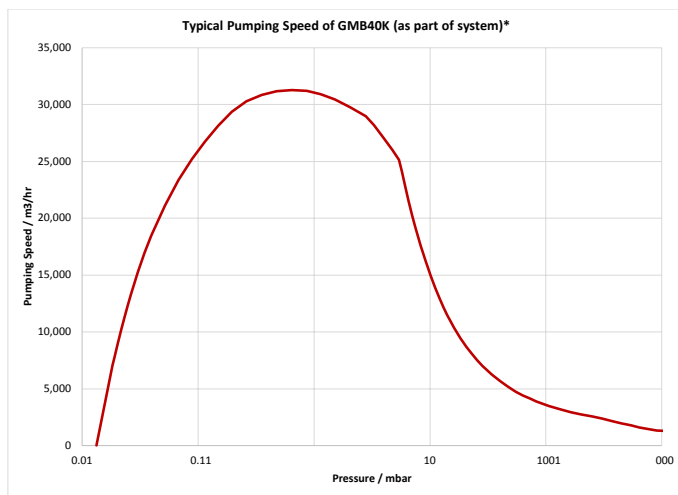
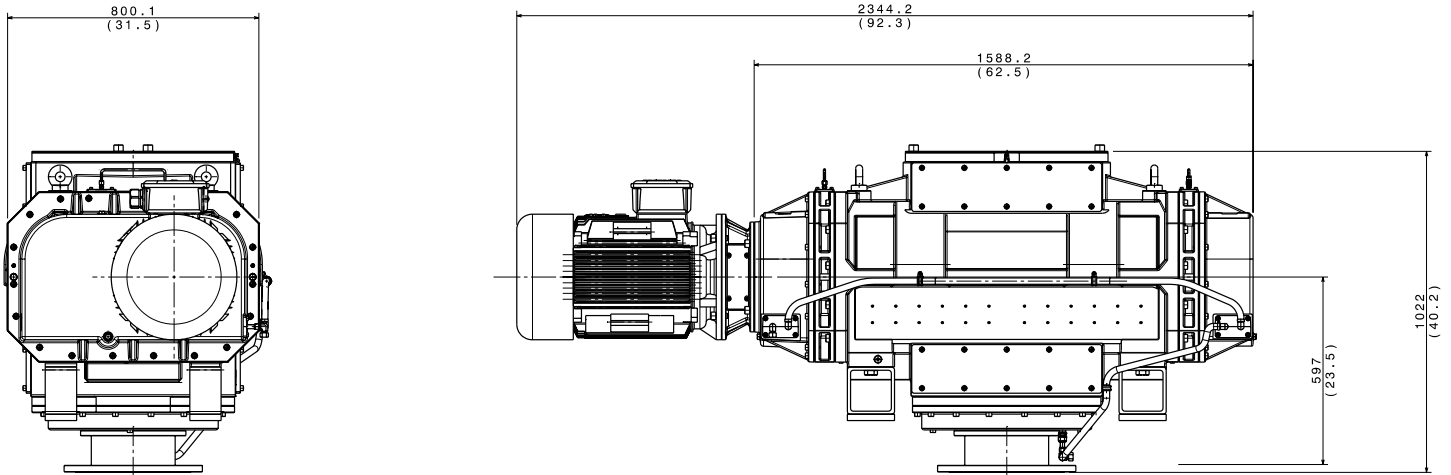

With a 6,700 m³/hr backing pump system. This can be achieved by 3 Standard Edwards GXS vacuum pumps.

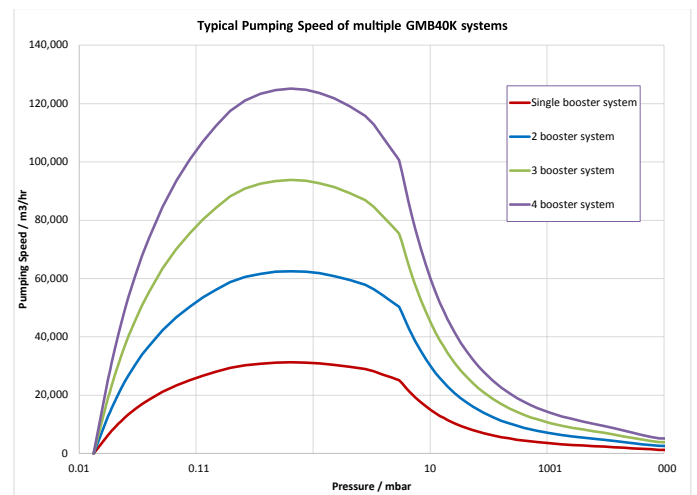

Scalable technology for simple design of large pumping systems or adding redundancy to valuable processes

EDWARDS THE PARTNER OF CHOICE

Edwards believes in delivering results that bring value to our customers by using our breadth of industry experience to identify and apply solutions to your problems. Using the most innovative and up-to-date modelling techniques, we can optimise the pumping configuration for customers to provide a system design giving the maximum performance in the most reliable and cost-effective way

GMB40K Technical data		Units
Pumping speed	31,000	m ³ /hr*
Max ΔPressure across booster	25	mbar
Ultimate Pressure	<0.01*	mbar
Total input power at ultimate	2.5 3.4	KW hp
Rotational speed	540 min 3960 max	rpm
Motor power	IEC - 30 NEMA - 40	KW hP
Noise	80dB(A)	
Vibration	<4 <0.16	mm s ⁻¹ inch s ⁻¹
Cooling water connections	X/Y" BSP	
Cooling water temperature	5-40 41 - 104	°C °F
Minimum cooling water flow (@max temp)	10 2.6 US gal min ⁻¹	Litres min ⁻¹ US gal min ⁻¹
Cooling water ΔPressure	1.0 14.7	bar psi
Recommended Lubrication type	Mobil Oil SHC629	
Lubricant quantity	7 1.85	Litres US gal
Connection flanges	Inlet DN500 Outlet ISO250	
Weight	2260 4980	Kg lbs
Dimensions	See drawing	
Ambient Temperature	-20 – 40 -4 - 104	°C °F

Publication Number:3602 202 7 01

© Edwards Limited 2017 All rights reserved.

Edwards and the Edwards logo are trade marks of Edwards Limited.

Whilst we make every effort to ensure that we accurately describe our products and services, we give no warranty as to the accuracy or completeness of any information provided in this brochure.

Edwards Ltd, registered in England and Wales No. 6124750, registered office: Manor Royal, Crawley, West Sussex RH10 9LW, UK
Part of the Atlas Copco Group

Global contacts

UK
+44 1293 528844
08459 212223

Belgium
+32 2 300 0730

France
+33 1 4121 1256

Germany
0800 000 1456

Italy
+ 39 02 48 4471

Israel
+ 972 8 681 0633

China
+86 400 111 9618

India
+91 20 4075 2222

Japan
+81 47 458 8831

Korea
+82 31 716 7070

Singapore
+65 6546 8408

Taiwan
+886 3758 1000

USA
+1 800 848 9800

Brazil
+55 11 3952 5000

