

## INCREMENTAL ROTARY ENCODER SHARED TECHNOLOGY FOR “HOLLOW AND SOLID SHAFT”



Type HTP 96/000 ... S4



Plug-in junctions



Type OPTI 96/121

The incremental rotary encoder scans the fine grid of a metal disc using the principle of photoelectric scanning. The rotary encoders are available as single and double encoders. The dimensions of both cases are identical.

The new programming chip enables the customers to define the required pulse number using solder bridging. The ratio of the divider remains.

Pulse numbers in the range of 10 to 4096 are possible.

The encoders are particularly suitable for harsh environments such as paper- or steel industry.

- Robust industrial construction for the heavy engineering industry (e.g. paper, calender, steel and crane industry)
- Double supported with sealing ring against dirt and splash water IP 66
- Ambient temperature max. + 100° C
- Quick replacement of encoder by means of pluggable connection top cover
- Programming of the pulse number by the customer
- EMV-compatibility according IEC 801-4
- Central mounting and pulling unit on hollow shaft rotary encoders
- ~~Insulated hollow shaft, proof voltage 2 kV~~

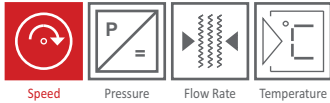

## General technical data

- EMV - threaded cable connection
- Flange mounting on Ds-motors or Gs-motors as well as floor installation
- Optical incremental pulse scanning with 90° phase shift
- Symmetrical line driver permits cable lengths up to 1200 m
- Standard pulse numbers are 1000 up to 2048 pulses / revolution
- Option P / P4: programmable pulse number for the systems A / B by means of divider
- Option N: Zero pulse

STANDARD PULSE NUMBER	PROGRAMMABLE PULSE NUMBERS (OPTIONS P, P4)
1000	(2000) <sup>(1)</sup> , 1000, 500, 250, 200, 125, 100, 50, 25
1024	(2048) <sup>(1)</sup> , 1024, 512, 256, 128, 64, 32, 16
1080	(2160) <sup>(1)</sup> , 1080, 540, 360, 270, 216, 180, 135, 108, 90, 54, 45, 27
1200	(2400) <sup>(1)</sup> , 1200, 600, 400, 300, 240, 200, 150, 120, 100, 75, 60, 50, 25
2000	(4000) <sup>(1)</sup> , 2000, 1000, 500, 250, 200, 125, 100, 50, 25
2048	(4096) <sup>(1)</sup> , 2048, 1024, 512, 256, 128, 64, 32

(1) no incremental signal

## Mechanical data

INERTIA MOMENT	ca. 18 g cm <sup>2</sup>
ANGULAR ACCELERATION, MAX.	104 rad/s <sup>2</sup>
INPUT TORQUE	ca. 1 Ncm
STRESSABILITY OF THE SHAFT	axial 40 N/ radial 30N
DYNAMIC STRENGTH	≤ 10*g ≈ 100m/s <sup>2</sup> , 20 Hz ... 2 kHz, DIN IEC 68-2-6
SHOCK RESISTANCE	≤ 100*g ≈ 100m/s <sup>2</sup> , DIN IEC 68-2-27
MAXIMUM SPEED	10000 Upm
MAXIMUM SPEED (LIMIT)	13000 Upm
SHAFT	Stainless steel 1.4305
CASE	Anodically oxidized
PROTECTION CLASS	IP66 according to IEC 529
WEIGHT	approx. 850g or 1200g

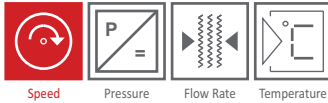

## Electrical data

		HTL	TTL OPTION S1	TTL OPTION S2
FREQUENCY RANGE		0 ... 200 kHz	0 ... 300 kHz	0 ... 300 kHz
OPERATING VOLTAGE	Ub	8 ... 30 V, DC	4,75 ... 5,5 V, DC	8 ... 30 V, DC
CURRENT CONSUMPTION WITHOUT LOAD	Ia	max. 45 mA	max. 45 mA	max. 45 mA
MAX. OUTPUT CURRENT, SHORT-CIRCUIT PROOF	Ia	± 50 mA	± 50 mA	± 50 mA
INTERNAL RESISTANCE OF OUTPUTS	Ri	55 Ω ± 25%	55 Ω ± 25%	55 Ω ± 25%
OUTPUT VOLTAGE Lo	UaL			
WITHOUT LOAD		0,3 V	0,3 V	0,3 V
WITH LOAD		3,1 V ( 50 mA )	1,4 V ( 20 mA ) <sup>(1)(2)</sup>	1,4 V ( 20 mA ) <sup>(1)(2)</sup>
OUTPUT VOLTAGE Hi	UaH			
WITHOUT LOAD		Ub - 1 V	Ub - 0,3 V	4,6 V
WITH LOAD		Ub - 4,1 V	Ub - 1,4 V (20 mA) <sup>(1)</sup>	3,5 V (20 mA) <sup>(1)</sup>
RISE TIME				
10%UA <-> 90%UA, CL=100pF	tr, tf	< 0,5 us	< 0,5 us	< 0,5 us
AMBIENT TEMPERATURE	Tu	-10°C ... 100°C	-10°C ... 100°C	-10°C ... 100°C

(1) These levels will be reached on differential operation of the line driver at a closed line having a surge impedance of 110 Ω. The levels lie within the RS 422 specification.

(2) A maximum current I<sub>IO</sub> of 8 mA according to the 5 TTL-inputs is valid for the selection of real TTL -loads.

If bigger TTL-loads are operated, the line must be closed by a pull-down-resistance, most suitable according to the value of the surge impedance of the line.

## Max. phase error of the incremental signal

	< 20 kHz	BEI 120 kHz
PULSE WIDTH	180°el ± 15°el	180°el ± 30°el
PHASE SHIFT	90°el ± 7°el	90°el ± 15°el
MAX. QUADRANT ERROR	± 15°el	± 30°el

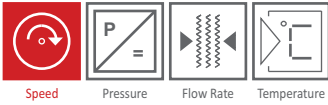

### Order information

HTP 96/000	Hollow shaft rotary encoder	shaft Ø 16 mm	flange Ø 97 mm
HTP 96/015	Hollow shaft rotary encoder	shaft Ø 15 mm	flange Ø 97 mm
HTP 96/014	Hollow shaft rotary encoder	shaft Ø 14 mm	flange Ø 97 mm
HTP 96/012	Hollow shaft rotary encoder	shaft Ø 12 mm	flange Ø 97 mm
HTP 96/010	Hollow shaft rotary encoder	shaft Ø 10 mm	flange Ø 97 mm
<del>HTPI 96/000</del>	<del>Insulated hollow shaft rotary encoder</del>	<del>shaft Ø 16 mm</del>	<del>flange Ø 97 mm</del>
OPTI 96/000	Solid shaft rotary encoder	shaft Ø 10 mm	flange Ø 97 mm
OPTI 96/121 (120)	Solid shaft rotary encoder	shaft Ø 10 mm	flange Ø 120 mm
OPTI 96/115	Solid shaft rotary encoder	shaft Ø 11 mm	flange Ø 115 mm

BASE PULSE NUMBER	-1											1000 pulses / rotation
SYSTEM A	-2											1024 pulses / rotation
	-3											1200 pulses / rotation
	-4											2000 pulses / rotation
	-5											2048 pulses / rotation
	-6											1080 pulses / rotation
	0											Not programmable
SYSTEM A	P											System A programmable
ZERO PULSE			N									Zero pulse, current consumption under load 90 mA total
PULSE NUMBER PROGRAMMING A				-nnnn								Pulse to be programmed for system A on delivery or base pulse number without option P
SUPPLY												HTL-output, supply 8 - 30 V, DC
										-S1		TTL-output, supply 5 V, DC
										-S2		TTL-output, supply 8 - 30 V, DC
TYPE										-S4		Double-rotary encoder (System A and B)
										-P4		Programmable system B
SUPPLY												HTL-output, supply 8 - 30 V, DC
										-S1		TTL-output, supply 5 V, DC
										-S2		TTL-output, supply 8 - 30 V, DC
PULSE NUMBER PROGRAMMING B											-xxxx	Pulse number to be programmed for system B on delivery or base pulse number without option P4

Rev-Nr.: DS 101 E V.0.5 2020-02-14

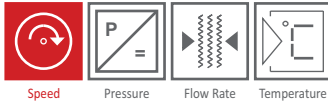

## Connection diagrams

### Terminal strip single transmitter

Incremental rotary encoder without zero pulse | with zero pulse

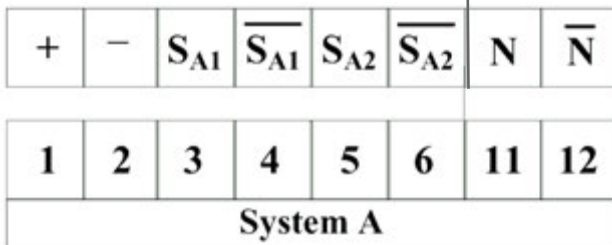

#### Legend

Standard design

+/- Operating voltage UB ( - is electronic-GND)

$\overline{S_{A1}}$  Signal A1

$S_{A1}$  Signal A1 complementary

$\overline{S_{A2}}$  Signal A2

$S_{A2}$  Signal A2 complementary

with Option zero pulse "N"

N Zero pulse

$\overline{N}$  Zero pulse complementary

with Option "P"

+/- Operating voltage UB ( - is electronic-GND)

$\overline{S_{A1}}$  Signal A1 \* factor K/ alternative S1 \* 2 (jumper 9)

$S_{A1}$  Signal A1 complementary

$S_{A2}$  Signal A2 \* factor K/ alternative V/R-signal (jumper 7)

$S_{A2}$  Signal A2 complementary

### Terminal strip double transmitter

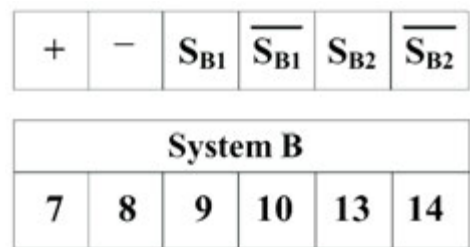

+/- Operating voltage UB ( - is electronic-GND)

$\overline{S_{B1}}$  Signal B1

$S_{B1}$  Signal B1 complementary

$\overline{S_{B2}}$  Signal B2

$S_{B2}$  Signal B2 complementary

with option "P4": programmable outputs B1, B2

## Output signals

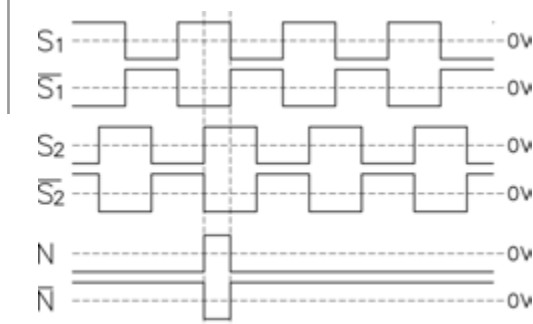



Speed



Pressure



Flow Rate



Temperature

## Dimensional drawing HTP-, HTP1-96/000

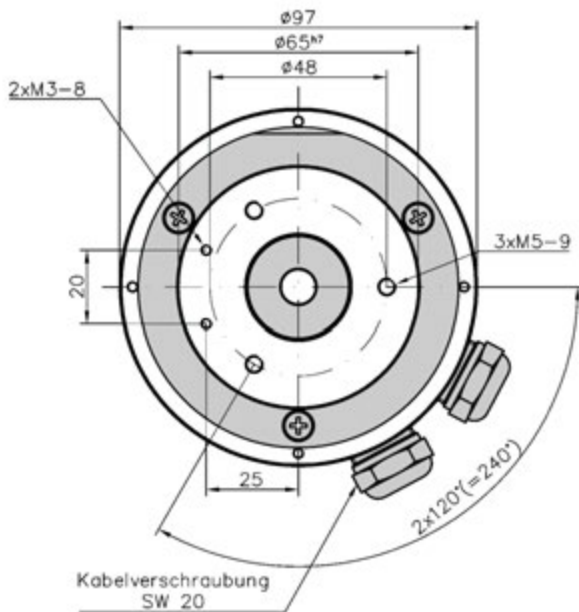
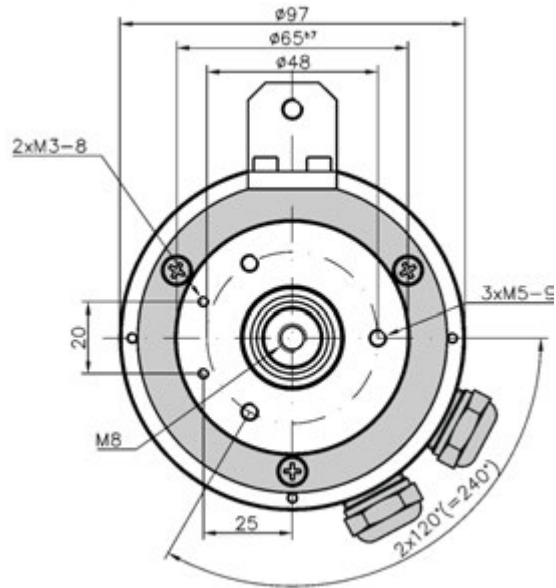
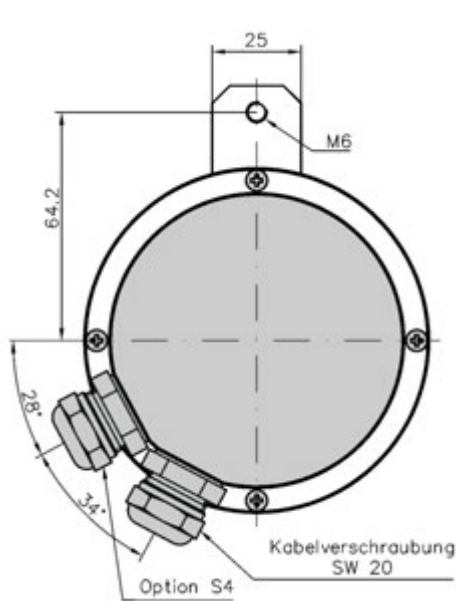

Legend:  
Kabelverschraubung threaded cable connection

Rev.-Nr.: DS 101 E V.0.5 2020-02-14

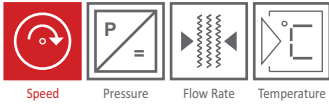

## Dimensional drawing OPTI 96/000

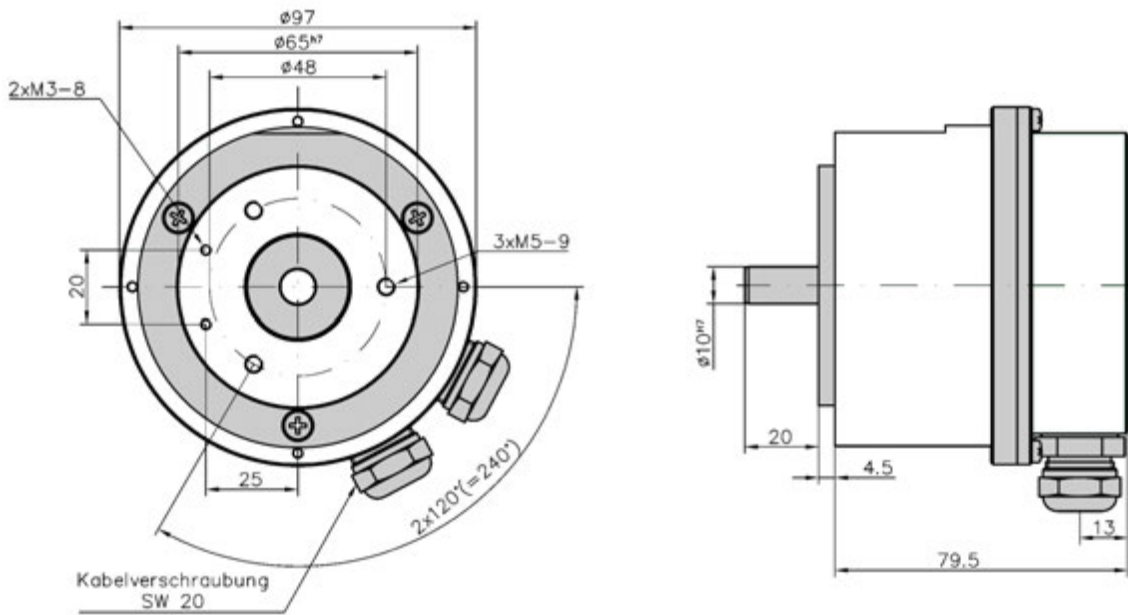

## Dimensional drawing OPTI 96/121 (120)

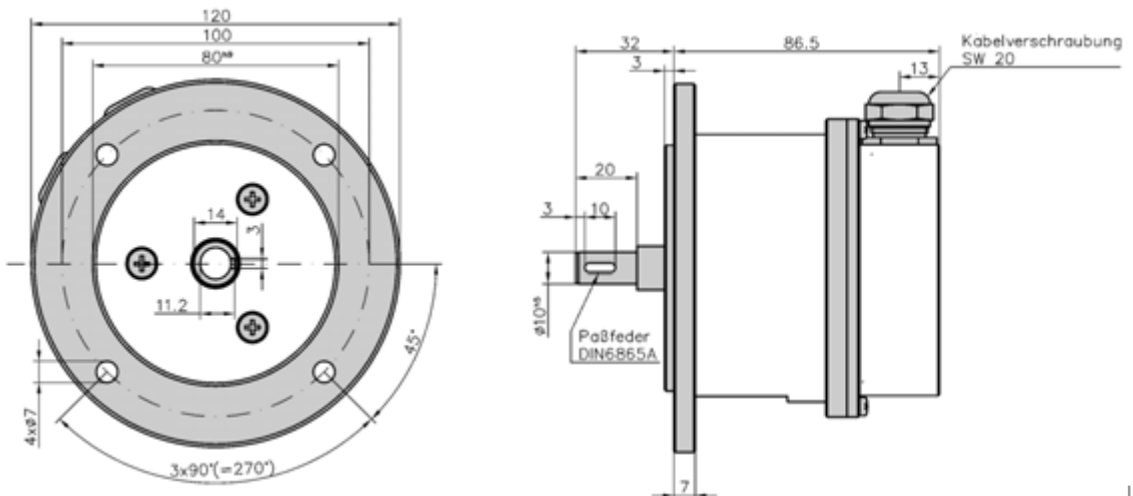

Legend:  
Kabelverschraubung threaded cable connection  
Paßfeder parallel key

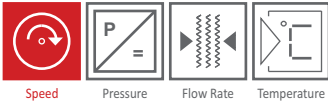

## Dimensional drawing OPTI 96/115 (Euro-

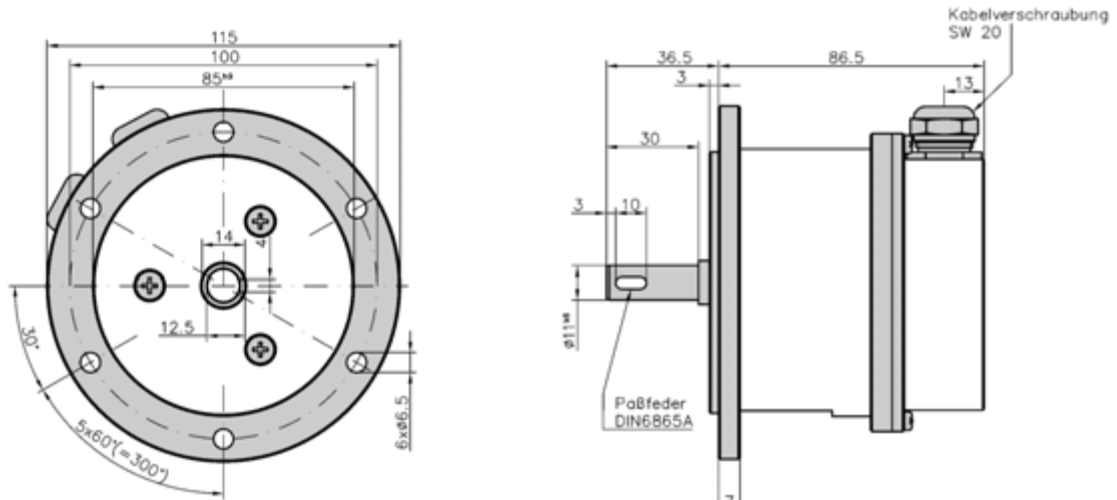

Legend:  
 Kabelverschraubung threaded cable connection  
 Paßfeder parallel key

Rev.-Nr.: DS 101 E V.0.5 2020-02-14

Your local contact: