

# MRS Extruder

## Technical Data

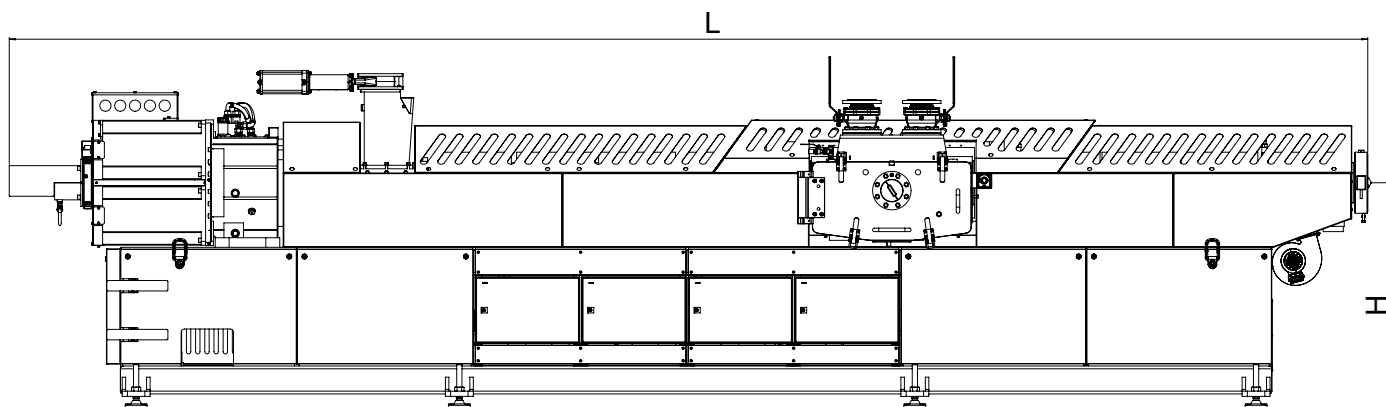

Subject to modifications.

	MRS 35	MRS 50	MRS 70	MRS 90	MRS 110	MRS 130	MRS 160	MRS 200
Screw diameter Ø mm	35	50	70	90	110	130	160	2x130
Drive rating kW	25	55	107	170	235	355	540	2x355
Max. screw speed (rpm)	220	210	165	135	120	110	90	110
Extrusion height H mm	700	1000	1150	1150	1300	1300	1450	1600
Length L mm	2250	2800	4830	5700	6650	7785	10510	8275
Width B mm	480	850	1200	1490	1520	1560	1650	2935
Weight approx. kg	700	1550	3250	5450	7130	7700	15350	16750
<b>Throughput rate in kg/h</b>								
PET	35	80	200	450	700	1.000	1.400	2.000
PP + PE	25	60	130	300	450	750	1.000	1.600
PA	28	70	160	360	560	880	1.200	1.900
PS	30	60	150	350	450	750	1.100	1.500

\* As each extruder is engineered to a specific project, the technical data may deviate from the values listed in this table. Detailed information on the relevant technical data is provided to you with your quotation.