



HANSA-TMP
MANUFACTURING YOUR SUCCESS

HT 16 / M / 130 / 0122 / E

THE PRODUCTION LINE OF HANSA-TMP

Variable Displacement Closed Loop System Axial Piston Pump

TPV 1100



INDEX

General Information.....	4
Technical Specifications.....	5
System Design Parameters.....	5
Performance Diagram.....	6
Torque Calculation.....	7
General Instructions.....	8 - 9
Hydraulic fluid.....	10
Hydraulic fluid Filtration.....	11
TPV 1100	
Order Code.....	12 - 14
Single Pump - Direct Mechanical Control (overall dimensions).....	15
Single Pump - Hydraulic Servo Control (overall dimensions).....	16
Tandem Pump - Installation Drawing (overall dimensions).....	17
Triple Pump - Installation Drawing (overall dimensions).....	18
Shafts.....	19 - 21
Mounting Flanges.....	22
DM Direct Mechanical Control without Lever.....	23
BC Tapered Bush.....	24
LC Direct Mechanical Control with Lever.....	25
DMS Control Lever with Return to Zero Position (torsion spring).....	26 - 27
DMZ Control Lever with Return to Zero Position (compression spring).....	28 - 29
SHI Hydraulic Servo Control.....	30 - 31
SHIC Compact Hydraulic Servo Control.....	32 - 33
SEI 1 - 2 Electro-proportional servo control (AMP Junior).....	34 - 36
SEI 1 - 2 Electro Servo Control (DEUTSCH).....	37 - 39
Control Device Position - Primary and Secondary Pump.....	40 - 41
Gear pump connections.....	42
Rear Pump Mounting Flanges C Standard Version - B1 Compact Version.....	43
Rear Pump Mounting Flanges B1 - B2.....	44
Rear Pump Mounting Flanges B2 Compact Version - SA.....	45 - 46
OPTIONAL LB Lever By-pass.....	47
OPTIONAL VS Flushing Valve.....	48
OPTIONAL VSLB Flushing Valve + Lever By-pass.....	49
OPTIONAL SB Screw By-pass.....	50
OPTIONAL FB SAE-A - SAE-B Mounting Flange.....	51
OPTIONAL ST Coupling Z = 9 / Z = 13.....	51
OPTIONAL FBST Mounting Flange + Coupling.....	52
Troubleshooting.....	53
Accessories.....	54

GENERAL INFORMATION

- TPV 1100 is a variable displacement, compact tandem axial piston pump, with swashplate system, for closed loop hydrostatic transmissions.
- Flow rate is proportional to the rotation speed and displacement, and is continuously variable.
It increases as the swashplate angle moves from "0" to maximum position.
If the swashplate is positioned beyond the neutral point, the flow rate respectively follows one of the two directions.
- The TPV 1100 is equipped with a boost pump, "gerotor" type of new design and high efficiency to keep the circuit pressurised, to compensate the oil leakages of the hydrostatic transmission, to avoid cavitation of the piston pump and to supply low pressure oil flow to the remote controls of the pumps and of the hydraulic transmission (max 3 MPa).
- The standard version is of mechanical type on which, by means of a lever, the change of flow in the two directions is obtained.
- This series of pumps can be with a hydraulic servo control or electro-proportional control which allows the control of the pump by means of hydraulic or electric joysticks.
- Moreover the pump is fitted with relief valves and it is adapted for assembly of auxiliary gear pumps.
- The compact tandem TPV 1100, are available with splined or parallel shaft and can be supplied with options such as purge valve, screw by-pass valve and, for security, "man on board" valve.
- The piston pumps are to be considered as individual components for the purposes of Directive 98/37/EC, therefore have been built to be integrated into a circuit or to be assembled with other components to form a machine or system. They can be operated only after they have been installed in the machine/system which they are intended for.
- The TPV 1100 pumps must be used to create, manage and regulate oil flow in a closed loop system. Any other use should be considered improper.
- The pumps are built according to the technology normally used for this type of product. There is the risk of injury or damage to personnel during their installation and use if you do not respect the normal safety instructions or if used by untrained personnel.

TECHNICAL SPECIFICATIONS

PUMP MODEL		TPV 6-7	TPV 8-7	TPV 9-7	TPV 11-7	TPV 12-7	TPV 13-7	TPV 15-9	TPV 17-9	TPV 18-9	TPV 19-9	TPV 21-9
Max. Displacement	cm ³	7,4	8,9	9,6	11,2	12,8	13,6	15,00	17,1	18,2	19,4	21,15
Flow rating ⁽¹⁾	l/min	25,01	31,96	34,74	40,32	46,08	48,88	54,00	61,77	66,37	69,84	76,4
Power rating ⁽¹⁾	kW	8,75	11,18	12,15	14,11	16,12	17,11	18,9	21,61	23,23	24,44	31,73
Boost pump displacement	cm ³ /n	3,9 (rear cover closed B1, B2) 4,7 (rear cover SAE-A)										
Rated pressure	MPa	30						25			22	
Max. pressure	MPa	35	35	35	35	35	35	30	30	30	28	
Max. relief valve setting	MPa	38										
Standard boost pressure ⁽²⁾	MPa	0,6 (Mechanical Control) 2 (Hydraulic / Electric Servo Control)										
Suction pressure	MPa (assoluta)	> = 0,08										
Max. case pressure	MPa	0,15										
Min. shaft speed	n/min	500										
Rated speed	n/min	3.600									2900	
Max. speed	n/min	3.900									3200	
Max. oil temperature	°C	80										
Oil viscosity	cSt	15-35										
Fluid contamination		18/15/12 ISO 4406 (NAS 7)										
Dry weight (single pump) ⁽³⁾	kg	11										
Dry weight (tandem pump) ⁽³⁾	kg	23										

(1) 3.600 n/min 21 MPa

(2) 1.000 n/min

(3) Nominal data, weight varies depending on configuration and optional

SYSTEM DESIGN PARAMETERS

HYDRAULIC MEASURE	USEFUL FORMULAS	CONVERSION FACTORS
Flow rate: Q = (l/min)	$Q = V [\text{cm}^3/\text{n}] \times \eta_v \times n \cdot 10^{-3}$	1 l/min = 0,2641 US Gal/min
Pressure: P = (MPa)		1 MPa = 145 PSI
Displacement: V = (cm ³ /n)		
Torque: M = (Nm)	$M = \frac{\Delta p [\text{MPa}] \times V [\text{cm}^3/\text{n}]}{6.283 \times \eta_m}$	1 Nm = 8,851 in lbs
Power: P = (kW)	$P = \frac{\Delta p [\text{MPa}] \times V [\text{cm}^3/\text{n}] \times n}{60 \times 1000 \times \eta_t}$	1 KW = 1,36 HP
Shaft speed: n = n/min		
Hydraulic efficiency: = η_v		
Mechanical efficiency: = η_m		
Overall efficiency: = η_t		
		1 mm = 0,0394 in
		1 kg = 2,205 lbs
		1 N = 0,2248 lbs

PERFORMANCE DIAGRAM

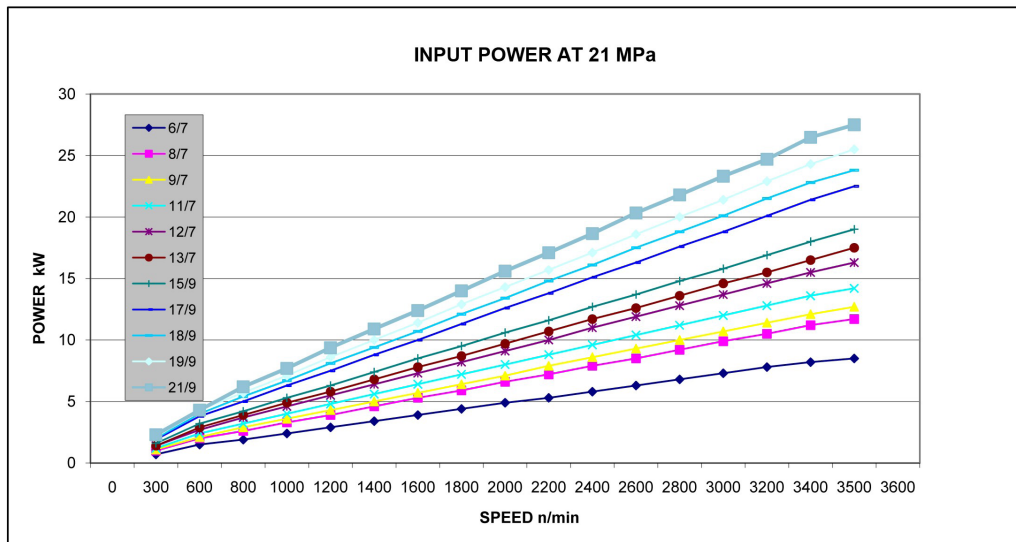
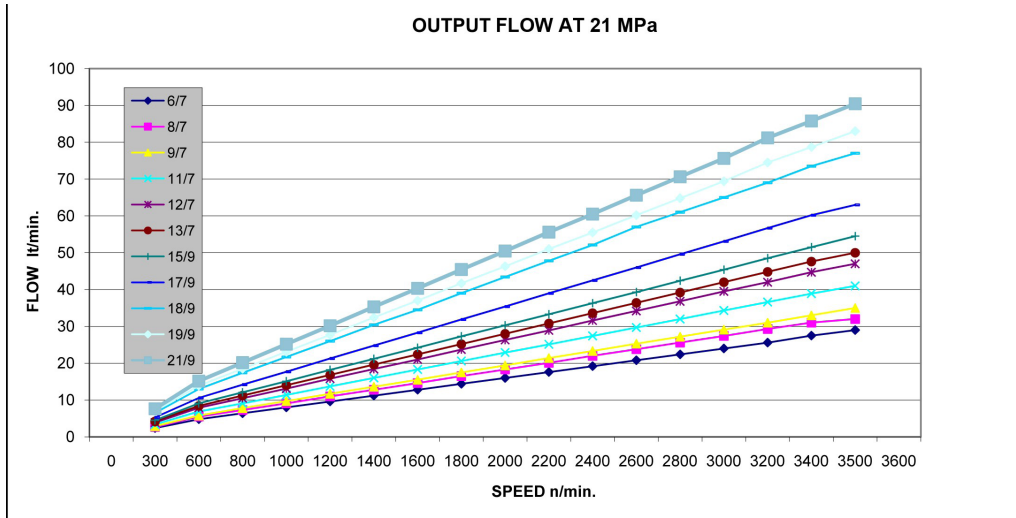

Performance diagrams

- The diagrams show the data of maximum speed and maximum continuous pressure.
- Data may vary depending on pump displacement.

- **Maximum speed:** is the maximum permissible speed for the pump for short periods and not fully loaded. The use of the pump with this speed can reduce the life cause a loss of power or hydrostatic braking capacity.

Pressure

- **Continuous pressure:** is the average pressure for continuous work, which must not be exceeded, to ensure a correct and long lasting service of the pump.
- **Maximum pressure:** is the maximum allowable pressure for short periods and must never be exceeded.

Caution

Any damage caused to the pump can reduce or eliminate the hydrostatic braking capacity. It is therefore necessary to provide an auxiliary braking system capable of stopping and supporting the weight of the complete machine, in the event of loss of hydrostatic power.

Speed

- **Continuous work speed:** is the maximum recommended speed for continuous operation of the pump under full load.

TORQUE CALCULATION

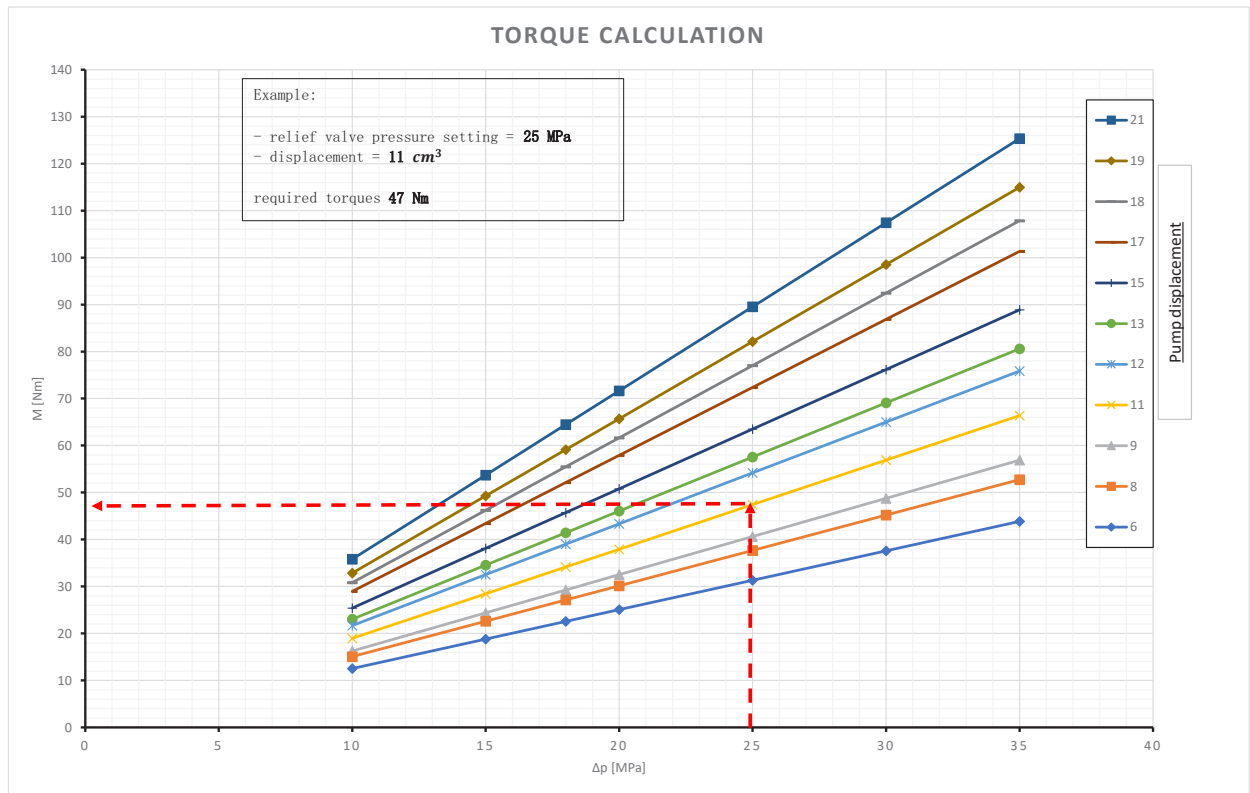

For a correct selection of the product, it is necessary to verify that the selected shaft is able to guarantee the mechanical resistance to the specific operating conditions.

The check involves comparing the torque value reached in the heaviest working condition with the one allowed by the pump shaft.

For multiple pump, is necessary to consider the sum of the torques required for each pump units.

The displacements and the working pressures for each unit are required for the verification. With these data is possible to calculate analytically or through the use of graph, the total torque required to the shaft.

The following equation shows the torque value:

$$M [Nm] = \sum_{i=1}^k \frac{V_i \left[\frac{cm^3}{n} \right] \cdot \Delta p_i [MPa]}{2 \cdot \pi \cdot \eta_m}$$

V_i = i pump displacement i, expressed in cm³;

Δp_i = i pressure difference between pump inlet and outlet, expressed in bar;

η_m = mechanical efficiency that we can assume equal to 0,94;

k = number of pumps.

INSTALLATION INSTRUCTIONS

Standards for the installation, start up and maintenance

- When mounting the pump above the minimum level of the tank, distance of the highest point of the pump over the oil level **MUST NOT** exceed 250 mm.
- To reduce the noise level typical of all piston pumps we recommend:
 - use hoses instead of pipes
 - limit to a minimum the length of eventual pipes
 - fix rigid pipe sections with special supports equipped with rubber vibration dampening devices
 - use pipes and hoses with a diameter according to the speed values below:

Suction line = $0,6 \div 1,2 \text{ m / s}$

Drain = $1,5 \div 3,6 \text{ m / s}$

Pressurized lines = max 6 m / s

- To calculate the speed of the oil in the lines refer to the formula below:

$$V = (Q * 21,22) / D$$

V = speed (m/s)

Q = flow rate (l/min)

D = internal pipe/hose diameter (mm)

- In any case **NEVER** use pipes/hoses or fittings with diameter smaller than that of the corresponding ports on the pump. This indication is **ABSOLUTELY OBLIGATORY** for the drain line to avoid to pressurize the pump housing and extrude the lip seal of the pump shaft.
- During mounting cure the alignment of the pump, concentric with the drive shaft sleeve to prevent overloading of the bearing.
- For the hydraulic system, we recommend using pipes/hoses washed internally with hydraulic oil or, even better, with solvent.
- Special care must be taken when cleaning the inside of the tank (painting is recommended after sand blasting).
- To improve the functionality of the boost pump, it is recommended to place it below minimum tank level.
- The pumps can be installed in any direction and position.
For further information contact our Technical Department.

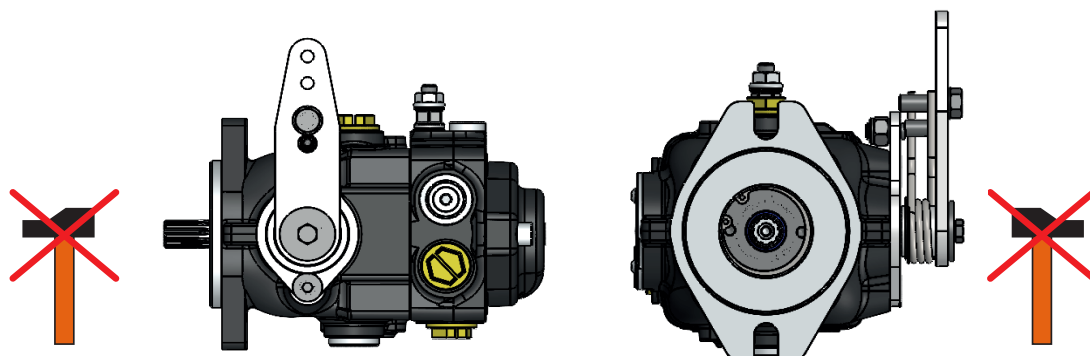

(continued)

INSTALLATION INSTRUCTIONS

Shaft Coupling

To connect the pump shaft to the engine flywheel or prime motor shaft use a flexible

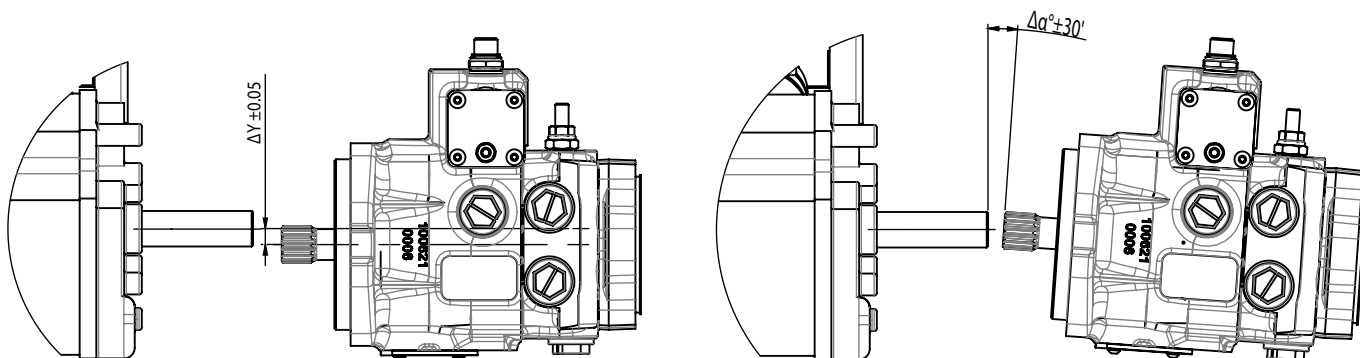

coupling. The alignment must be within the tolerances indicated in the figures below.

For an optimal function of the pump the shaft should not be subjected to radial or axial loads. In the presence of radial and axial loads the maximum allowable values are shown below.

During the installation or removal, do not force the coupling of the pump shaft, but always use the threaded hole on the shaft.

Start up

- Before starting fill the tank and the other components with new filtered oil. You should run a flushing of the complete hydraulic system (see Use and Maintenance Manual). Check that the low pressure value is correct (refer to the Use and Maintenance Manual).
- Restore the oil level in the tank.

Maintenance

- The first oil change should be made after 500 hours of operation. Later change the oil every 2000 hours.
- The first replacement of the filter cartridge has to be made after 50 hours for a preliminary circuit cleaning. Then after further 500 hours.

- These frequencies have to be reduced in the case where the indicator shows the clogging of the filter cartridge and in case of operation in environments with a high level of contamination.

CAUTION

- Always work with the utmost attention to the moving parts; do not use loose or fluttering clothing.
- Do not approach rotating wheels, tracks, chains or shafts if not properly protected, or when they may start moving without notice.
- Do not loosen or disconnect fittings and pipes/hoses while the engine is running.
- Avoid oil leaks in order to prevent environmental pollution.

Load capacity of rear shaft (through drive shaft)

- The rear shaft is not able to carry radial loads.

HYDRAULIC FLUID

Viscosity

The maximum duration and the maximum efficiency are related to the optimum range of viscosity.

Viscosity = optimal operating viscosity 15 ÷ 40 cSt referred to the temperature of the closed circuit.

Minimum viscosity = 10 cSt for short moments and with the maximum temperature of the drain oil at 90 °C.

Max. viscosity = 1000 cSt for a few seconds, only during cold starting.

Working conditions

For working conditions apply the following limits:

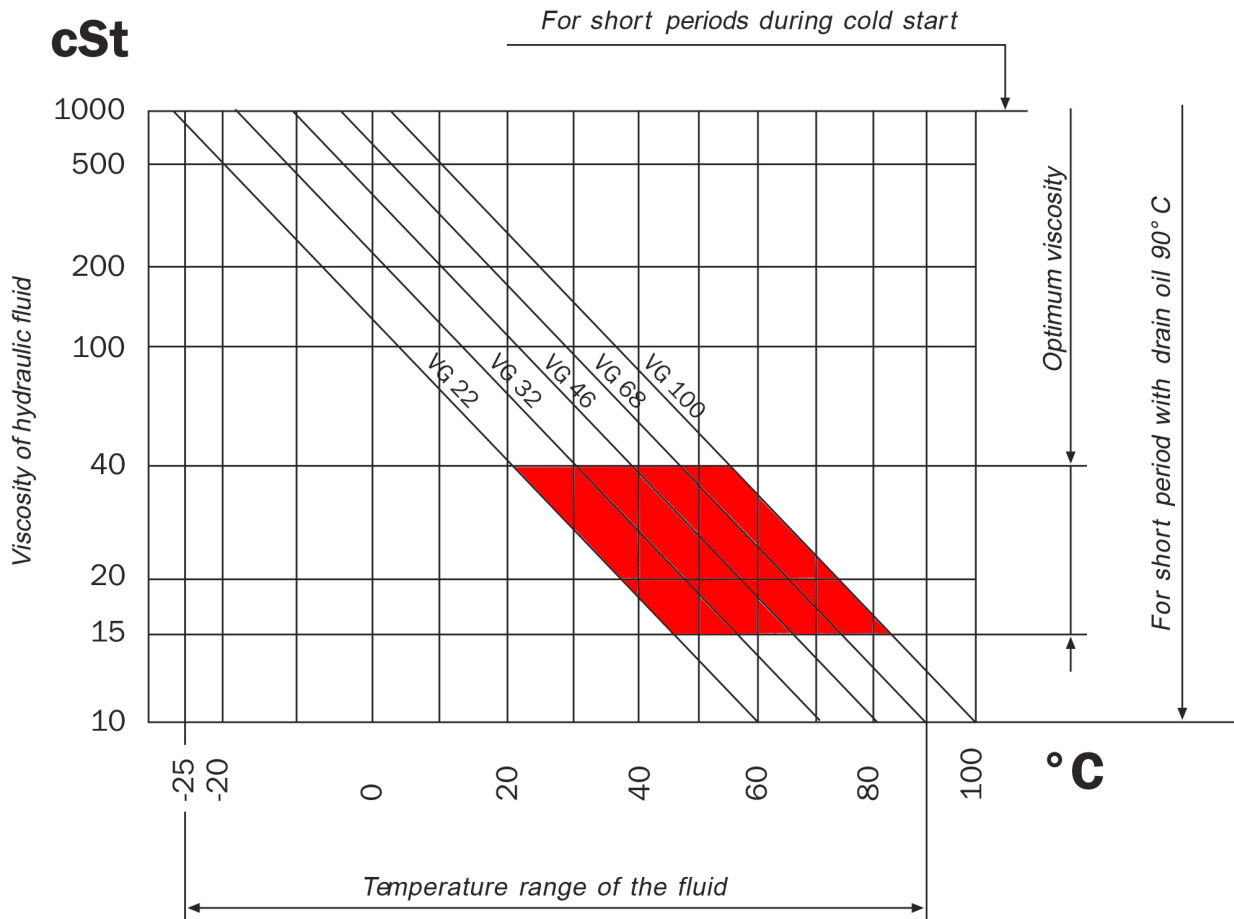

HANSA - TMP cannot be held responsible concerning non compliance of these instructions and observance of safety regulations, although not covered by this document.

HYDRAULIC FLUID FILTRATION

The contaminating particles suspended in the hydraulic fluid cause the wear of the hydraulic mechanisms moving parts.

On hydraulic pumps these parts operate with very small dimensional tolerances.

In order to prolong the parts life, it is recommended to use a filter that maintains the hydraulic fluid contamination class at max.

8 according to NAS 1638
5 according to SAE, ASTM, AIA
19/17/14 according to ISO 4406

According to the type of application decided for the pump, it is necessary to use filtration elements with a filtration ratio of:

$$\beta_{(x)} 20 \div 30 \geq 75$$

making sure that this ratio does not worsen together with the increasing of the filter cartridge differential pressure. While the pump is working, its temperature increases (over 80° to 110°C) with negative effects on pump performances; as a consequence, it is important to observe a max. contamination level of:

7 according to NAS 1638
4 according to SAE, ASTM, AIA
18/16/13 according to ISO 4406

If these values cannot be secured, the component life will consequently be reduced and it is recommended to contact our Tech. Dept.

Suction filters

The suction filters will have a clogging indicator and bypass. The max. pressure drop of the filtration element must not exceed 0,04 absolute MPa (0,08 absolute MPa with cold start).

Filter assembling

The suction filter is mounted in the suction line. Check that the pressure before the boost pump is 0,08 absolute bar, measured on the pump suction port (0,05 MPa for cold starting).

ORDER CODE

0	1	2	3	4	5	6	7	8	9	10	11	12	13	14	15	16	17	18
TPV/TPVS	1100	06	CR	SS2	B	F1	SHI	OAL	20	04	20	000	B2	000	0	00	G	00
TPVT2		06 06					SHI SHI	OAL OAL	20 20									
TPVT3		06 06 06					SHI SHI SHI	OAL OAL OAL	20 20 20									

Pag.

- 0 - Pump Model**
- TPV = Closed loop circuit single pump
- TPVS = Closed loop circuit special single pump on customer request
- TPVT2 = Closed loop circuit tandem pump
- TPVT3 = Closed loop circuit triple pump

- 1 - Pump Series**
- 1100 = Pump Series 1100 (ex TPV 1000)

- 2 - Pump displacement**
- 6 = 7,4 cm³/n 8 = 8,9 cm³/n 9 = 9,6 cm³/n 11 = 11,2 cm³/n
- 12 = 12,8 cm³/n 13 = 13,6 cm³/n 15 = 15 cm³/n 17 = 17,1 cm³/n
- 18 = 18,2 cm³/n 19 = 19,4 cm³/n 21 = 21,15 cm³/n

- 3 - Rotation**
- CR = Clockwise rotation (right)
- CC = Counter-clockwise rotation (left)

- 4 - Shafts**
- SS2 = Splined shaft Z9 - 16/32" D.P. 19
- SS3 = Splined shaft Z13 - 16/32" D.P. 19
- SS4 = Splined shaft Z11 - 16/32" D.P. 19
- PS1 = Parallel keyed shaft ø15.875 with key (Available only for single pump. Attention: check shaft drive torque for high displacements and pressures) 20
- PS3 = Parallel keyed shaft ø18 with increased bearing for external radial load 21

- 5 - Swashplate bearings**
- B = Bushings
- C = Needle roller bearing
- Attention: In case of displacement 21 cc with working pressure greater than or equal to 250 bar, select configuration B - SELF-LUBRICATING BUSHINGS

- 6 - Mounting flange**
- F1 = SAE-A 2 holes - pilot diam. 82,5 mm 22
- F2 = SAE-B 2 holes - pilot diam. 101,6 mm 22
(available only with servo-control SHI, SEI and shaft SS3) 22

- 7 - Pump controls**
- DM = Direct mechanical (without control lever) 23
- BC = Tapered bush 23
- LC = Direct Mechanical Control with Lever 24
- DMS = Control lever with return to zero position (torsion spring standard diameter 3,6 mm.) 25
- DMS (30) = Control lever with return to zero position (torsion spring diameter 3 mm.) 26
- DMS (33) = Control lever with return to zero position (torsion spring diameter 3,3 mm.)
- DMS (40) = Control lever with return to zero position (torsion spring diameter 4 mm.)
- DMS (50) = Control lever with return to zero position (torsion spring diameter 5 mm.)
- DMZ = Control lever with return to zero position (red compression spring) 28
- SHI = Integrated hydraulic servo control 30
- SHIC = Compact integrated hydraulic servo control 30
- SEI 1 = Integrated electro-proportional servo control 12V DC 32
- SEI 2 = Integrated electro-proportional servo control 24V DC 34
- SEI 1 D = Integrated electro-proportional servo control 12V DC DEUTSCH 34
- SEI 2 D = Integrated electro-proportional servo control 24V DC DEUTSCH 37

		DM	SHI	SEI	
F1	SS2	X	X	X	
	SS3	X	X	X	
	SS4	X	X	X	
	PS1	X	X	X	
	PS3	X	X	X	
F2	SS2	-	-	-	22
	SS3	-	X	X	22
	SS4	-	X	X	22
	PS1	-	-	-	
	PS3	-	X	X	23

(continued)

ORDER CODE

40

8 - Control devices position

- OA** = Upper position (STD)
OB = Lower position
 Device control LC, DMS e DMZ
LA = Left lever upper position
RA = Right lever upper position
LB = Left lever lower position
RB = Right lever lower position
 Device control SHI - SEI (all)
OAL = Upper servo position, left zero screw (STD)
OBL = Lower servo position, left zero screw
OAR = Upper servo position, right zero screw
OBR = Lower servo position, right zero screw

	OA	OB	LA	LB	RA	RB	OAL	OBL	OAR	OBR
DM	X	X								
BC	X	X								
LC			X	X	X	X				
DMS			X	X	X	X				
DMZ			X	X	X	X				
SHI							X	X	X	X
SEI							X	X	X	X

9 - Relief valve pressure setting

- 10** = 10 MPa **15** = 15 MPa **18** = 18 MPa
20 = 20 MPa **25** = 25 MPa **30** = 30 MPa
35 = 35 MPa

10 - Boost pump

- 00 (yy)** = Without boost pump [indicate pressure (xx) and flow rate (yy)]
01 (yy) = Without boost pump in compact B1-B2 version [indicate pressure (xx) and flow rate (yy)]
04 = Boost pump STD C-B1-B2 (3.9 cm³/rev), SA (4.7 cm³/rev)

For pressures other than STD, required between 0.5 MPa and 3 MPa MAX (calibration carried out at 1000 rpm).

If in doubt contact our technical department.

	00	01	04	
			3,9 cm ³ /rev	4,7 cm ³ /rev
C	X		X	
B1	X	X	X	
B2	X	X	X	
SA	X			X

11 - Boost pressure

- 05** = 0.5 MPa **06** = 0.6 MPa (1) **07** = 0.7 MPa **08** = 0.8 MPa
09 = 0.9 MPa **10** = 1.0 MPa **11** = 1.1 MPa **12** = 1.2 MPa
13 = 1.3 MPa **14** = 1.4 MPa **15** = 1.5 MPa **16** = 1.6 MPa
17 = 1.7 MPa **18** = 1.8 MPa **19** = 1.9 MPa **20** = 2.0 MPa (2)
21 = 2.1 MPa **22** = 2.2 MPa **23** = 2.3 MPa **24** = 2.4 MPa
25 = 2.5 MPa **26** = 2.6 MPa

Note: Boost pressures are recorded at 1000 n/min

Note 1: STD for DM-BC-LC-DMS-DMZ control pumps

Note 2: STD for SHI-SEI control pumps

12 - Boost flow rating

000= Like boost pump

Only for pumps with external charge

- 025**= 2,5 l/min **070** = 7 l/min **130** = 13 l/min **220** = 22 l/min **310** = 31 l/min
030= 3 l/min **075** = 7,5 l/min **140** = 14 l/min **230** = 23 l/min **320** = 32 l/min
035= 3,5 l/min **080** = 8 l/min **150** = 15 l/min **240** = 24 l/min **330** = 33 l/min
040= 4 l/min **085** = 8,5 l/min **160** = 16 l/min **250** = 25 l/min **340** = 34 l/min
045= 4,5 l/min **090** = 9 l/min **170** = 17 l/min **260** = 26 l/min
050= 5 l/min **095** = 9,5 l/min **180** = 18 l/min **270** = 27 l/min
055= 5,5 l/min **100** = 10 l/min **190** = 19 l/min **280** = 28 l/min
060= 6 l/min **110** = 11 l/min **200** = 20 l/min **290** = 29 l/min
065 = 6,5 l/min **120** = 12 l/min **210** = 21 l/min **300** = 30 l/min

WARNING: For red flow rate, contact our technical department.

(continued)

ORDER CODE

	13 - Cover/rear mounting flange	
C	= Closed cover	43
B1	= For German standard pump GR1 mounting (pilot flange ø32)	43
B2	= For German standard pump GR2 mounting (pilot flange ø52)	44
SA	= Version SAE A 2+2 holes Z.9 16/32" D.P.	45
SA-C	= Version SAE A 2+2 holes Z.9 16/32" D.P. + Closed cover	46

14 - Gear pump displacements (also available multiple gear pumps e.g. 204+117)
Group 1

112 = 1,2 cm ³ /n	117 = 1,7 cm ³ /n	122 = 2,1 cm ³ /n	126 = 2,6 cm ³ /n
132 = 3,1 cm ³ /n	138 = 3,6 cm ³ /n	143 = 4,2 cm ³ /n	149 = 4,9 cm ³ /n
159 = 5,9 cm ³ /n	165 = 6,5 cm ³ /n	178 = 7,5 cm ³ /n	

Group 2

204 = 4,2 cm ³ /n	206 = 6,0 cm ³ /n	209 = 8,4 cm ³ /n	211 = 10,8 cm ³ /n
214 = 14,4 cm ³ /n	217 = 16,8 cm ³ /n	219 = 19,2 cm ³ /n	222 = 22,8 cm ³ /n
226 = 26,2 cm ³ /n			

Group 2 (SAE-A)

S204 = 4,2 cm ³ /n	S206 = 6,0 cm ³ /n	S209 = 8,4 cm ³ /n	S211 = 10,8 cm ³ /n
S214 = 14,4 cm ³ /n	S217 = 16,8 cm ³ /n	S219 = 19,2 cm ³ /n	S222 = 22,8 cm ³ /n
S226 = 26,2 cm ³ /n			

Attention: For GR 1 pumps, GAS ports is standard; for GR 2 pumps flanged is standard

	15 - Gear pumps connections	42
0	= Without gear pump	
F	= Connection with holes for flange	42
G	= Connection with GAS holes (BSPP)	42

	16 - Optional	47
00	= Without optional	
LB	= Lever by-pass	47
VS	= Flushing valve	48
VSLB	= Lever by-pass + Purge Valve	49
SB	= Screw by-pass (not possible with optional SA and SA.C)	50
SB (0.8)	= Perforated screw by-pass ø0.8 for DMS control pumps (not possible with optional SA and SA.C)	
ST	= Conversion coupling from 9 teeth to 13 teeth	51
FB	= Conversion flange from SAE-A to SAE-B	51
FBST	= Conversion flange from SAE-A to SAE-B + Conversion shaft 9 teeth to 13 teeth	52

17 - Ports

Combination		S	A-B	T-T1	P1-P2	Ma-Mb	IN-OUT	G
		Suction	Ports	Tanks	Pilot	Pressure connection	Remote filter connection	Suction pressure connection
G	GAS Ports (STD)	1/2" BSPP	1/2" BSPP	1/2" BSPP	1/4" BSPP	1/4" BSPP	3/8" BSPP	1/4" BSPP
U	UNF Ports (1)	7/8-14 UNF	7/8-14 UNF	7/8-14 UNF	9/16-18 UNF	9/16-18 UNF	7/8-14 UNF	9/16-18 UNF

Note 1: Only on request and minimum quantity of 50 pieces.

	18 - Restrictor on servo control (only SHI and SEI versions)	
00	= Without restrictor	
06	= Restrictor orifice ø0,6 mm	
07	= Restrictor orifice ø0,7 mm	
08	= Restrictor orifice ø0,8 mm	
10	= Restrictor orifice ø1,0 mm	
12	= Restrictor orifice ø1,2 mm	

SINGLE PUMP

(Direct mechanical control - overall dimensions)

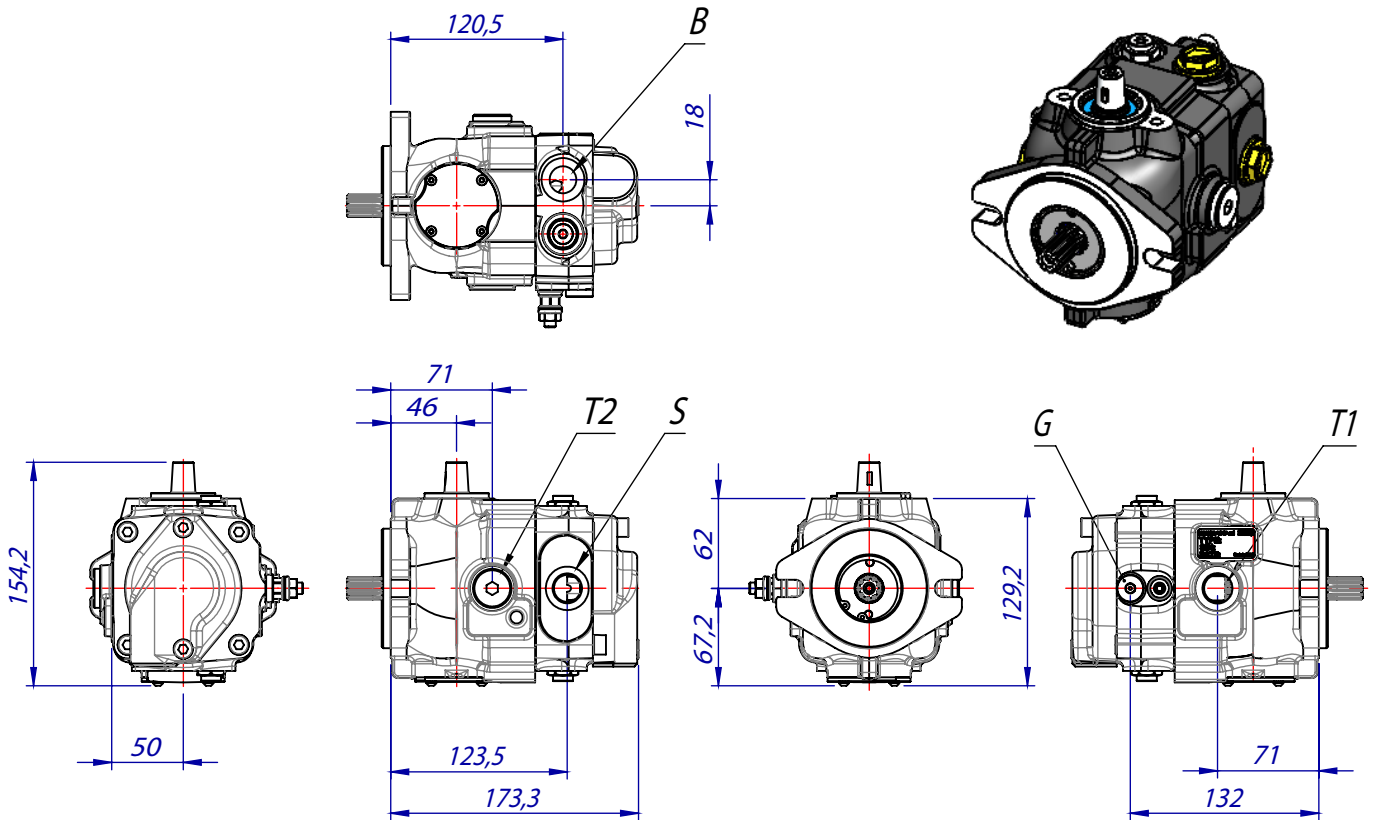

PIPE CONNECTIONS		
A - B	Main ports	1/2" BSPP
T1 - T2	Drain	1/2" BSPP
S	Suction	1/2" BSPP
G	Pressure connection	1/4" BSPP

HYDRAULIC CIRCUIT

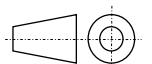
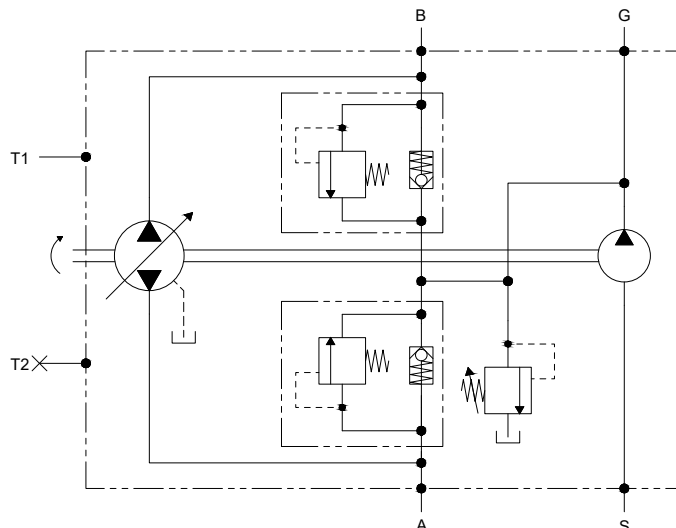

TANDEM PUMP WITH SHI CONTROL

(Overall dimensions)

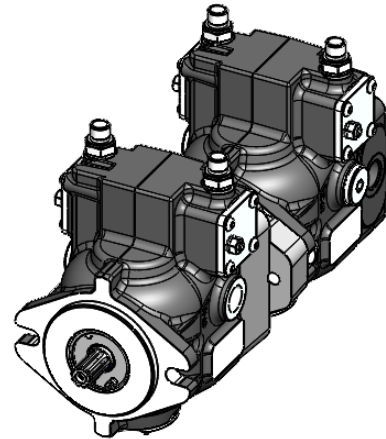
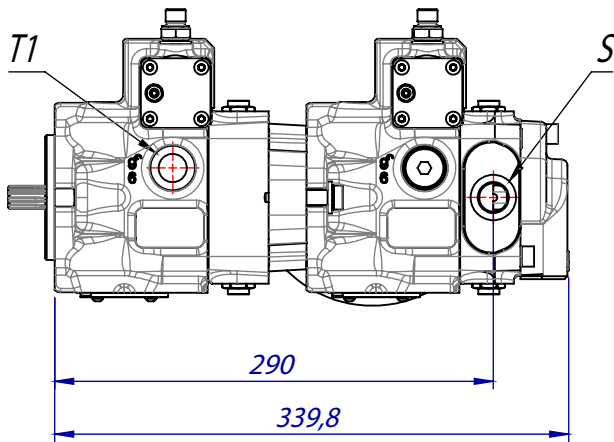

PIPE CONNECTIONS		
A1 - B1	Pump connections 1	1/2" BSPP
A2 - B2	Pump connections 2	1/2" BSPP
T1-T2	Drain	1/2" BSPP
S	Suction	1/2" BSPP
P1-P2	Servo control ports	1/4" BSPP
P3-P4		
G	Boost gauge	1/4" BSPP

For technical specifications, please refer to single pump.

HYDRAULIC CIRCUIT

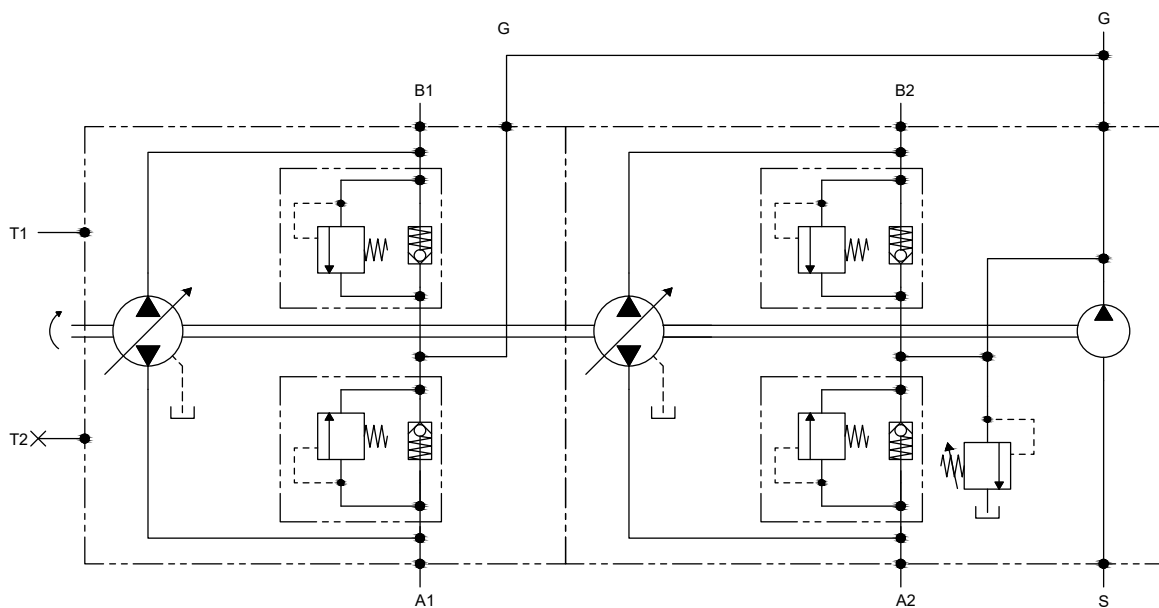

TRIPLE PUMP WITH SHI CONTROL

(Overall dimensions)

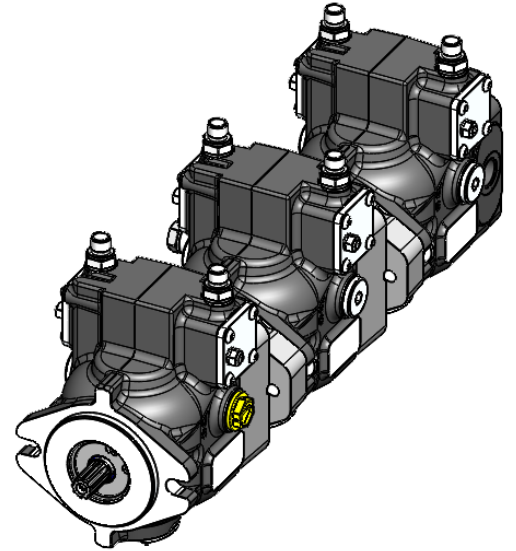
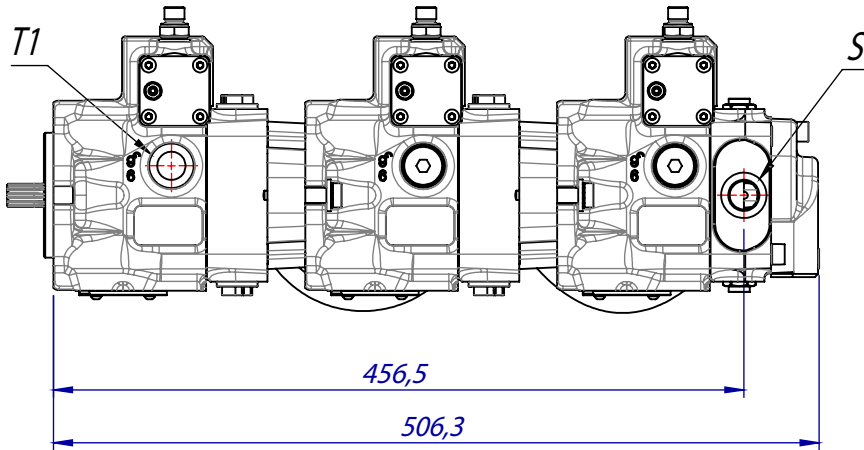

PIPE CONNECTIONS		
A1 - B1	Main ports	1/2" BSPP
A2 - B2		
A3 - B3		
T1-T2	Drain	1/2" BSPP
S	Suction	1/2" BSPP
P1-P2	Servo control ports	1/4" BSPP
P3-P4		
P5-P6		
G	Boost gauge	1/8" BSPP

For technical specifications, please refer to single pump.

HYDRAULIC CIRCUIT

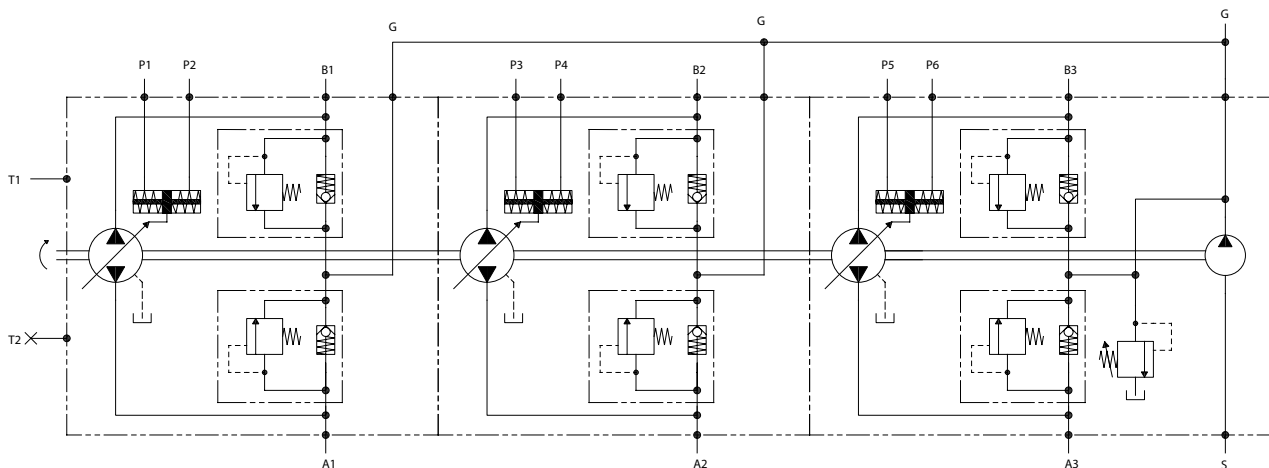

SHAFTS

SS2

SPLINED SHAFT Z=09 16/32 DP

ANSI standard B92.2-1970 CLASS 5

Max. torque = 120 Nm

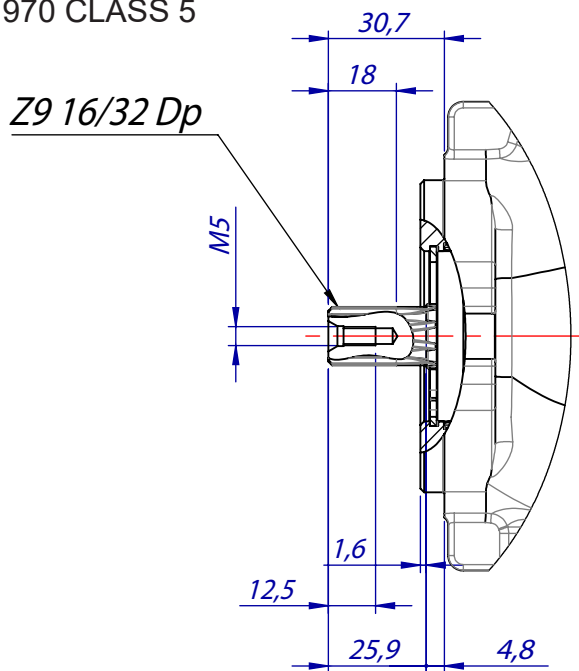

SS3

SPLINED SHAFT Z=13 16/32 DP

ANSI standard B92.2-1970 CLASS 5

Max. torque. = 320 Nm

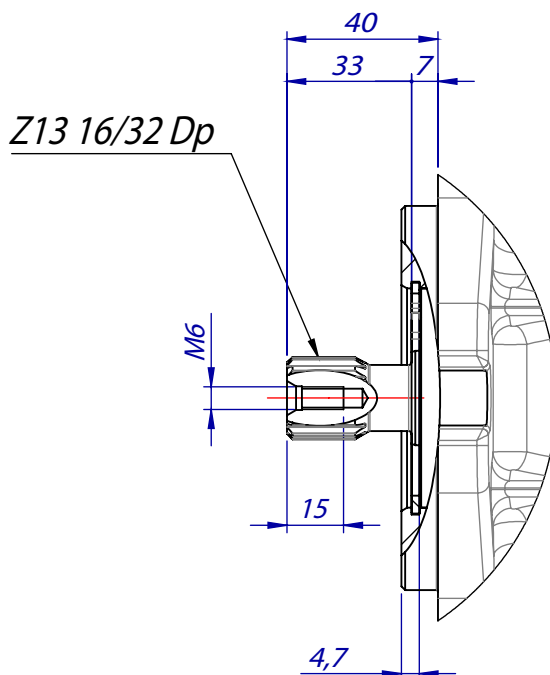

(continua)

SHAFTS

SS4

SPLINED SHAFT Z=11 16/32 DP

ANSI standard B92.2-1970 CLASS 5

Max. torque = 160 Nm

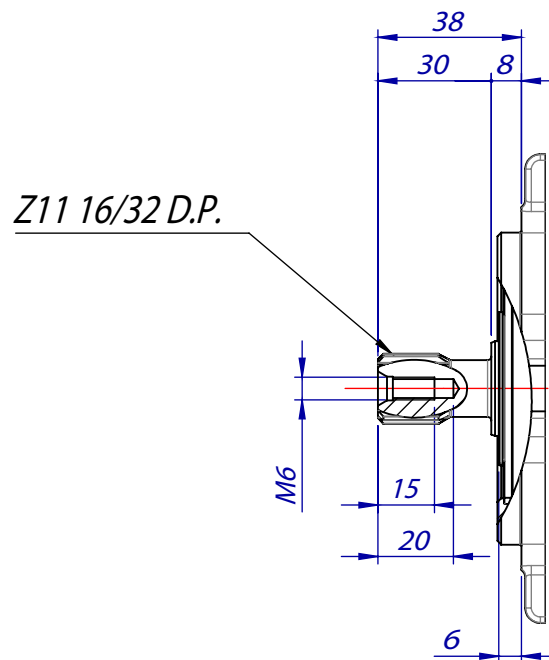

SHAFTS

PS1

PARALLEL KEYED SHAFT DIAM. 15.875

Max. torque = 65 Nm

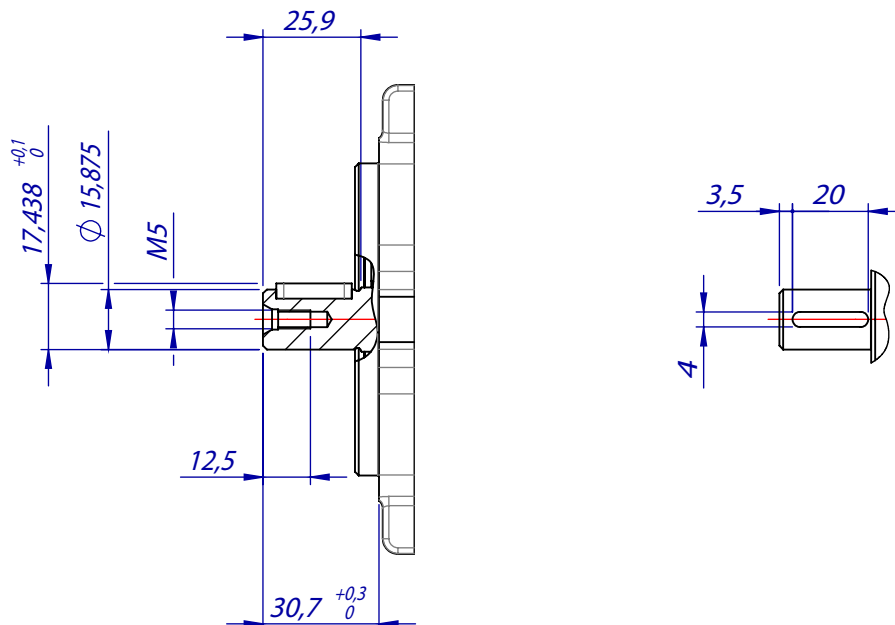

PS3

PARALLEL KEYED SHAFT DIAM. 18

Max. torque = 85 Nm

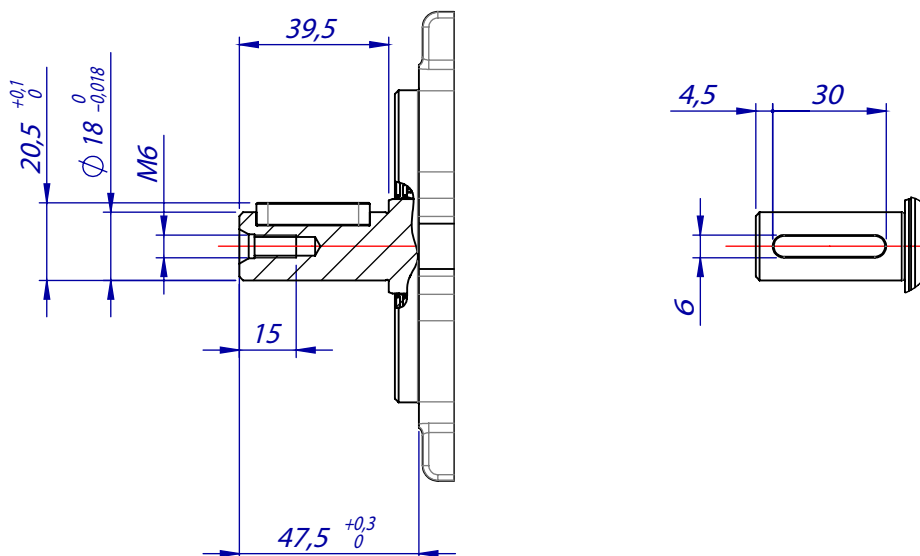

MOUNTING FLANGES

F1

SAE-A - 2 HOLES FLANGE

ISO 3019 - 1:2000

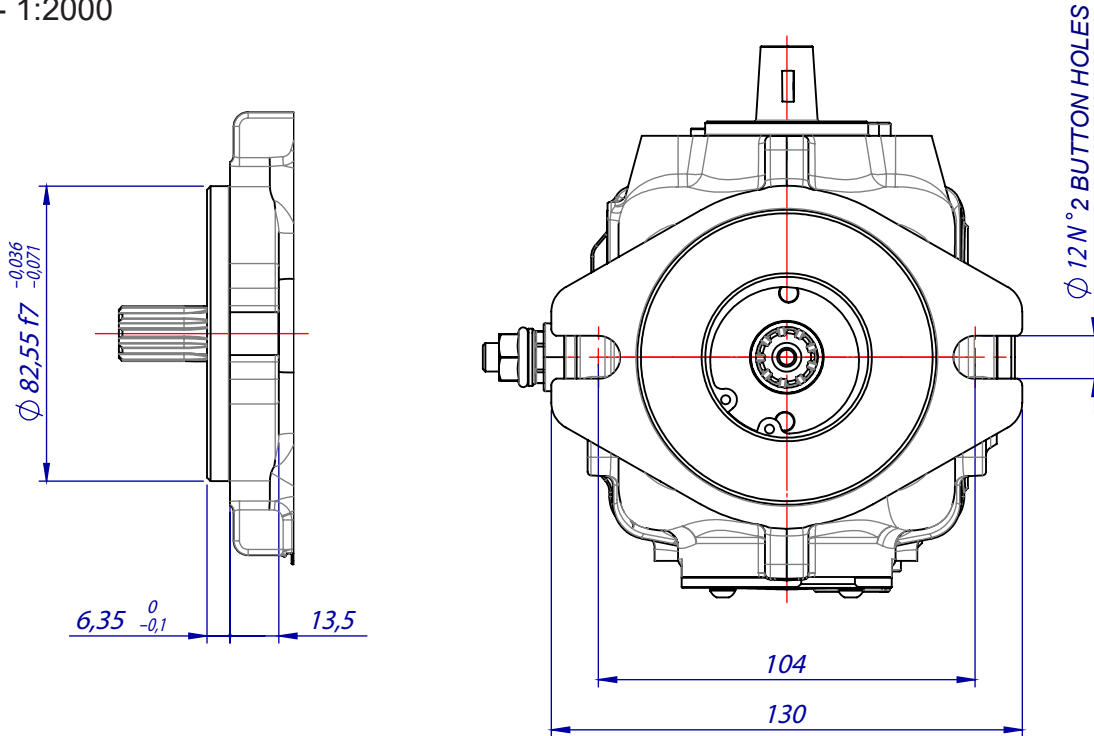

F2

SAE-B - 2 HOLES FLANGE

ISO 3019 - 1:2000

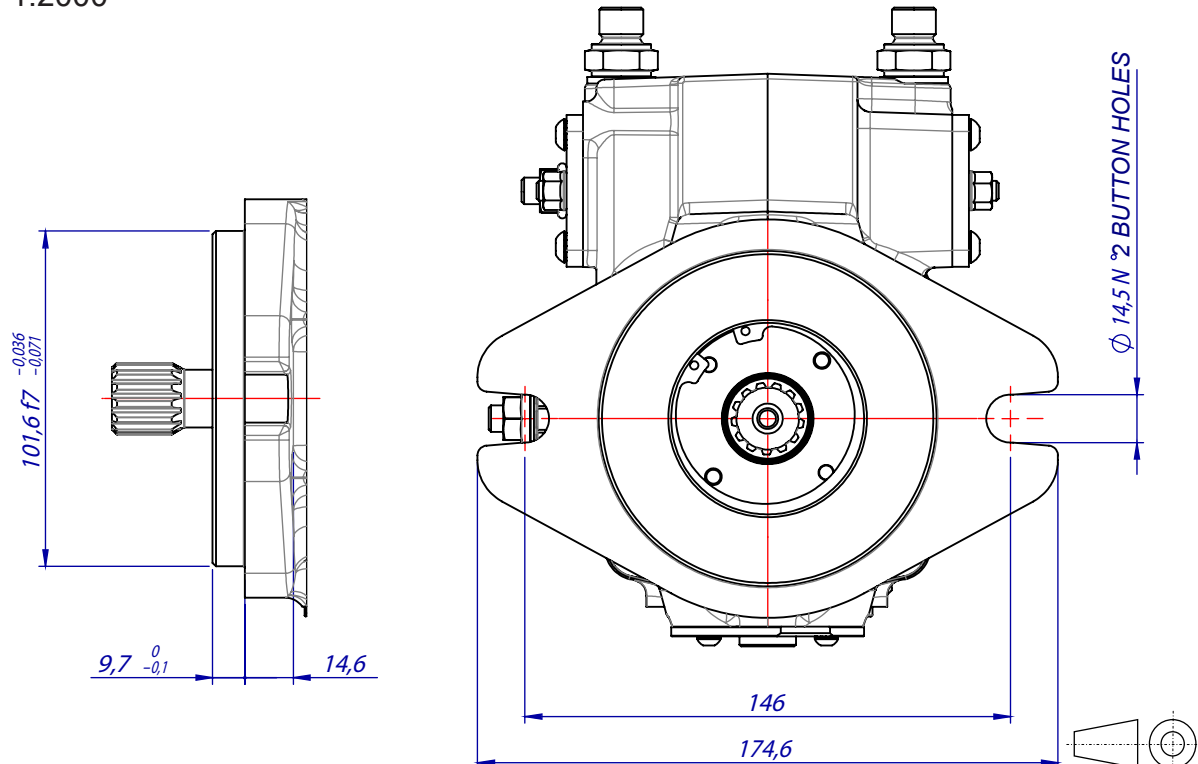

DM

DIRECT MECHANICAL WITHOUT CONTROL LEVER

The change of pump displacement is given by clockwise or counter-clockwise rotation of the shaft of the swashplate.

The shaft is directly linked with the swashplate.

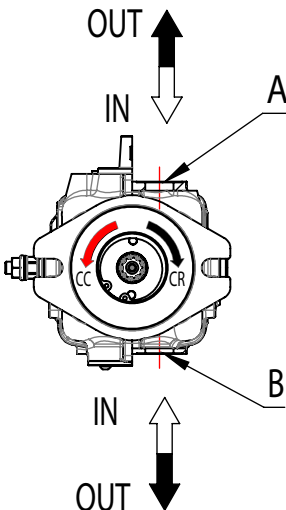
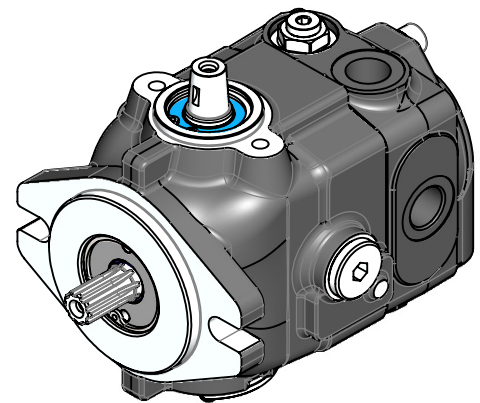
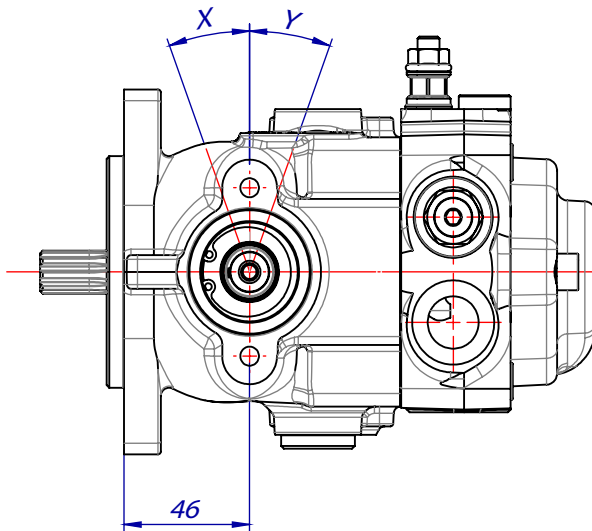
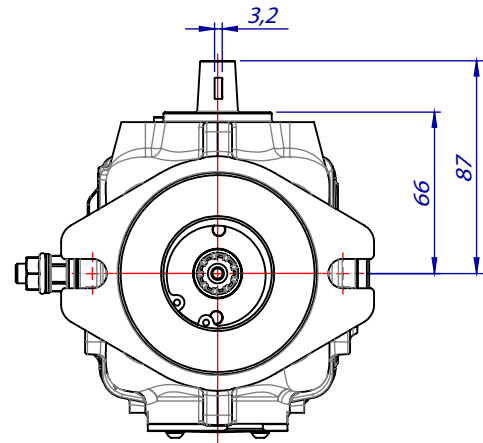
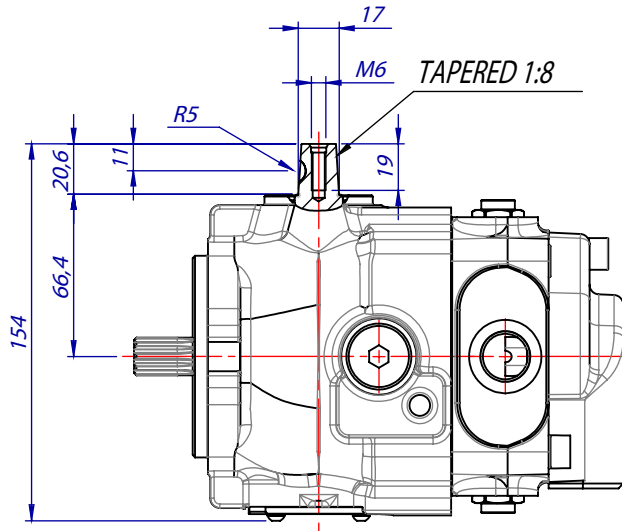

FLOW DIRECTION	PUMP		
	Lever position	OUT	IN
Pump rotation			
Clockwise CR	X	A	B
	Y	B	A
Counter-clockwise CC	X	B	A
	Y	A	B

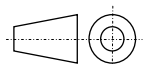

BC
TAPERED BUSH

Tapered bush with Woodruff key UNI 6606, external cylindric.
Suitable for arrangement of specific control levers.

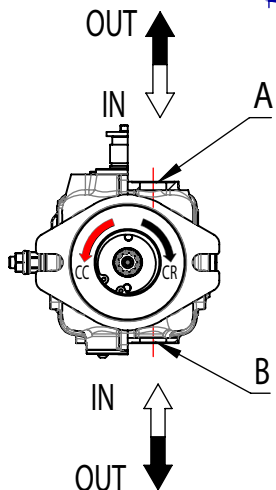
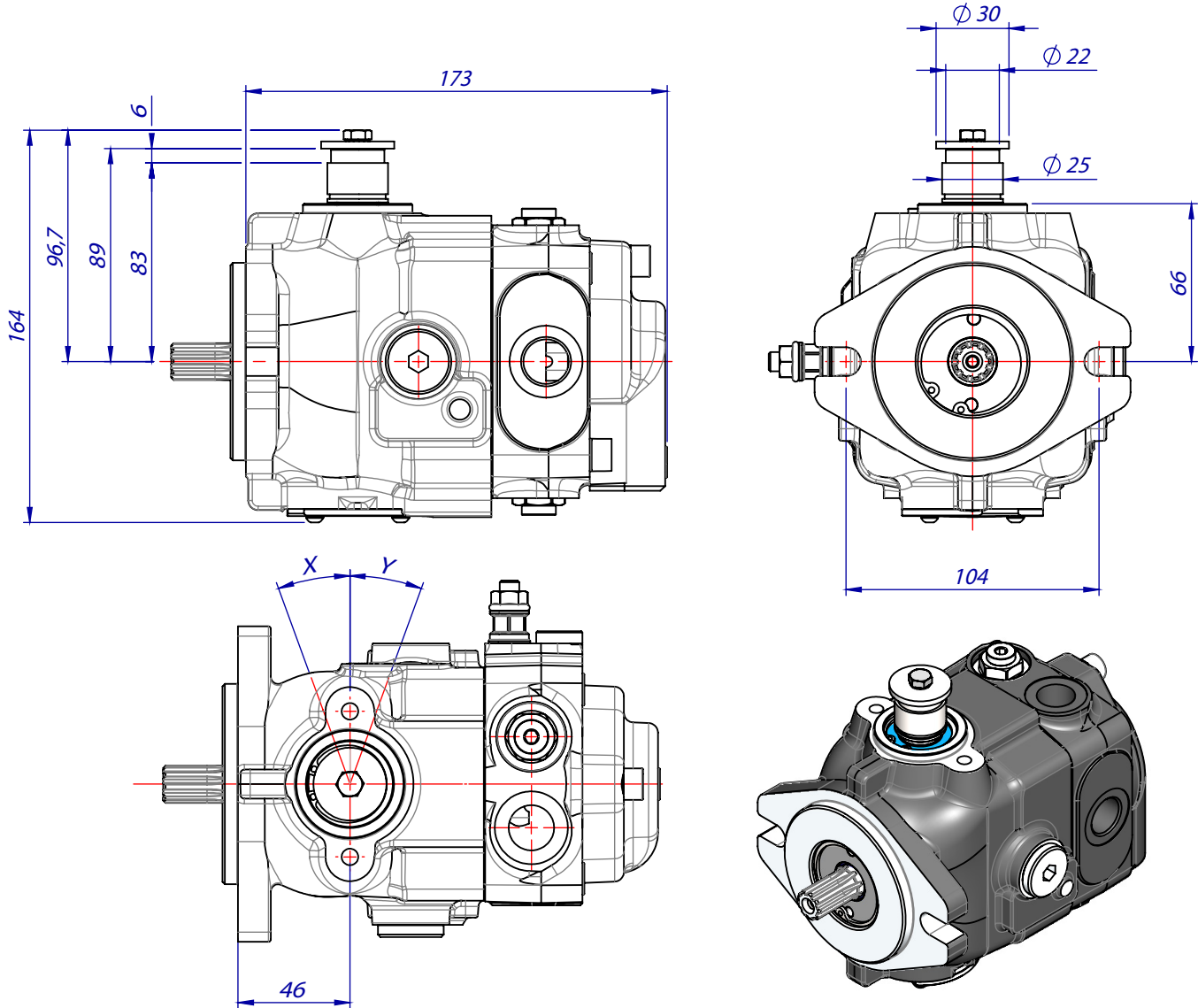

FLOW DIRECTION	PUMP		
	Lever position	OUT	IN
Pump rotation			
Clockwise CR	X	A	B
	Y	B	A
Counter-clockwise CC	X	B	A
	Y	A	B

LC

DIRECT MECHANICAL CONTROL WITH LEVER

The pump displacement variation is given by clockwise or counter-clockwise movement of the lever. The lever shaft is directly linked to the swashplate.

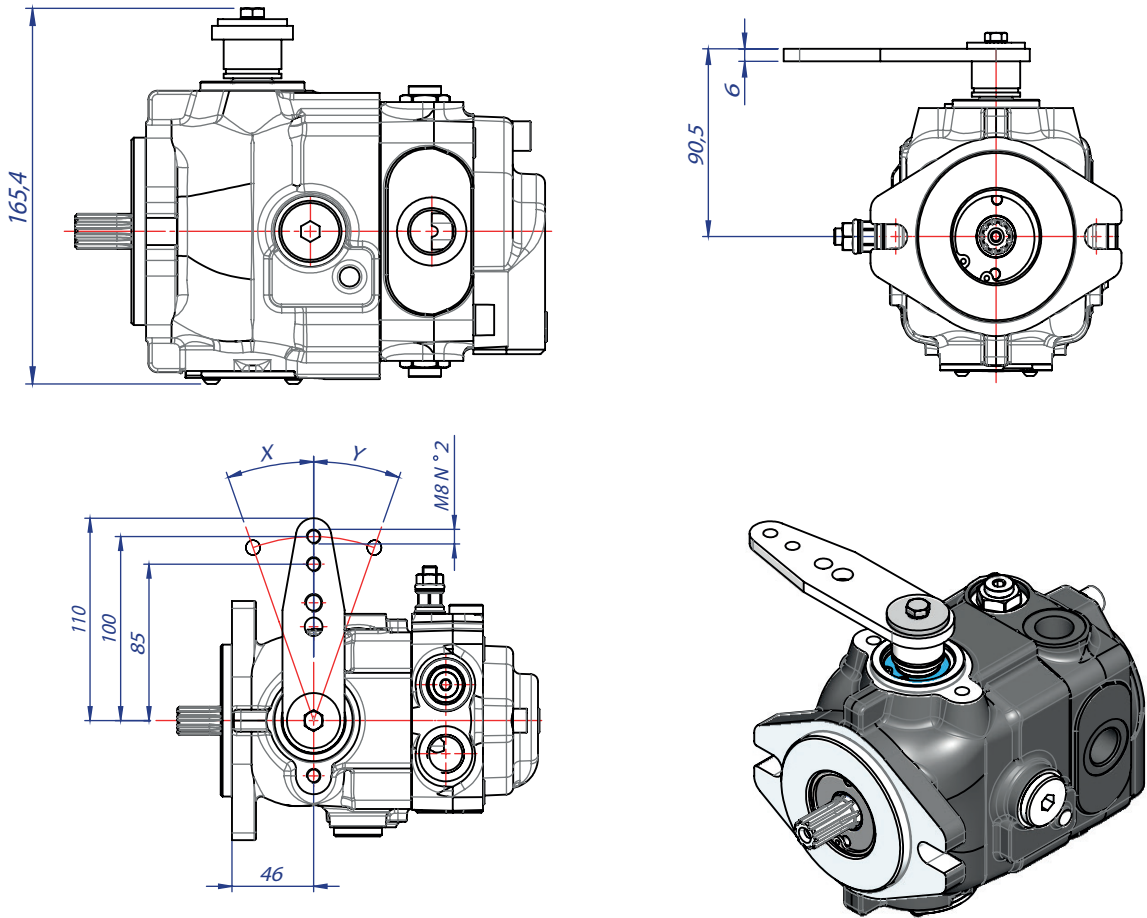

Lever Angle											
Pump Model	6 / 7	8 / 7	9 / 7	11 / 7	12 / 7	13 / 7	15 / 9	17 / 9	18 / 9	19 / 9	21 / 9
Lever Angle (X - Y)	10°	12°	13°	15°	17°	18°	15°	17°	18°	19°	19°

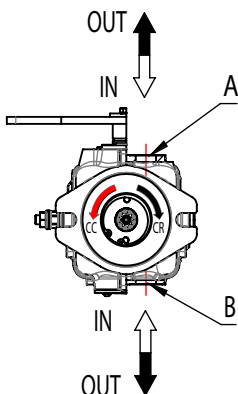

FLOW DIRECTION	PUMP		
	Lever position	OUT	IN
Pump rotation			
Clockwise CR	X	A	B
	Y	B	A
Counter-clockwise CC	X	B	A
	Y	A	B

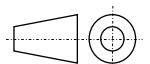

DMS

CONTROL LEVER WITH RETURN TO ZERO FLOW POSITION

(torsion spring)

The pump displacement variation is given by a clockwise or counter-clockwise movement of the lever. Return to zero flow is obtained by a spring which is part of the leverism. The lever shaft is directly linked to the swashplate.

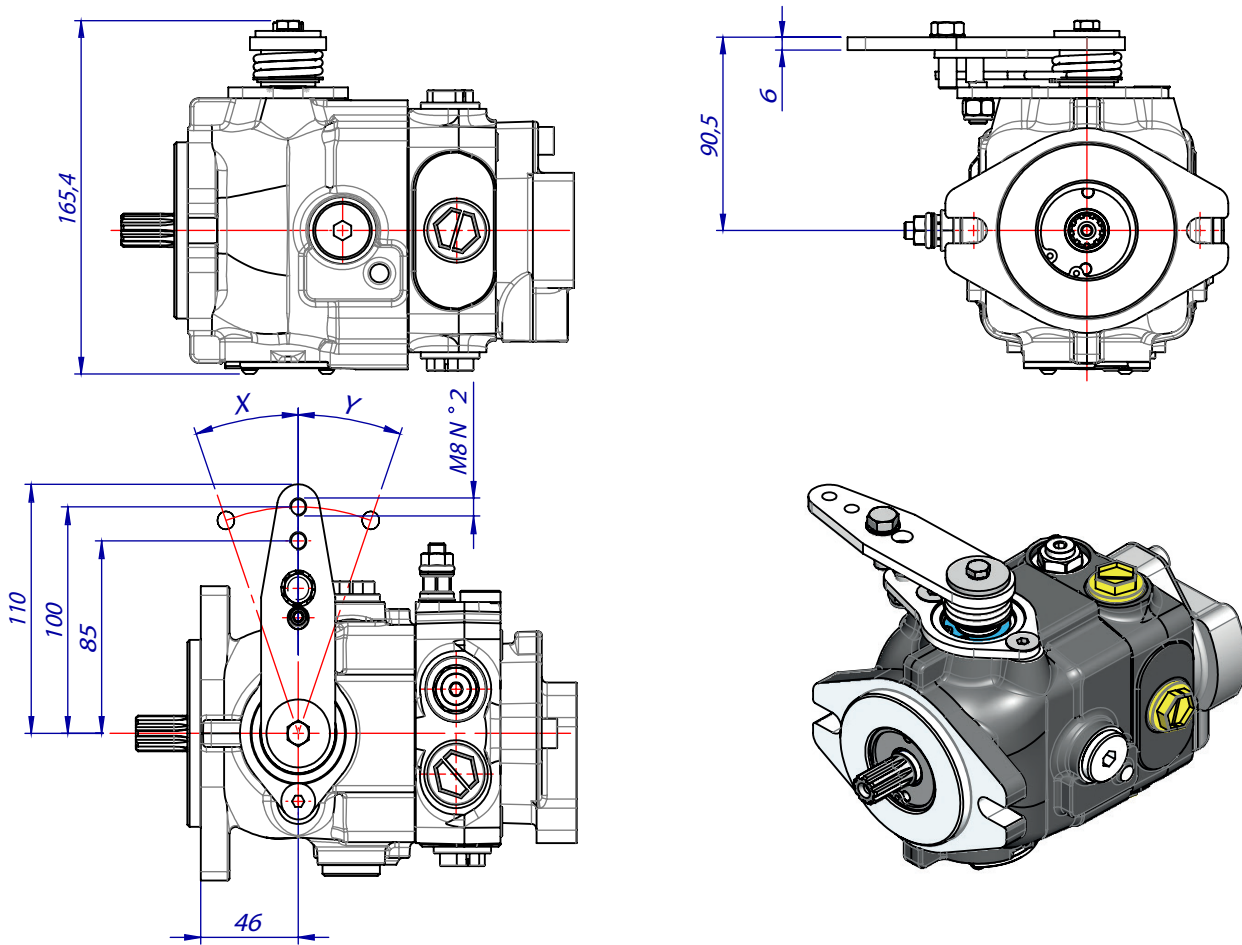

Lever Angle

Pump Model	6 / 7	8 / 7	9 / 7	11 / 7	12 / 7	13 / 7	15 / 9	17 / 9	18 / 9	19 / 9	21 / 9
Lever Angle (X - Y)	10°	12°	13°	15°	17°	18°	15°	17°	18°	19°	19°

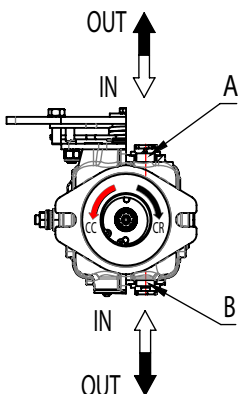

FLOW DIRECTION	PUMP		
	Lever position	OUT	IN
Pump rotation			
Clockwise CR	X	A	B
	Y	B	A
Counter-clockwise CC	X	B	A
	Y	A	B

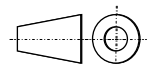

(continued)

DMS

CONTROL LEVER WITH RETURN TO ZERO FLOW POSITION

(torsion spring)

HYDRAULIC CIRCUIT

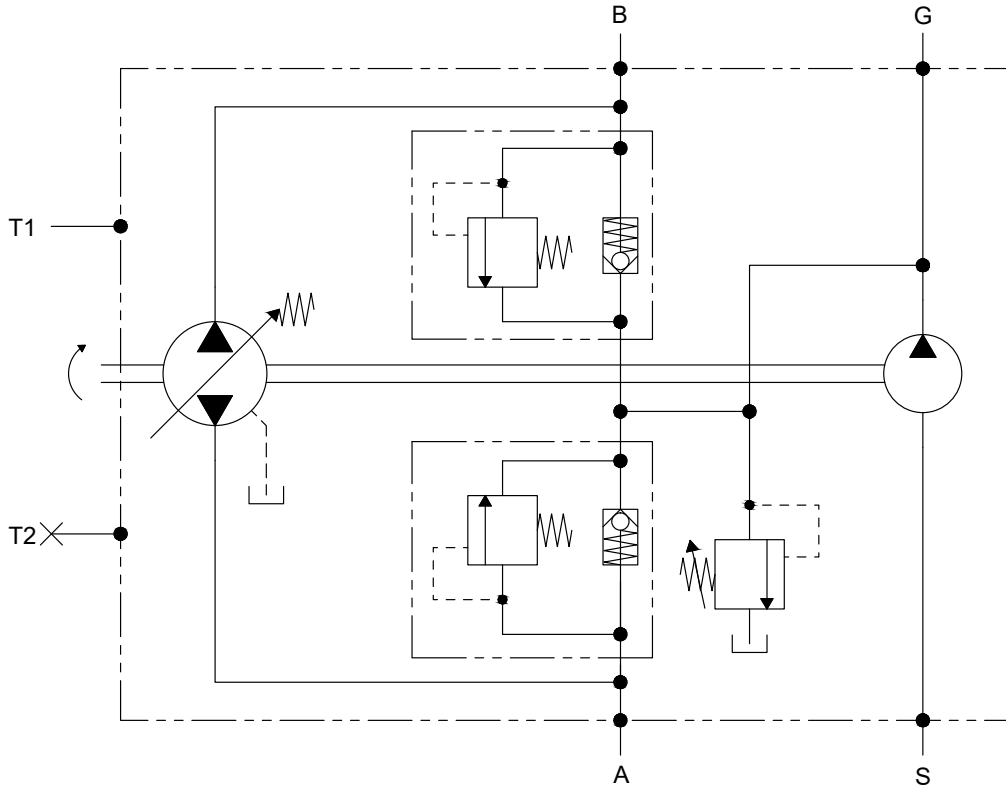

Standard spring diameter: **3,6 mm**
 Other available diameters: **3 - 3,3 - 4 - 5 mm**

Lever force - 10 MPa

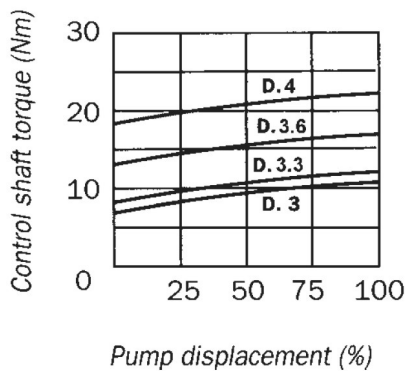

Lever force - 20 MPa

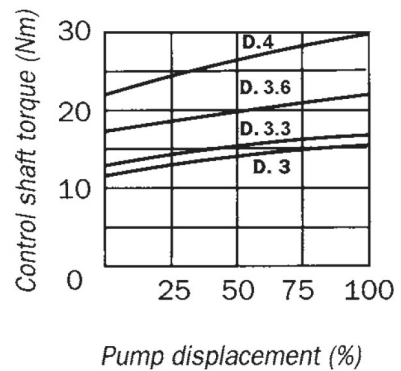

DMZ

CONTROL LEVER WITH RETURN TO ZERO FLOW POSITION

(compression spring)

The pump displacement variation is given by a clockwise or counter-clockwise movement of the lever.

Return to zero flow is obtained by a spring which is part of the leverism.

The lever shaft is directly linked to the swashplate.

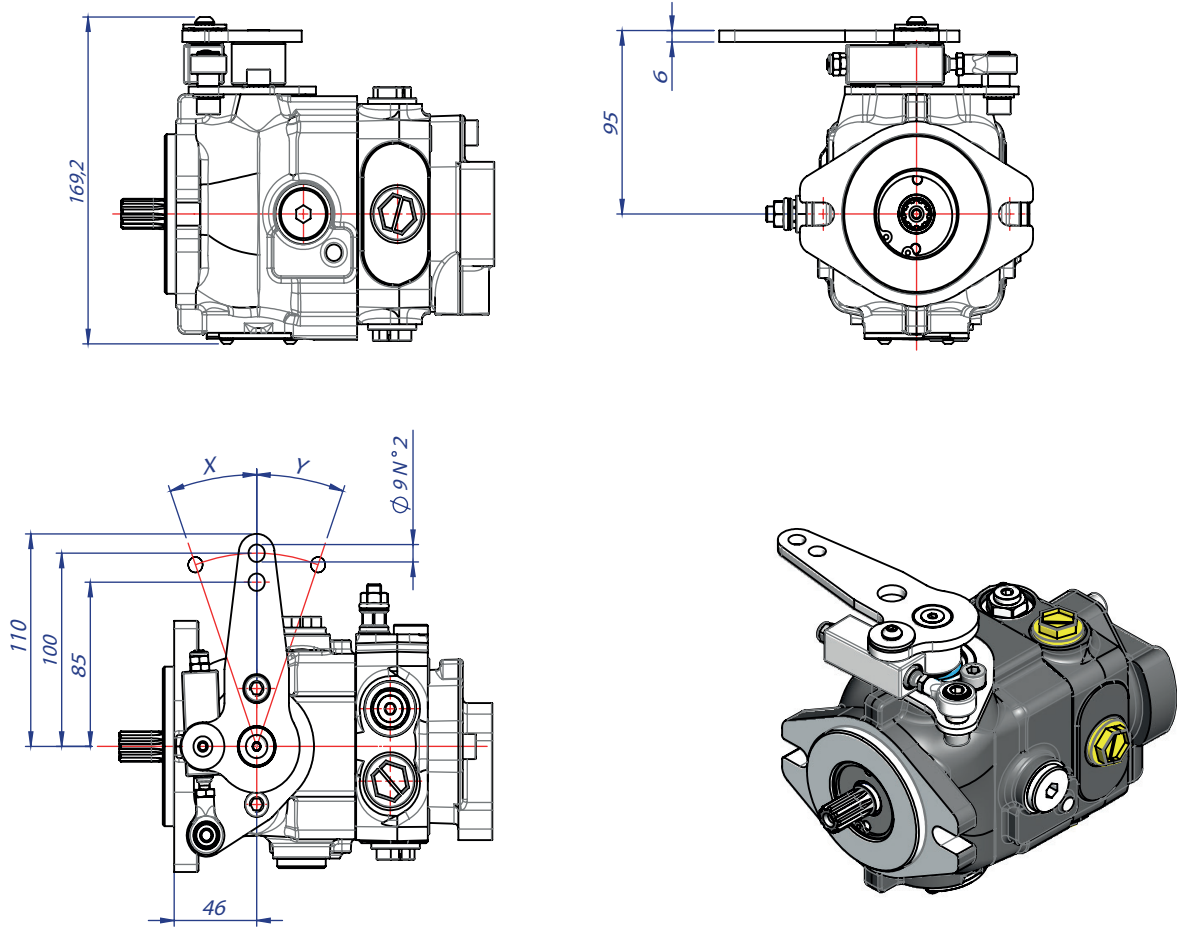

Lever Angle

Pump Model	6 / 7	8 / 7	9 / 7	11 / 7	12 / 7	13 / 7	15 / 9	17 / 9	18 / 9	19 / 9	21 / 9
Lever Angle (X - Y)	10°	12°	13°	15°	17°	18°	15°	17°	18°	19°	19°

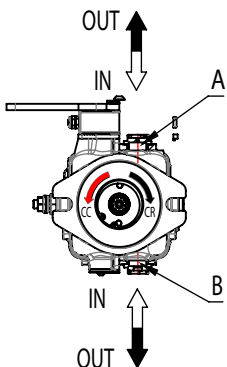

FLOW DIRECTION	PUMP		
	Lever position	OUT	IN
Pump rotation	X	A	B
	Y	B	A
Clockwise CR	X	B	A
	Y	A	B

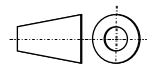

(continued)

DMZ

CONTROL LEVER WITH RETURN TO ZERO FLOW POSITION

(compression spring)

HYDRAULIC CIRCUIT

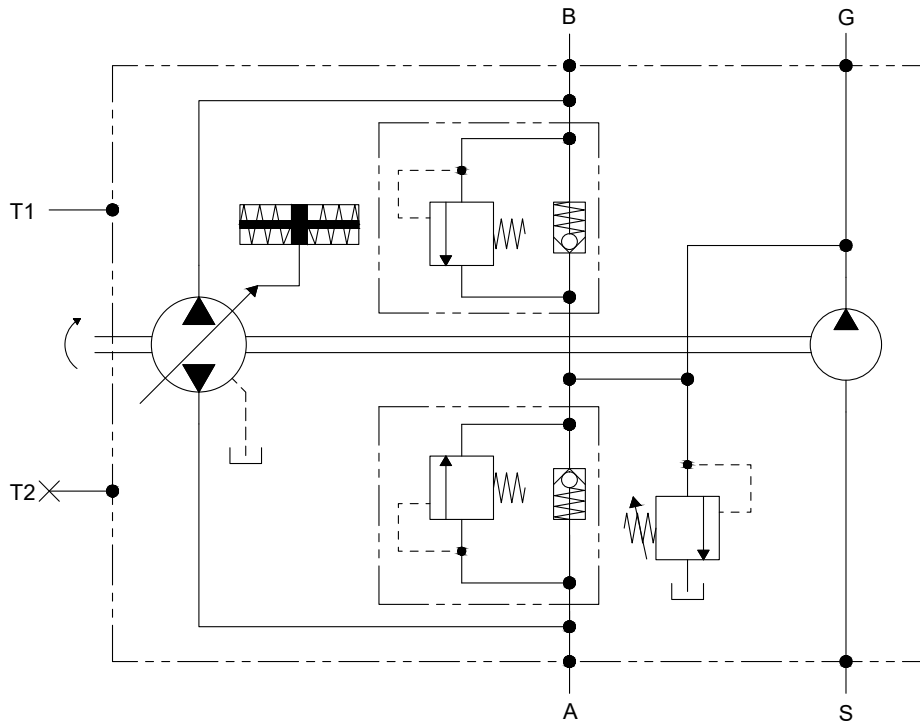

SHI

HYDRAULIC SERVO-CONTROL

The variation in pump displacement is obtained by adjusting the pressure on the P1-P2 servo control connections by means of a hydraulic proportional joystick (containing pressure reducing valves).

The oil supply for the joystick can be obtained by taking pressure from the boost pump (G port).

The servo control reacting time can be adju-

sted by inserting a restrictor on the joystick supply line (0,5 ÷ 1,2 mm).

The servo control operation curve in both control directions goes from 0,4 MPa to 1,8 MPa (tolerance ± 5%).

The adjustment curve of the hydraulic control system has to be wider (0,3 MPa ÷ 1,9 MPa). Suggested curves for HPV series Joysticks: CR062 (see HT/73/B/105/0919/E catalogue).

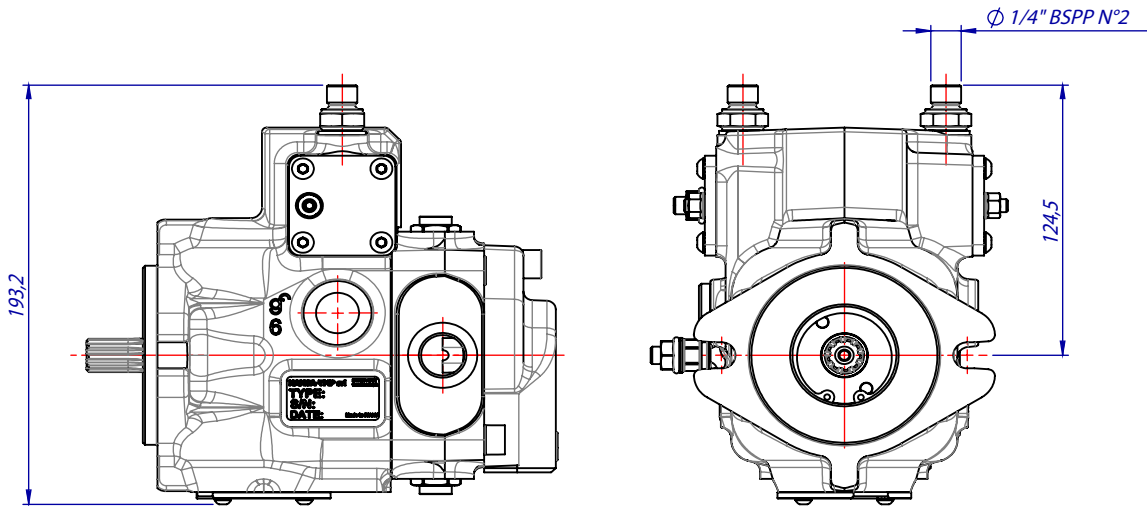

STANDARD CONNECTOR

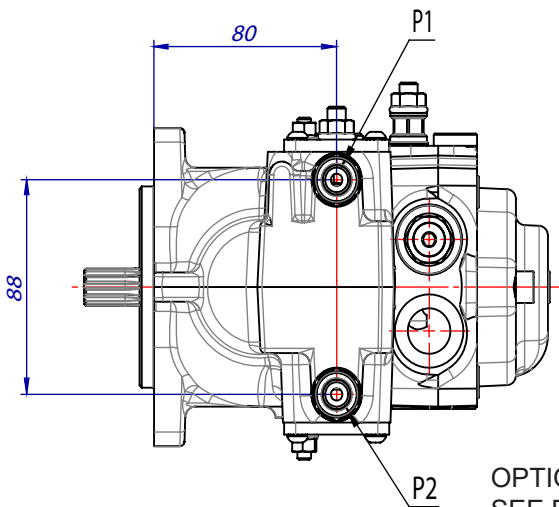
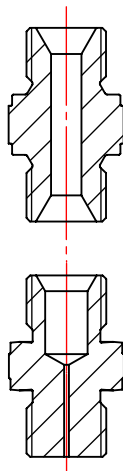

OPTIONAL RESTRICTOR ORIFICE
SEE POINT 18 ORDER CODE
FOR AVAILABILITY DIAMETERS

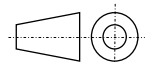
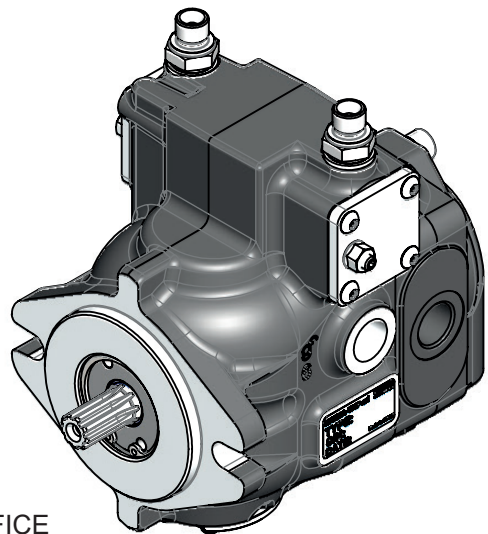

(continued)

SHI

HYDRAULIC SERVO-CONTROL

HYDRAULIC CIRCUIT

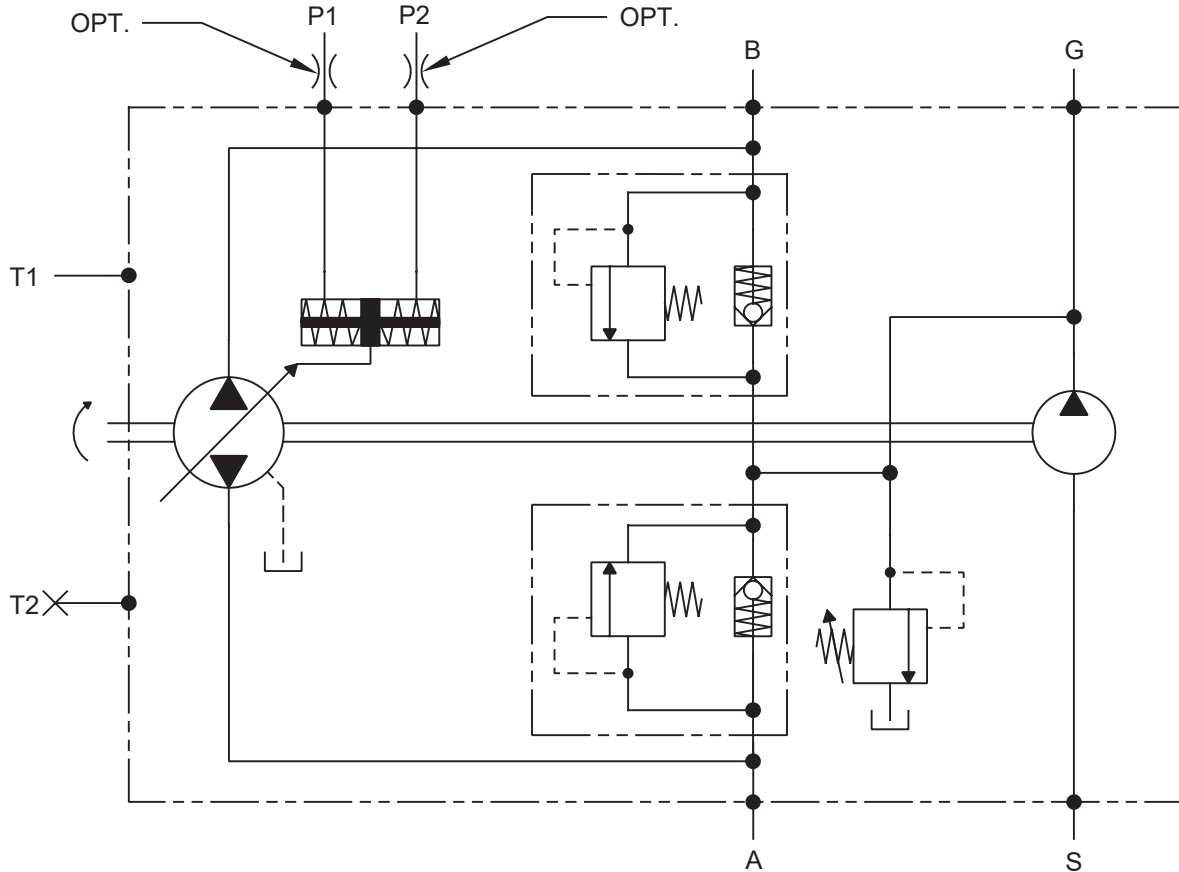

SERVO PRESSURE - DISPLACEMENT GRAPHIC

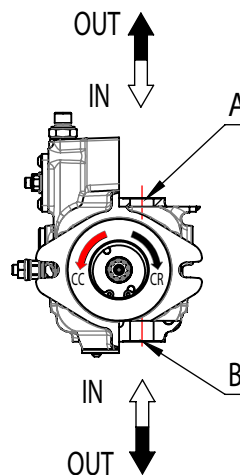
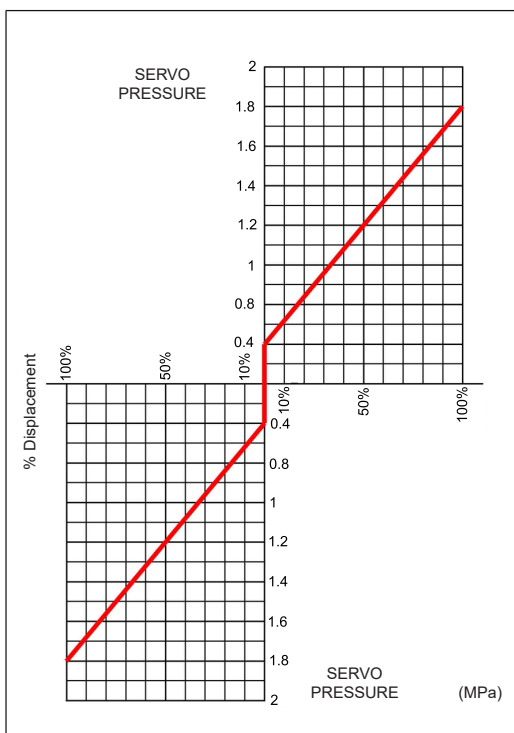

FLOW DIRECTION	PUMP		
	Port	OUT	IN
Pump rotation			
Clockwise CR	P ₁ P ₂	B A	A B
Counter-clockwise CC	P ₁ P ₂	A B	B A

SHIC

COMPACT HYDRAULIC SERVO-CONTROL

The variation in pump displacement is obtained by adjusting the pressure on the P1-P2 servo control connections by means of a hydraulic proportional joystick (containing pressure reducing valves).

The oil supply for the joystick can be obtained by taking pressure from the boost pump (G port). The servo control reacting time can be adjusted by inserting a restrictor on the

joystick supply line (0,5 ÷ 1,2 mm).

The servo control operation curve in both control directions goes from 0,4 MPa to 1,8 MPa (tolerance ± 5%).

The adjustment curve of the hydraulic control system has to be wider (0,3 MPa ÷ 1,9 MPa). Suggested curves for HPV series Joysticks: CR062 (see HT/73/B/105/0919/E catalogue).

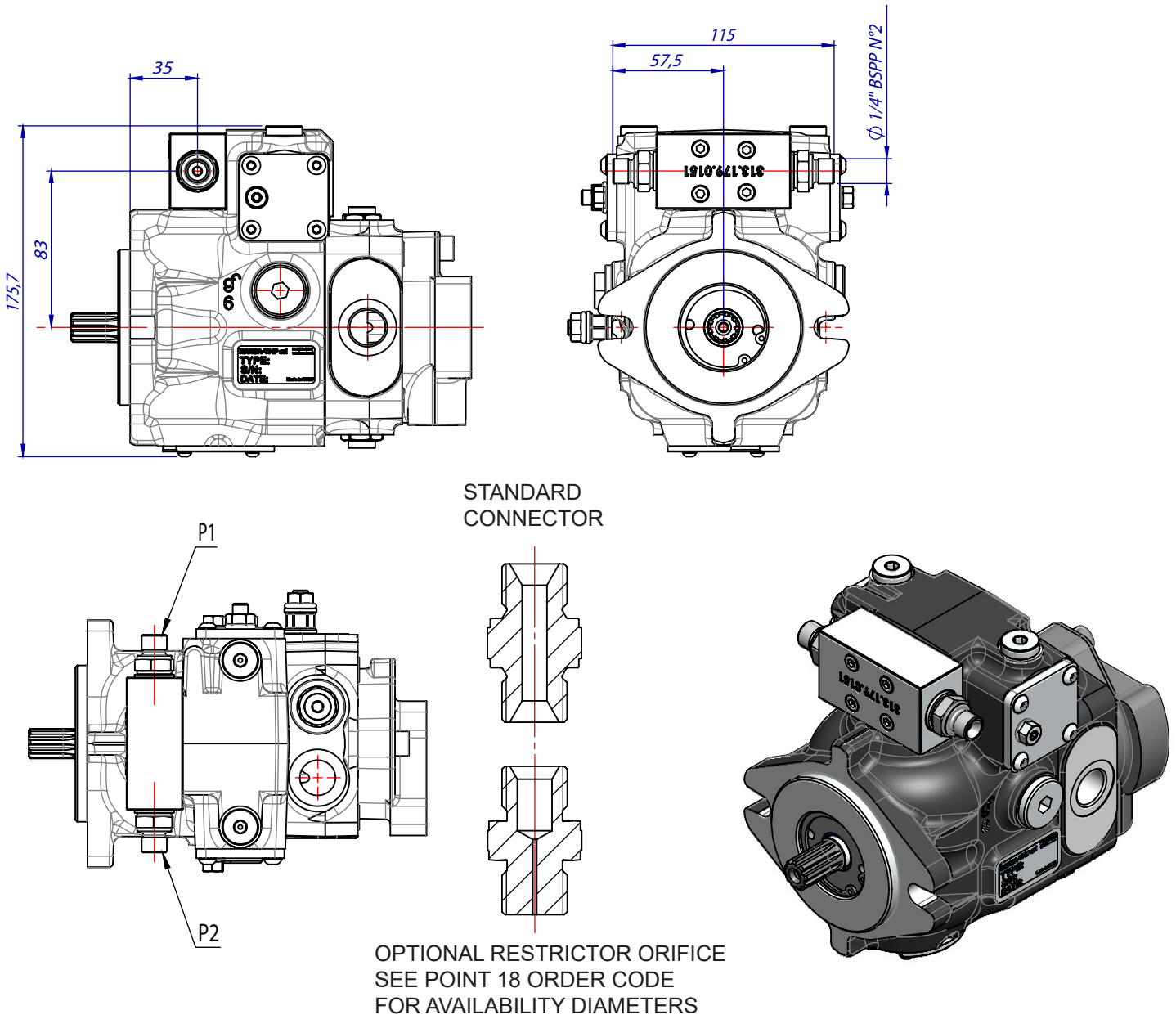

(continued)

SHIC

COMPACT HYDRAULIC SERVO-CONTROL

HYDRAULIC CIRCUIT

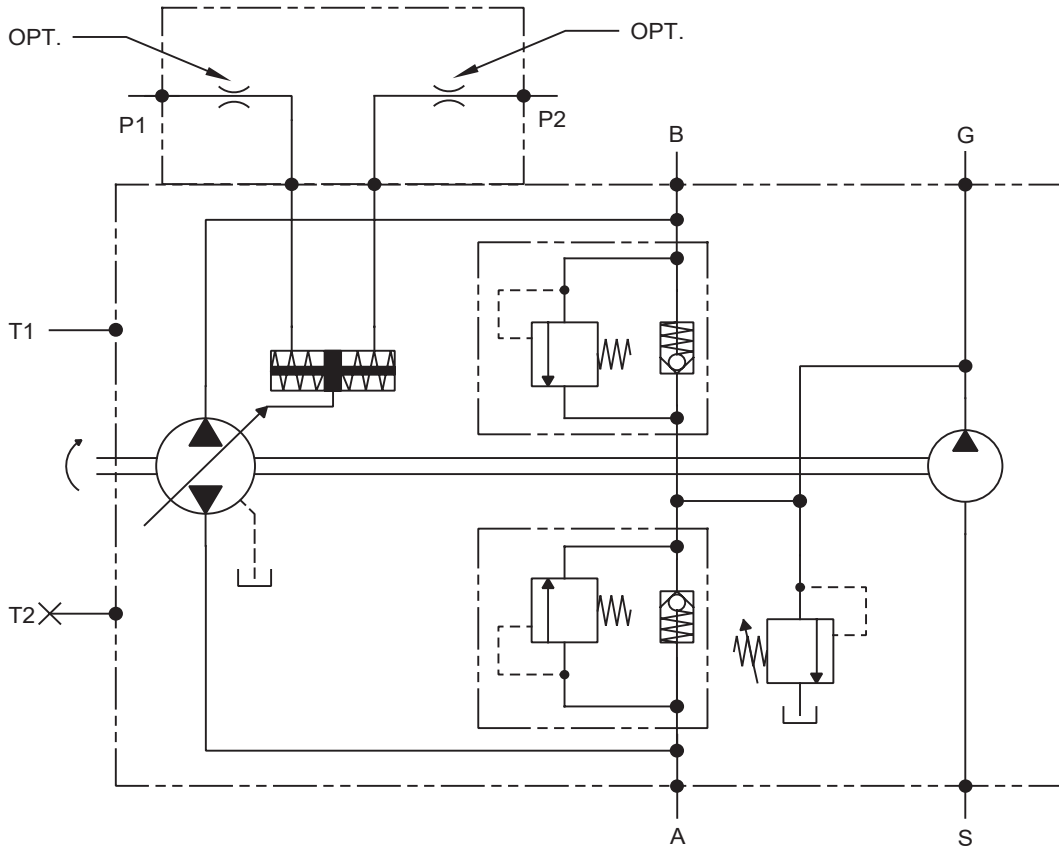

SERVO PRESSURE - DISPLACEMENT GRAPHIC

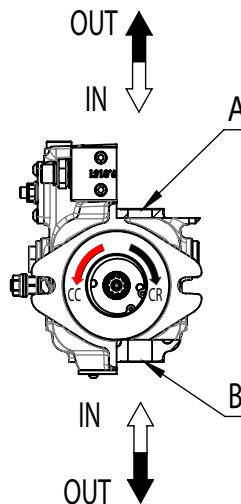
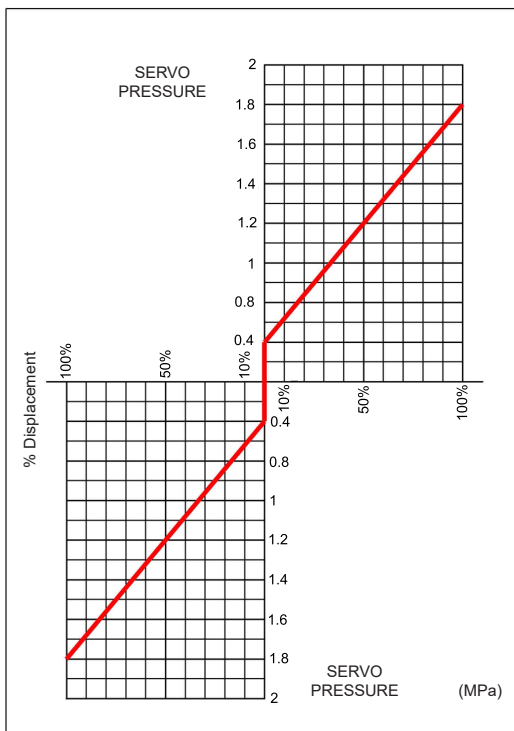

FLOW DIRECTION	PUMP		
	Port	OUT	IN
Pump rotation			
Clockwise CR	P ₁ P ₂	B A	A B
Counter-clockwise CC	P ₁ P ₂	A B	B A

SEI 1 (12V DC)
SEI 2 (24V DC)

ELECTRO-PROPORTIONAL SERVO-CONTROL

(with AMP Junior Timer connector)

The pump displacement variation is obtained by an electric signal, which varies approx.:

- from 315 to 630 mA (24V DC voltage)
- from 630 to 1260 mA (12V DC voltage)

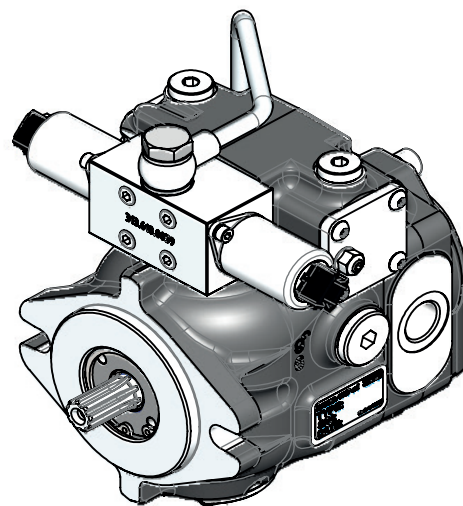
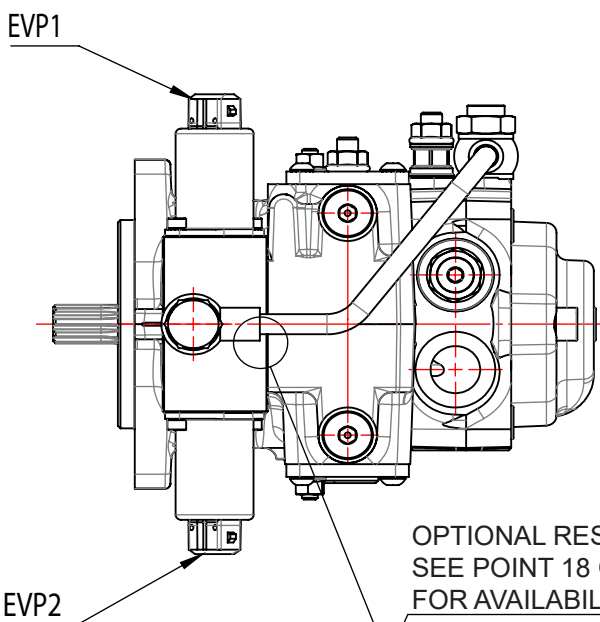
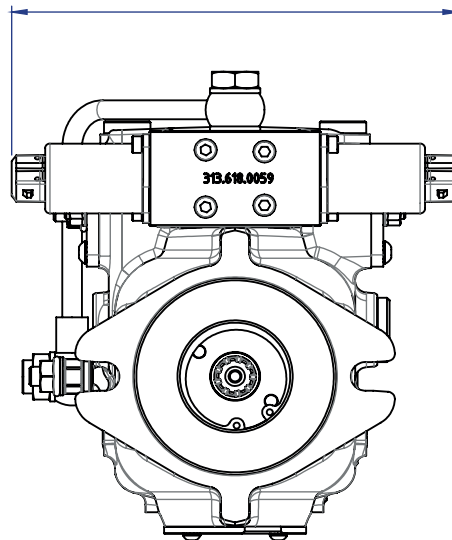
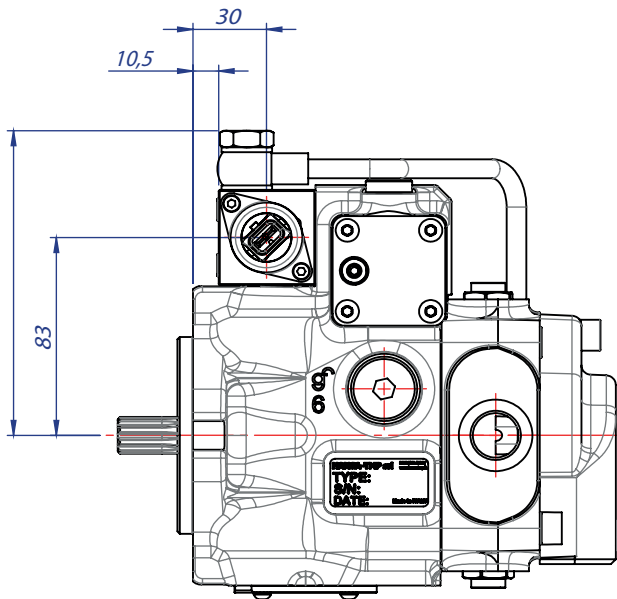

OPTIONAL RESTRICTOR ORIFICE
SEE POINT 18 ORDER CODE
FOR AVAILABILITY DIAMETERS

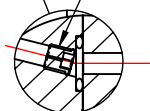

(continua)

SEI 1 (12V DC)

SEI 2 (24V DC)

ELECTRO-PROPORTIONAL SERVO-CONTROL

(with AMP Junior Timer connector)

HYDRAULIC CIRCUIT

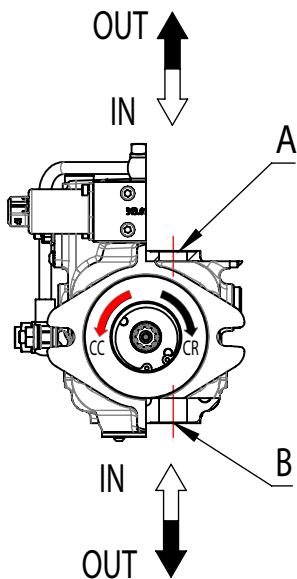
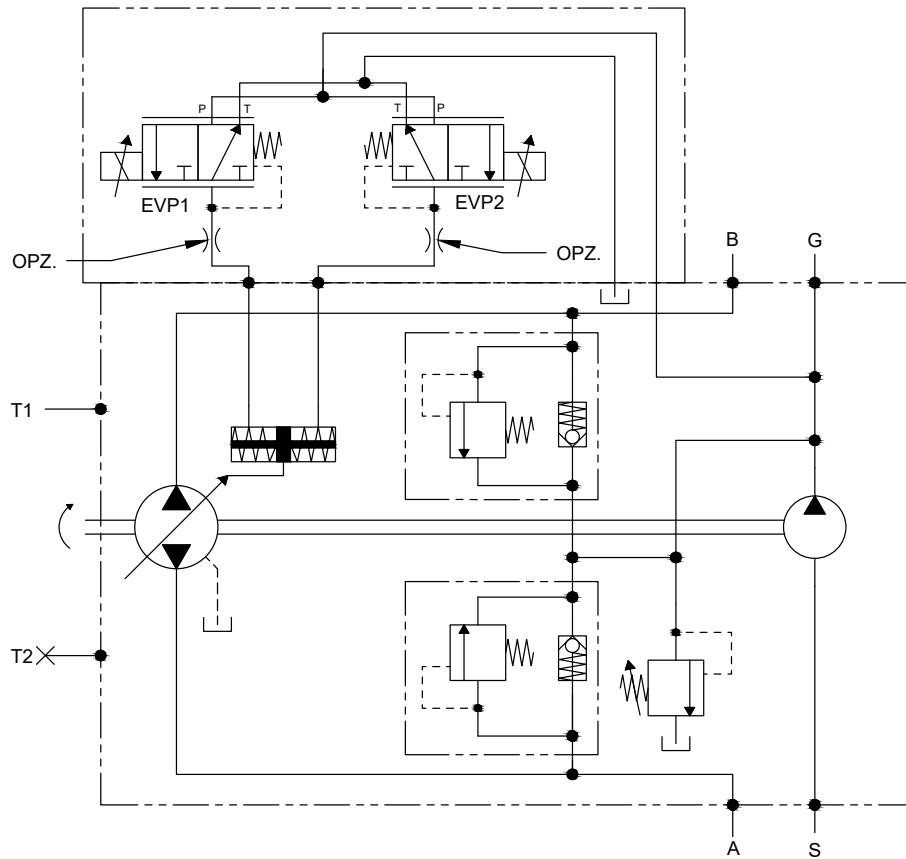

FLOW DIRECTION	PUMP		
	Port	OUT	IN
Clockwise CR	EVP1	B	A
	EVP2	A	B
Counter-clockwise CC	EVP1	A	B
	EVP2	B	A

(continua)

SEI 1 (12V DC)

SEI 2 (24V DC)

ELECTRO-PROPORTIONAL SERVO-CONTROL

(with AMP Junior Timer connector)

CURRENT-DISPLACEMENT GRAPHIC

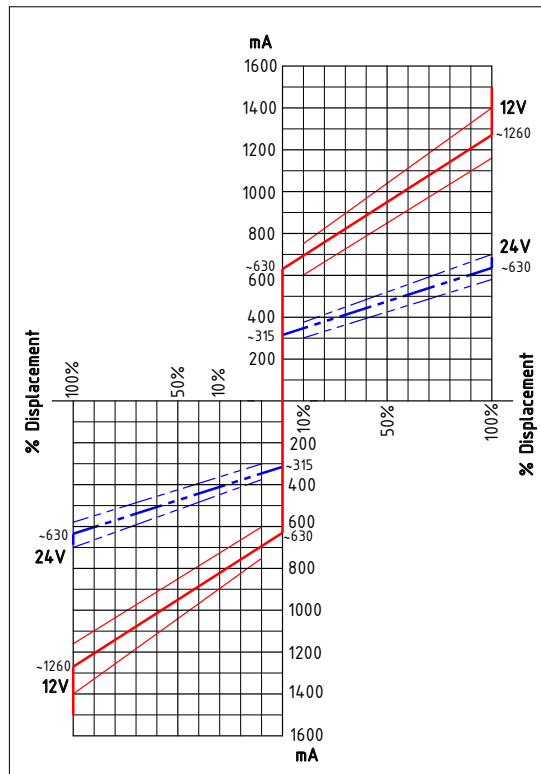

ELECTRICAL FEATURES		
Voltage	12 V	24 V
Electric current max.	1500 mA	750 mA
Load resistance	4,72 Ω ± 5%	20,8 Ω ± 5%
Type of control	Current control	
	PWM 100 Hz indicated	
Type of connection	AMP Junior Timer	
Protection class	Until IP6K6 / IPX9K	

HYDRAULIC FEATURES	
Max. pressure (P, T)	pP= 5 MPa, pT= 3 MPa
Hysteresis (w/PWM)	<0,07 MPa (pA=2,0)
	<0,1 MPa (pA=2,5)
	<0,15 MPa (pA=3,5)
Filtration ratio	125 µm
Oil contamination level	Min. filtration ratio: 20/18/15
	According ISO 4406
	Hydraulic oil DIN 51524
Min./max. oil temperature	from -40 to +105°C

SEI 1.D (12V DC)
SEI 2.D (24V DC)

ELECTRIC SERVO-CONTROL

(with Deutsch connector)

The pump displacement variation is obtained by an electric signal, which varies approximately:

- from 315 to 630 mA (24V DC voltage)
- from 630 to 1260 mA (12V DC voltage)

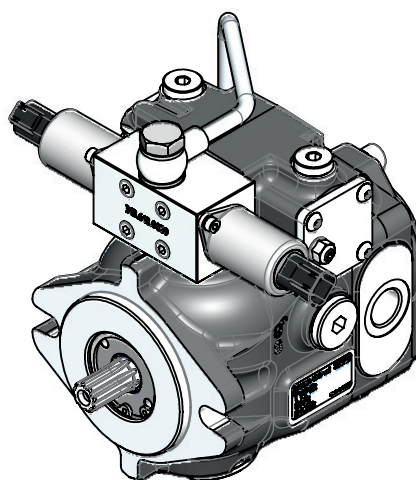
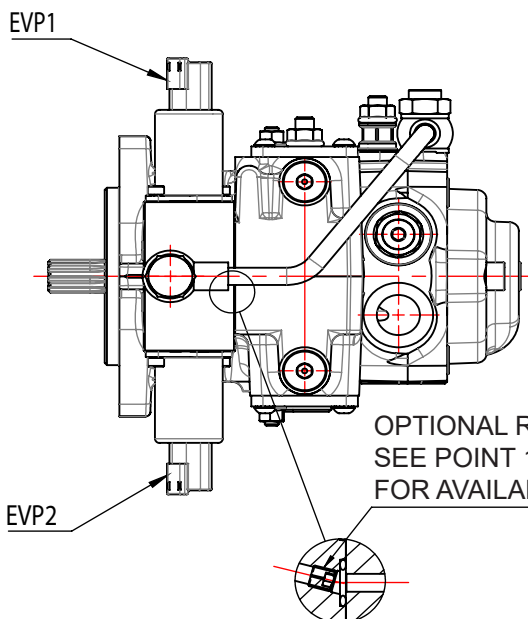
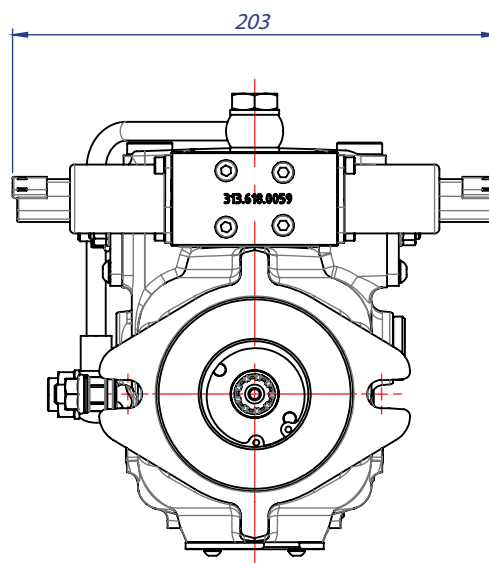
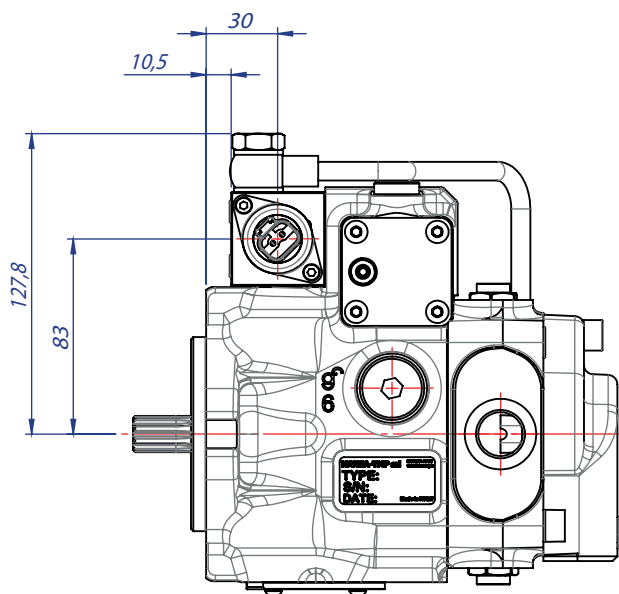

SEI 1.D (12V DC)

SEI 2.D (24V DC)

ELECTRIC SERVO-CONTROL

(with Deutsch connector)

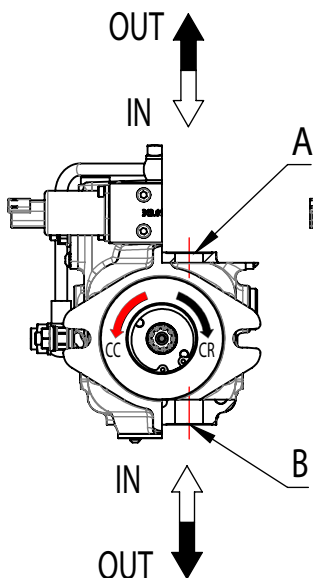
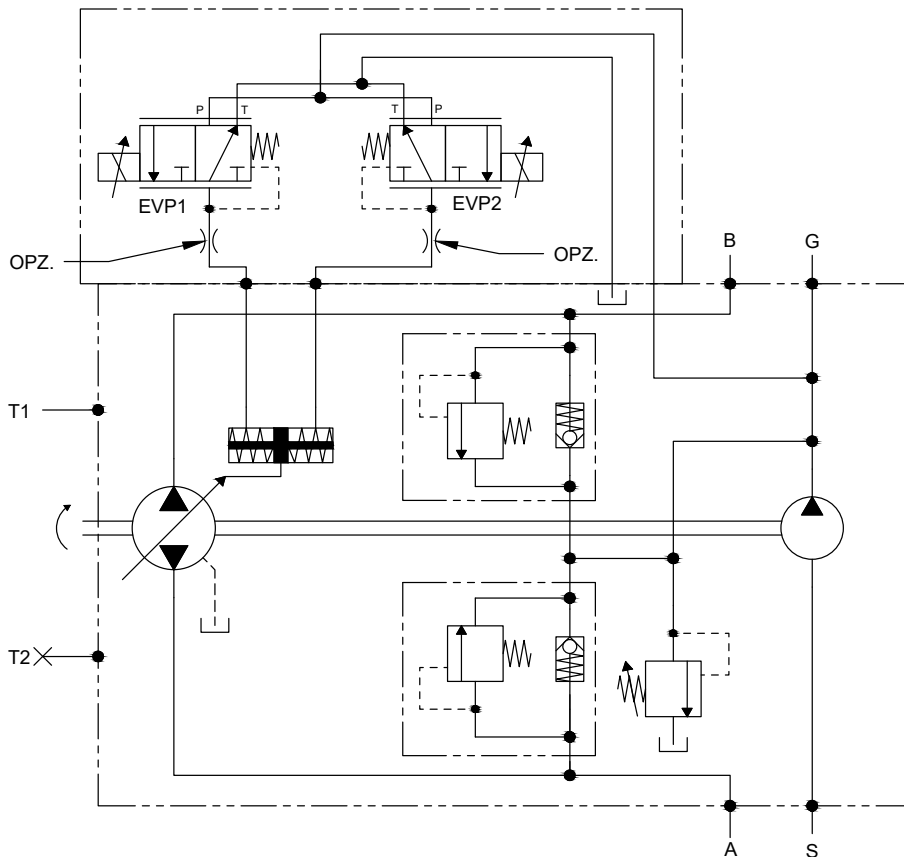

FLOW DIRECTION	PUMP		
	Port	OUT	IN
Clockwise CR	EVP1	B	A
	EVP2	A	B
Counter-clockwise CC	EVP1	A	B
	EVP2	B	A

SEI 1.D (12V DC)

SEI 2.D (24V DC)

ELECTRIC SERVO-CONTROL

(with Deutsch connector)

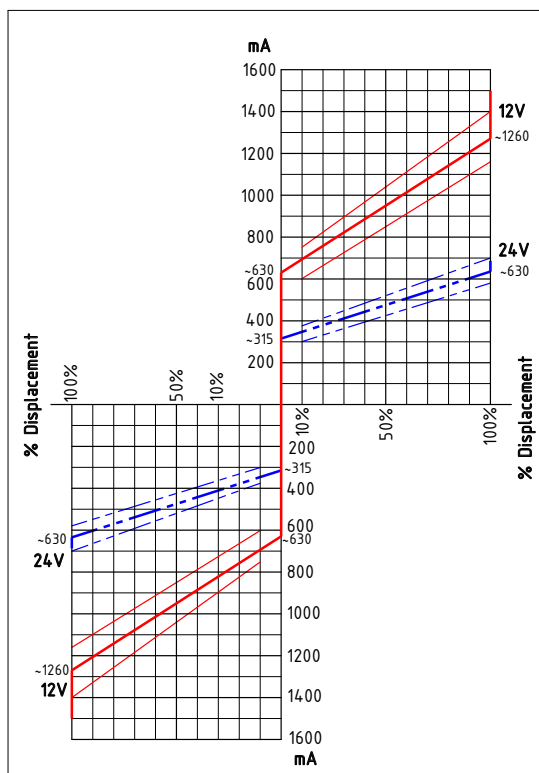
CURRENT-DISPLACEMENT GRAPHIC

ELECTRICAL FEATURES		
Voltage	12 V	24 V
Electric current max.	1500 mA	750 mA
Load resistance	4,72 $\Omega \pm 5\%$	20,8 $\Omega \pm 5\%$
Type of control	Current control	
	PWM 100 Hz indicated	
Type of connection	Deutsch	
Protection class	Until IP6K6 / IPX9K	

HYDRAULIC FEATURES	
Max. pressure (P, T)	pP= 5 MPa, pT= 3 MPa
Hysteresis (w/PWM)	<0,07 MPa (pA=2,0)
	<0,1 MPa (pA=2,5)
	<0,15 MPa (pA=3,5)
Filtration ratio	125 μm
Oil contamination level	Min. filtration ratio: 20/18/15
	According ISO 4406
	Hydraulic oil DIN 51524
Min./max. oil temperature	from -40 to +105°C

CONTROL DEVICE POSITION

(Primary and secondary pump)

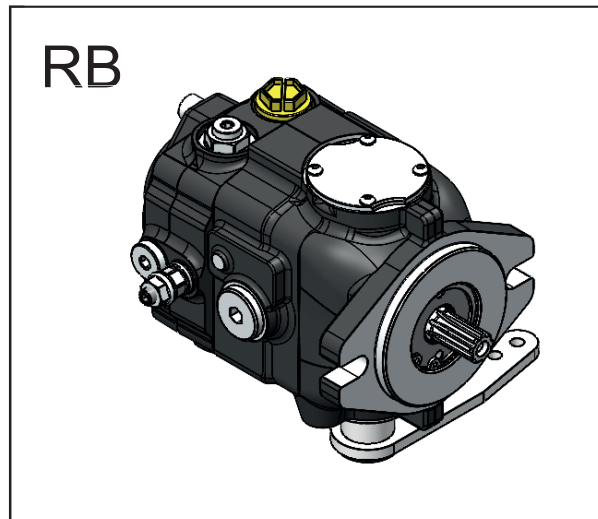
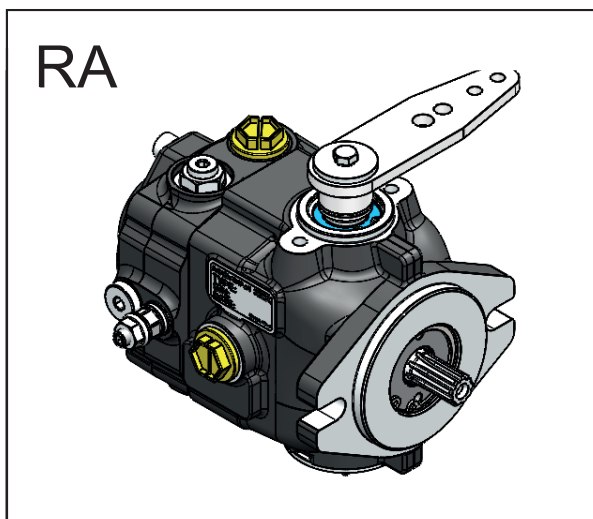
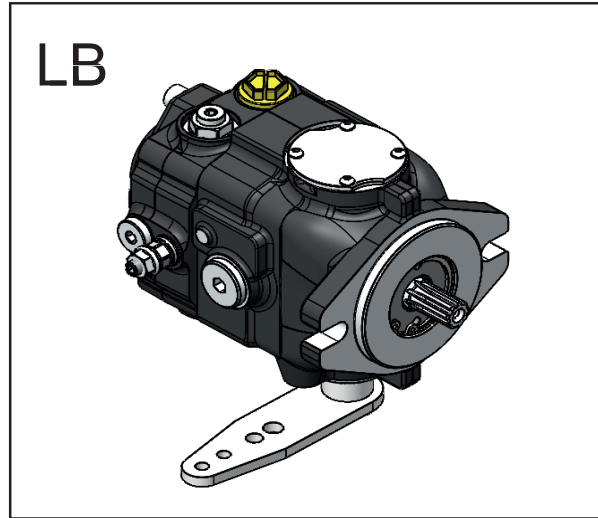
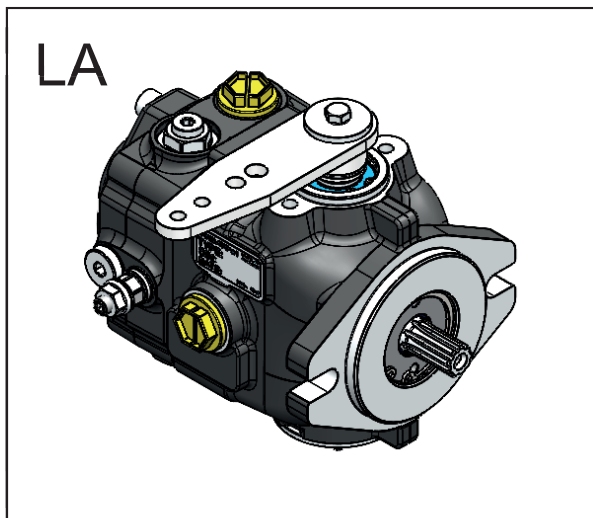
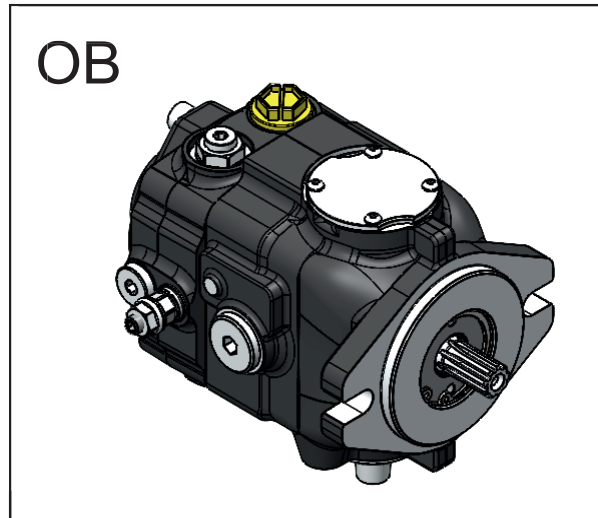
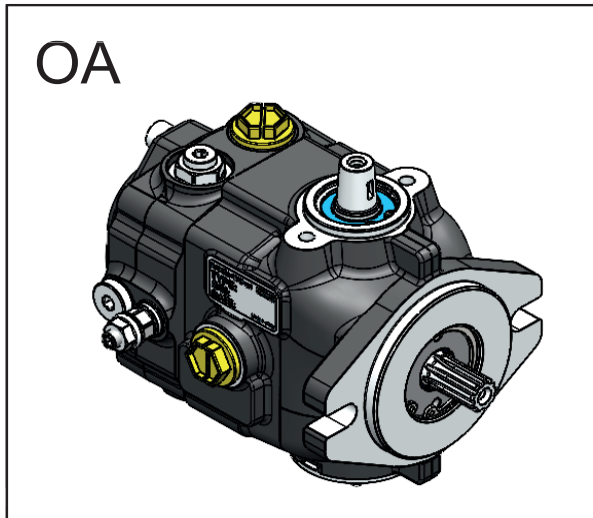

CONTROL DEVICE POSITION

(Primary and secondary pump)

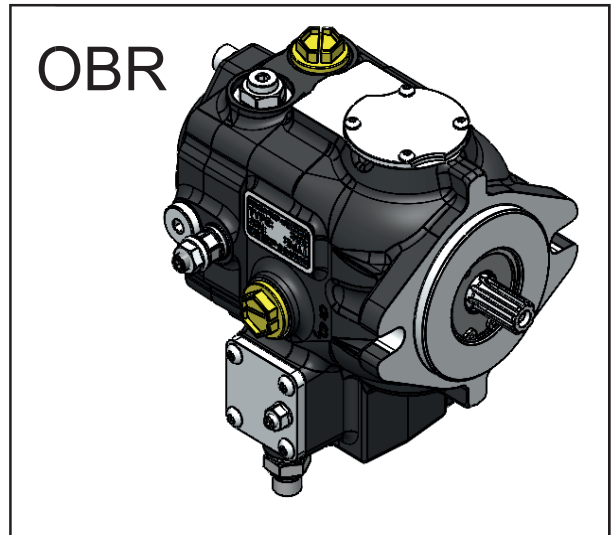
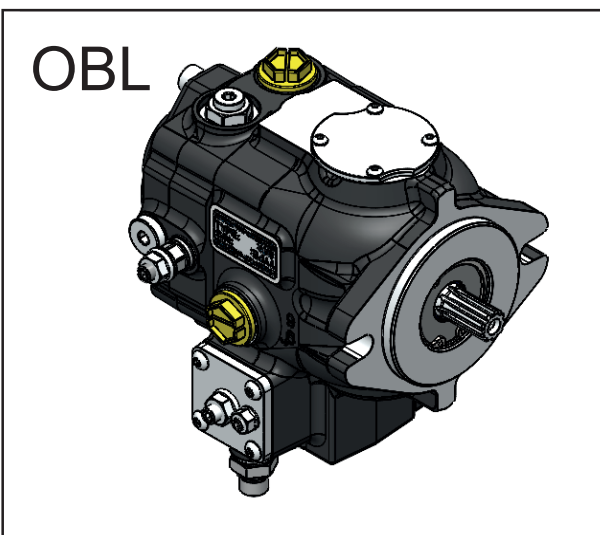
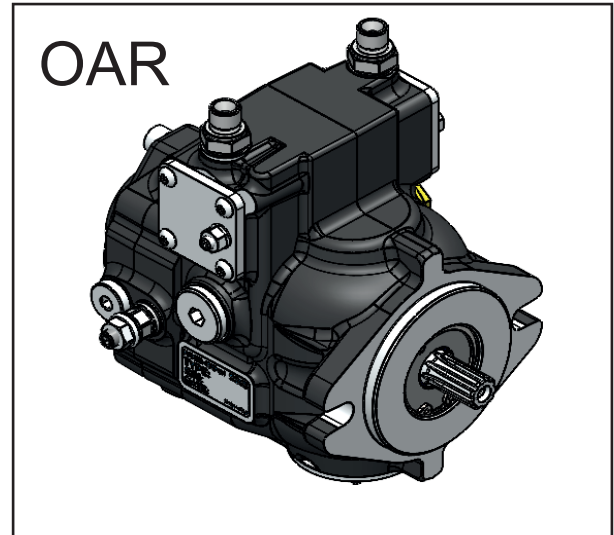
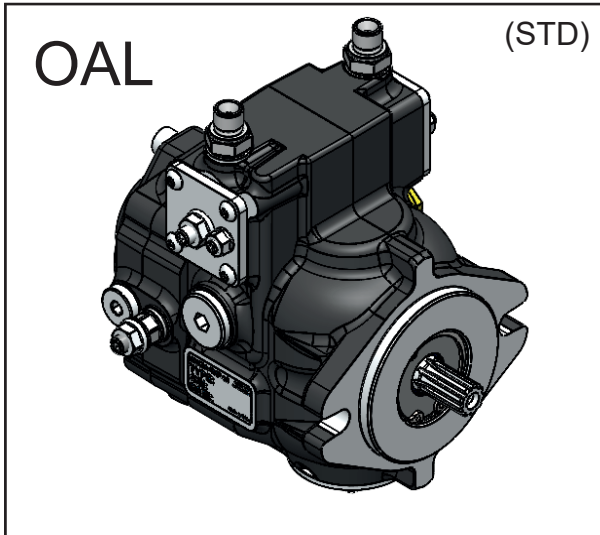

GEAR PUMPS CONNECTION

F

**OPTIONAL
GROUP 1**

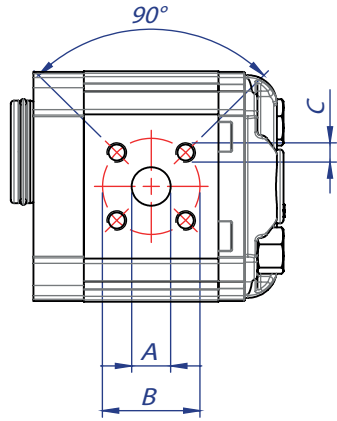

PUMP CONNECTION SIZE					
SUCTION IN			OUTLET OUT		
A	B	C	A	B	C
12 mm	30 mm	M6	12 mm	30 mm	M6

G

**STANDARD
GROUP 1**

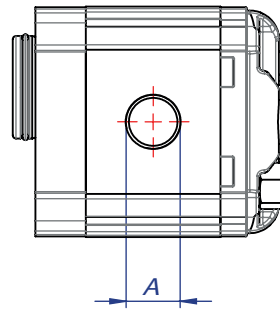

PUMP CONNECTION SIZE	
SUCTION IN	OUTLET OUT
A	A
3/8" BSPP	3/8" BSPP

**STANDARD
GROUP 2**

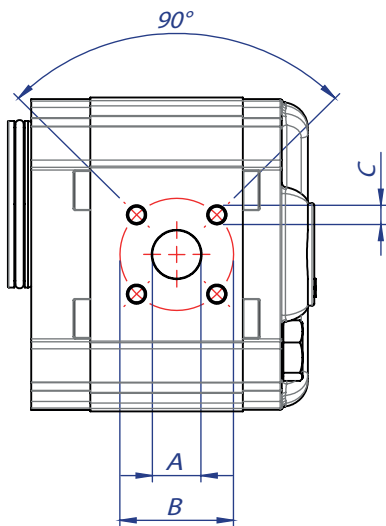

PUMP CONNECTION SIZE					
SUCTION IN			OUTLET OUT		
A	B	C	A	B	C
20 mm	40 mm	M6	15 mm	35 mm	M6

**OPTIONAL
GROUP 2**

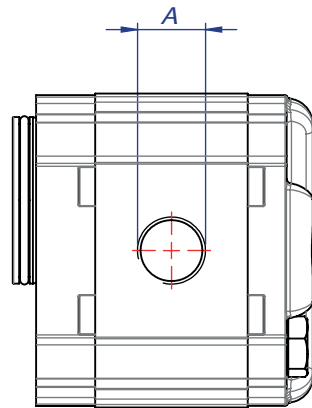

PUMP CONNECTION SIZE		
DISPLACEMENT	SUCTION IN	OUTLET OUT
cm³/n	A	A
4	G 1/2"	G 1/2"
6		
8		
11	G 3/4"	
14		
16		
19		
22		
26		
31		

REAR PUMP MOUNTING FLANGES

(Dimensions valid for all versions)

C

CLOSED (WITHOUT CONNECTION FOR REAR PUMP) - STANDARD VERSION

CR
clockwise rotation
(right)

CC
counter-clockwise rotation
(left)

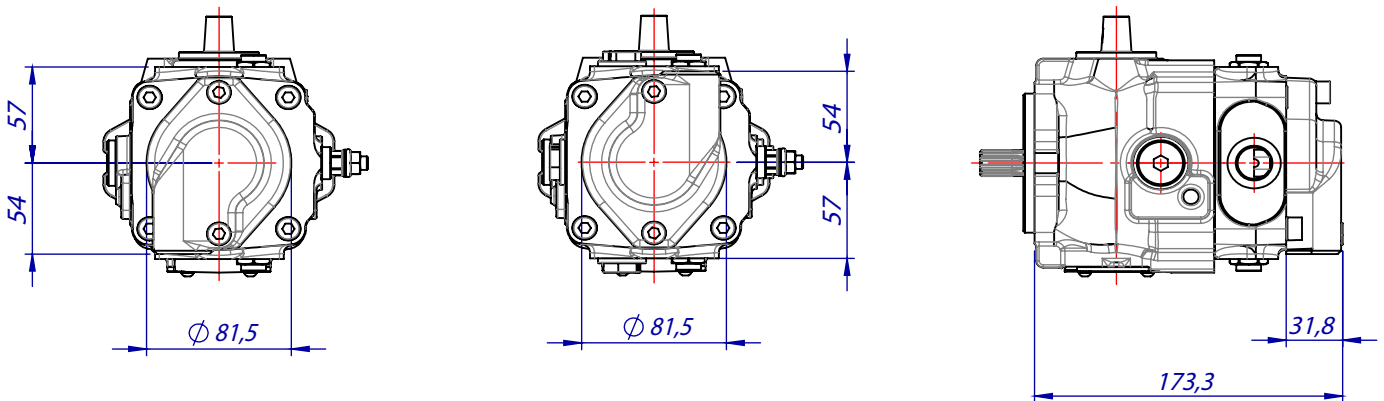

B1

GERMAN STANDARD (WITHOUT BOOST PUMP) COMPACT VERSION

Max. torque = 70 Nm

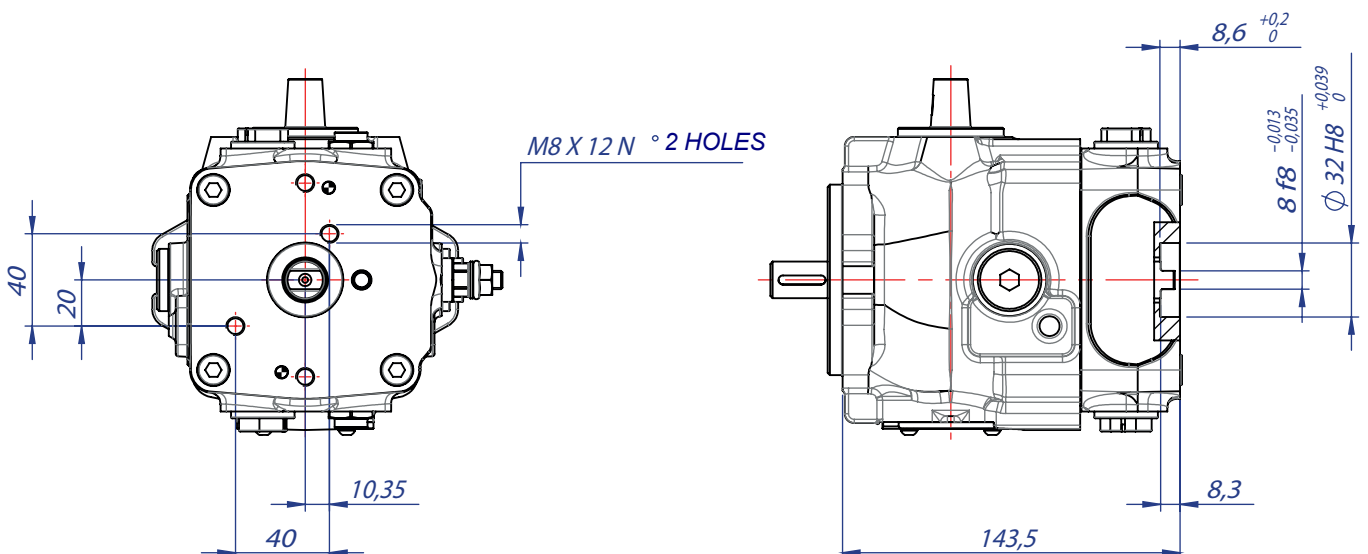

REAR PUMP MOUNTING FLANGES

(Dimensions valid for all versions)

B1

GERMAN STANDARD

Max. torque = 70 Nm

CR
clockwise rotation
(right)

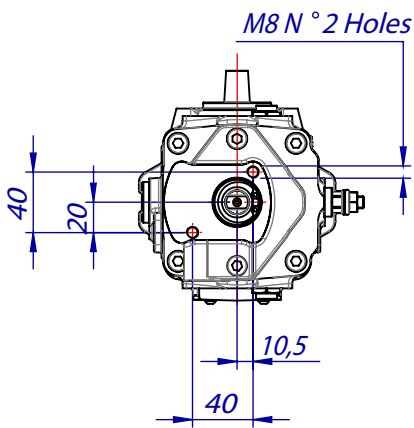

CC
counter-clockwise rotation
(left)

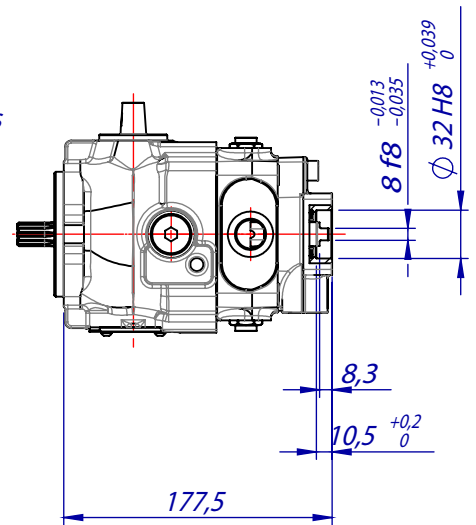
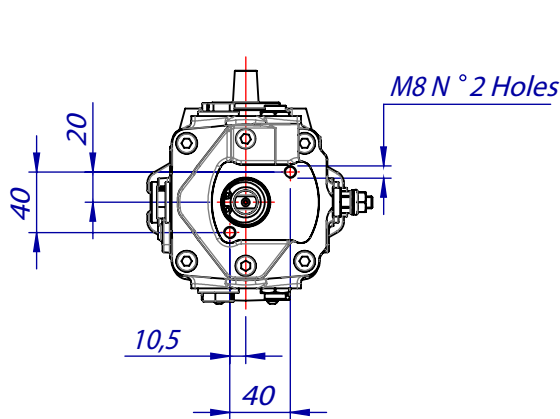

B2

GERMAN STANDARD

Max. torque = 70 Nm

CR
clockwise rotation
(right)

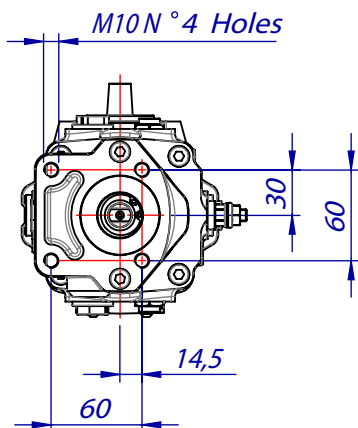

CC
counter-clockwise rotation
(left)

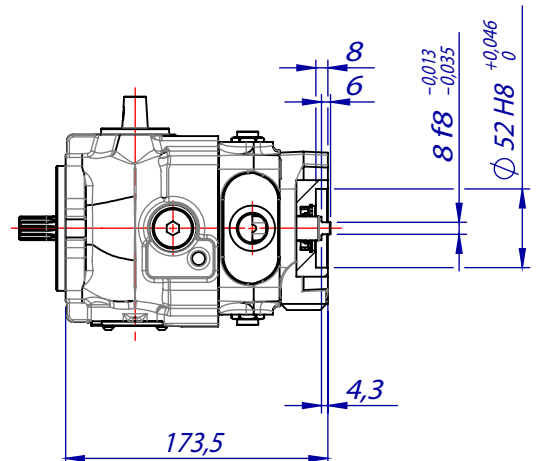
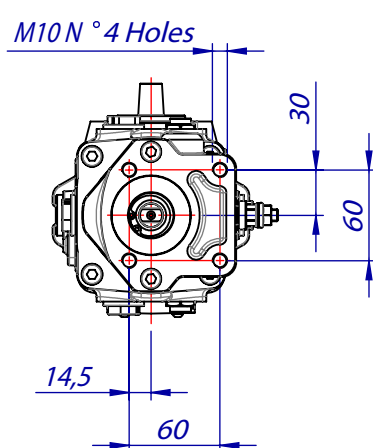

REAR PUMP MOUNTING FLANGES

(Dimensions valid for all versions)

B2

GERMAN STANDARD (WITHOUT BOOST PUMP) COMPACT VERSION

Max. torque = 70 Nm

CR
clockwise rotation
(right)

CC
counter-clockwise rotation
(left)

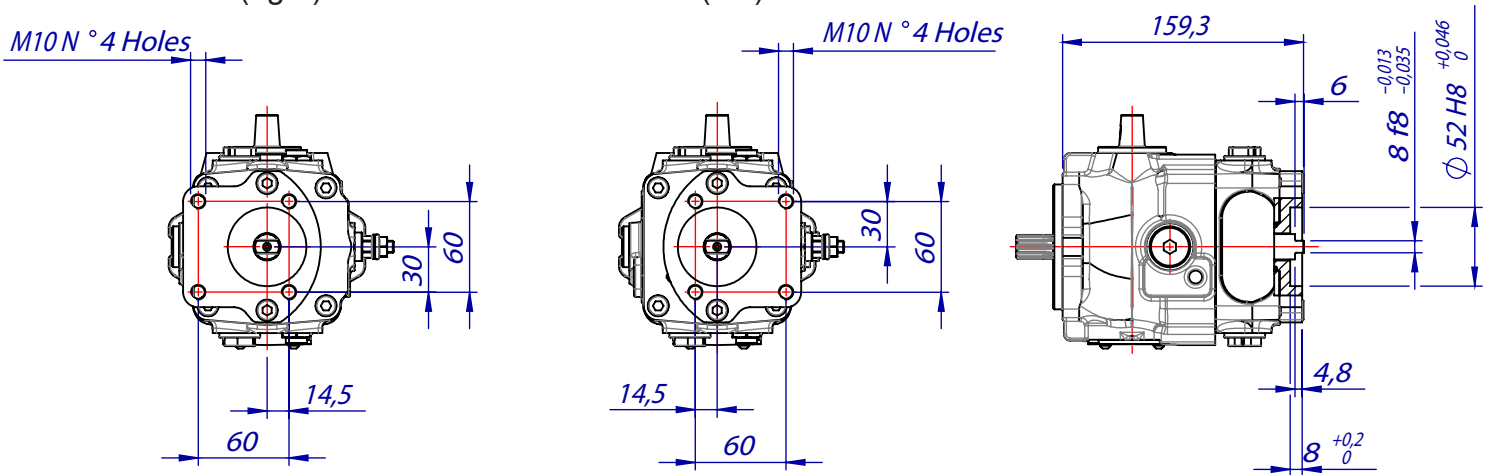

SA

SAE-A - 2 HOLES FLANGE

Max. torque = 120 Nm

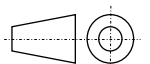
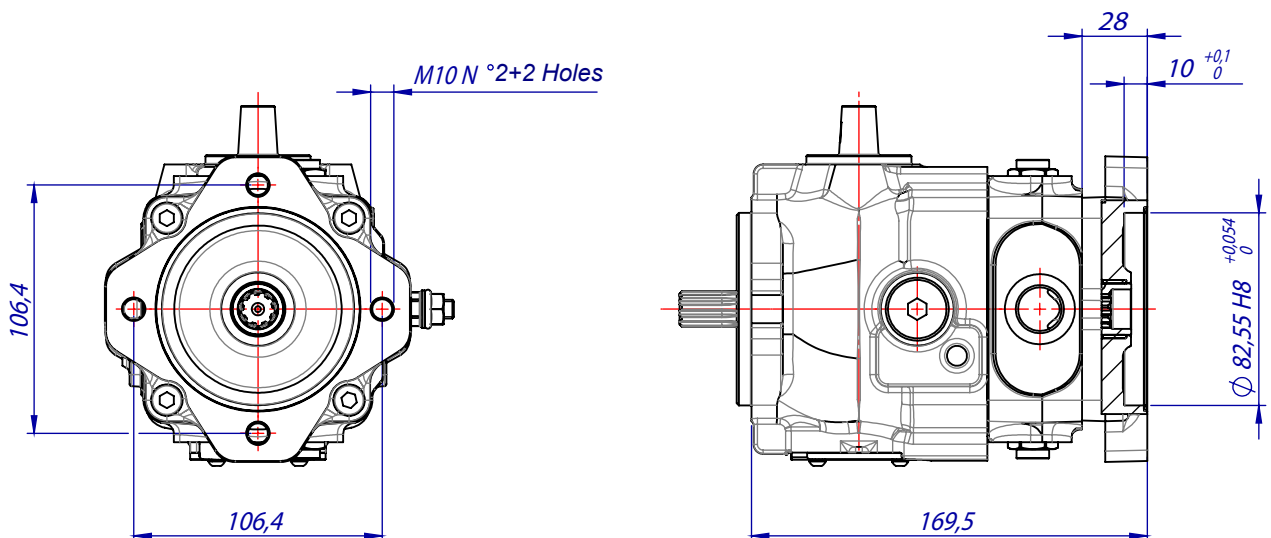

REAR PUMP MOUNTING FLANGES

(Dimensions valid for all versions)

SA-C

SAE-A - 2+2 HOLES FLANGE + CLOSED COVER

Max. torque = 120 Nm

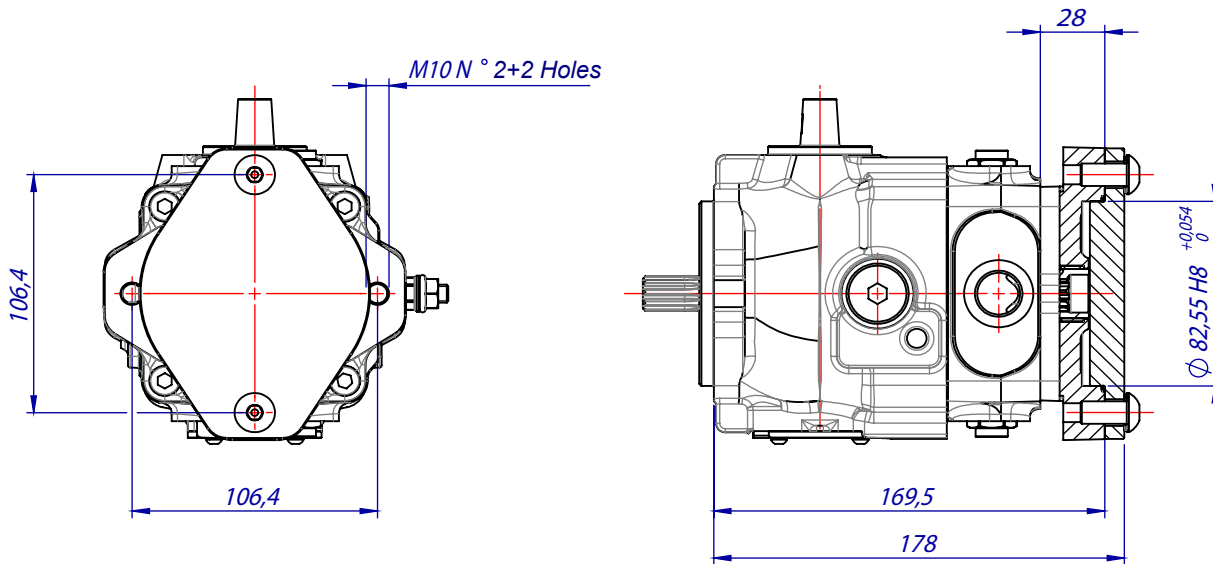

OPTIONAL LB

LEVER BY-PASS

Manual valve to connect the A and B ports together to allow the free-wheeling of the hydraulic motor.

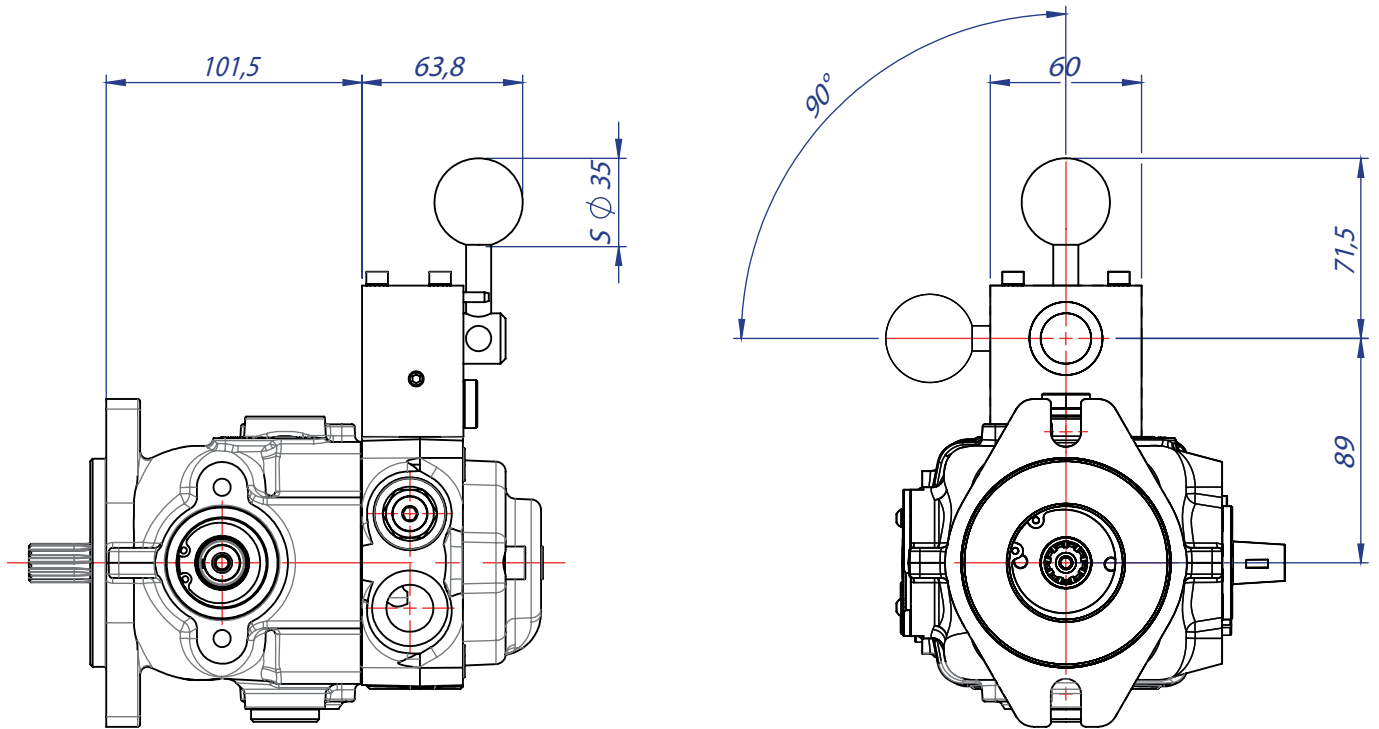

HYDRAULIC CIRCUIT

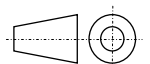
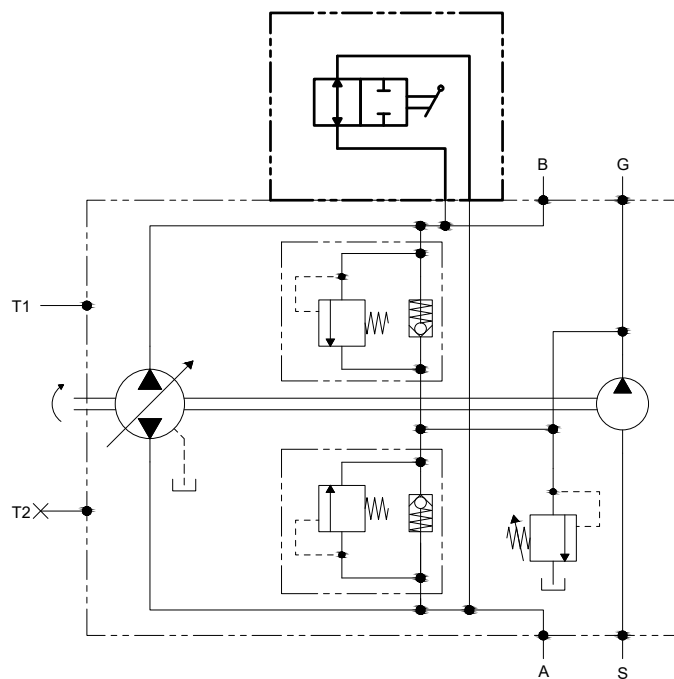

OPTIONAL VS FLUSHING VALVE

Subtracting warm oil from the closed circuit, the flushing valve allows the flow of cool fluid from the boost system. Oil flow for cooling from 1.1 l/min (with 1 MPa pressure) up to 1.6 l/min (with 2 MPa pressure).

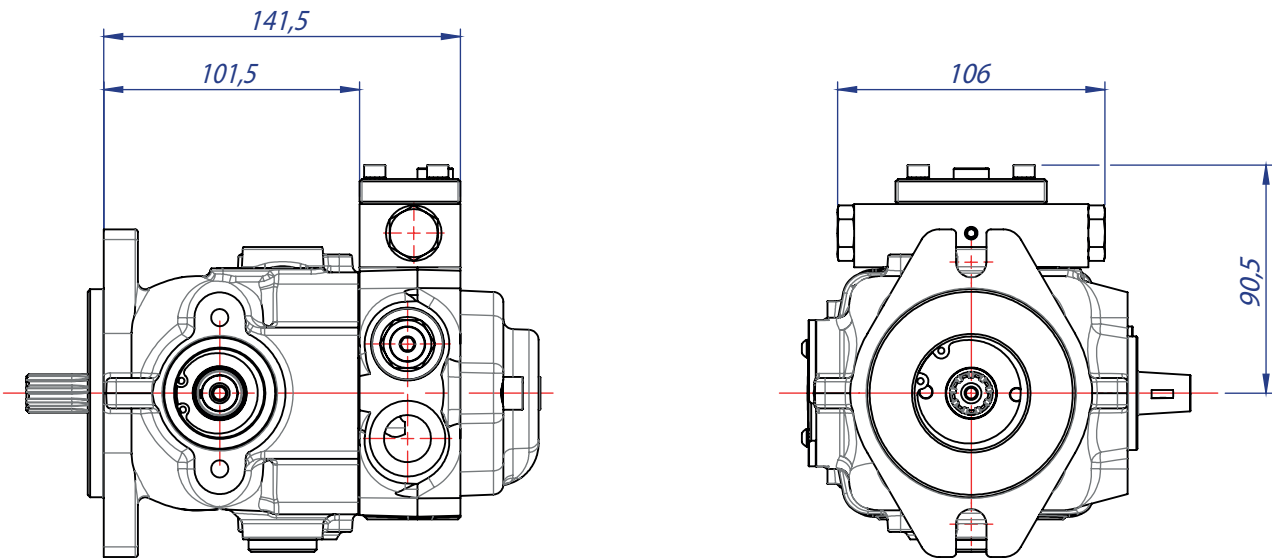

HYDRAULIC CIRCUIT

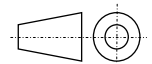
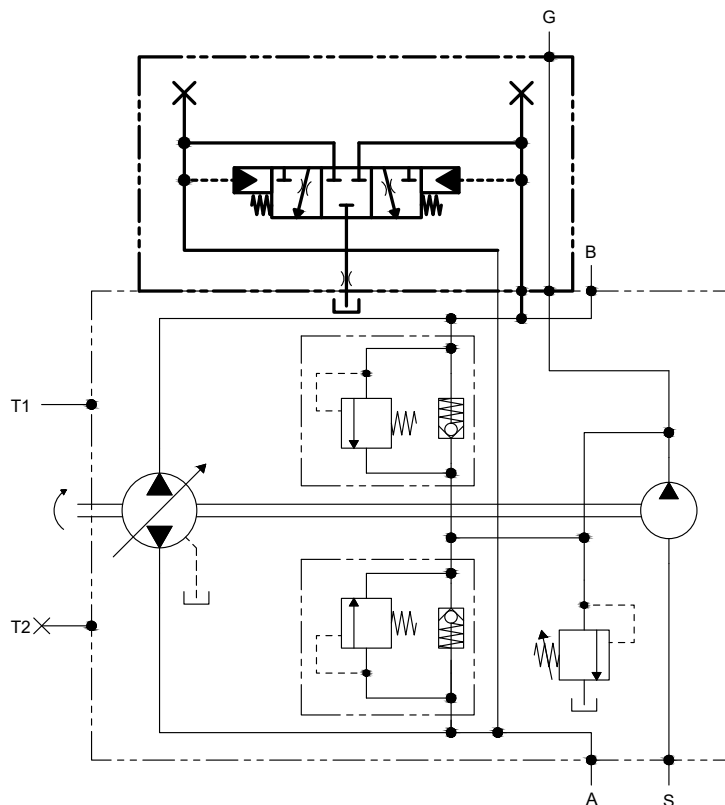

OPTIONAL VSLB

FLUSHING VALVE + LEVER BY-PASS

The manual valve connects the A and B ports together to allow the free-wheeling of the hydraulic motor.
The flushing valve, subtracting warm oil from the closed circuit, allows the flow of cool fluid

from the boost system.
Oil flow for cooling from 1.1 l/min (with 1 MPa pressure) up to 1.6 l/min (with 2 MPa pressure).

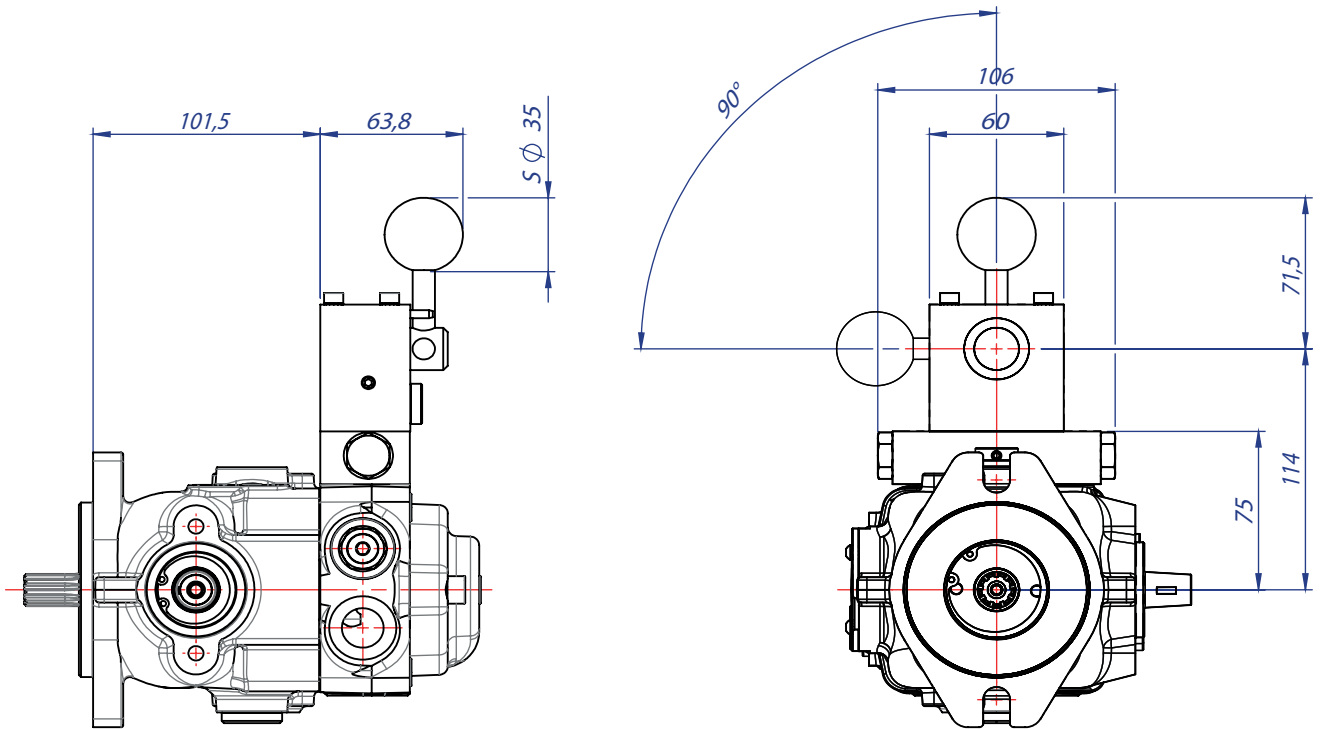

HYDRAULIC CIRCUIT

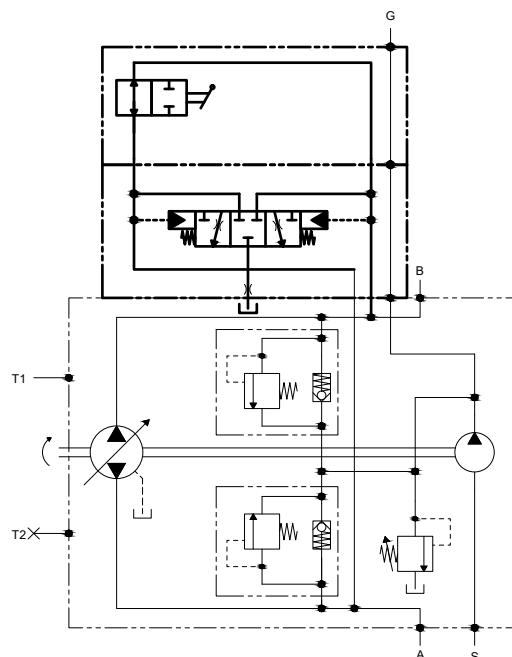

OPTIONAL SB

SCREW BY-PASS

Manual valve to connect the A+B ports together for free rotation of the hydraulic motor.

NOTE: not possible with optional SA and SA.C

CLOCKWISE ROTATION CR

COUNTER-CLOCKWISE ROTATION CC

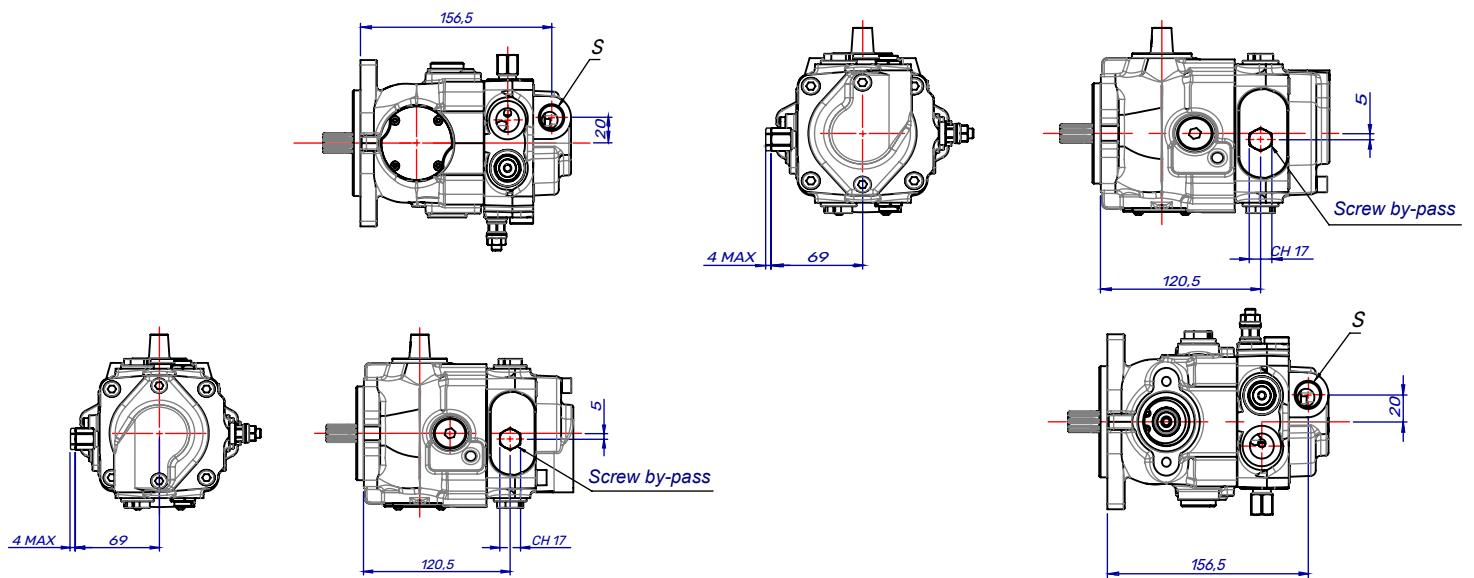

HYDRAULIC CIRCUIT

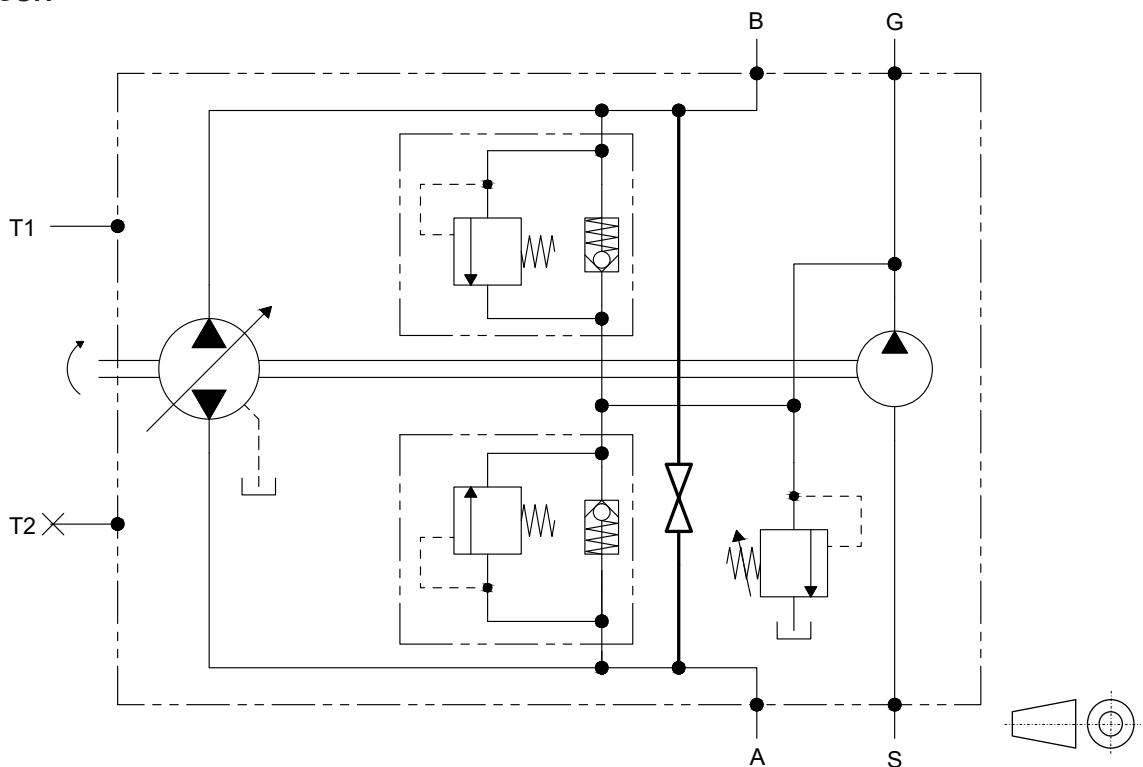

OPTIONAL FB

SAE-A / SAE-B MOUNTING FLANGE (CONVERSION)

Max. torque = 120 Nm

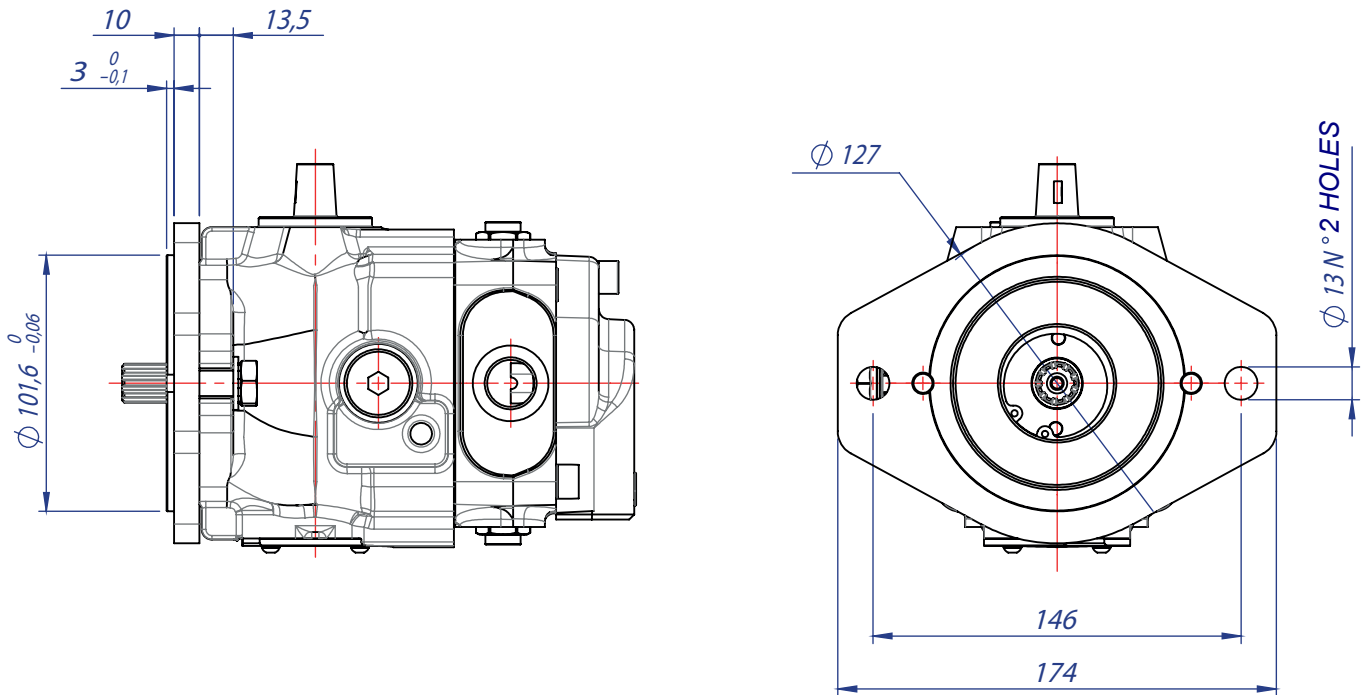

OPTIONAL ST

COUPLING Z = 9 / Z = 13 (SAE-A / SAE-B CONVERSION OF SHAFT)

Max. torque = 120 Nm

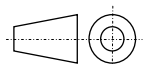
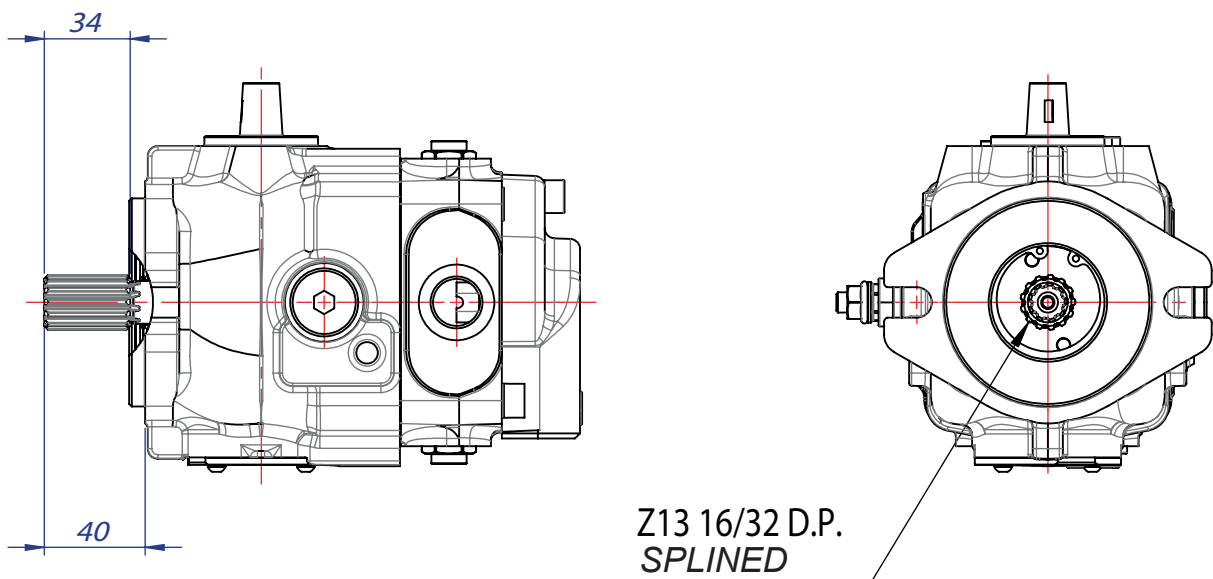

OPTIONAL FBST

SAE-A / SAE-B MOUNTING FLANGE

COUPLING Z = 9 / Z = 13 (SAE-A / SAE-B CONVERSION OF SHAFT)

Max. torque = 120 Nm

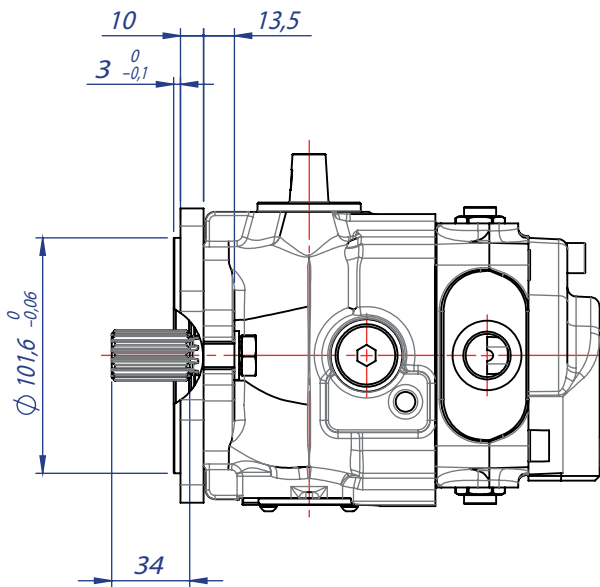

Z13 16/32 D.P.
SPLINED

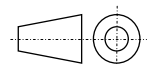
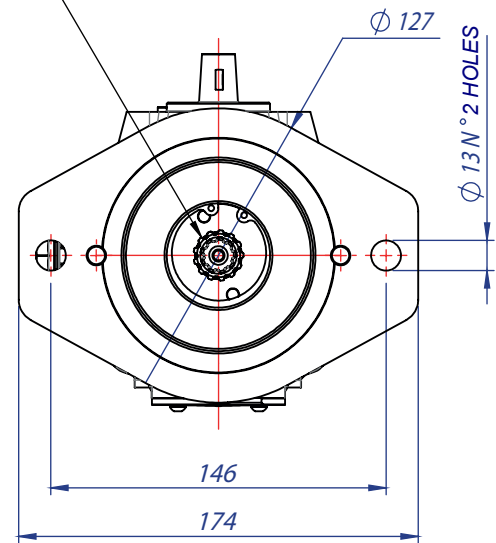

TROUBLESHOOTING

TROUBLES	CAUSE	REMEDY
High noise level	Too high rotation speed of the pump.	Reduce pump rotation speed.
	Wrong rotation direction.	Check the rotation direction of the pump.
	Obstruction in suction line - air in the suction line - wrong oil viscosity - diameter of suction line too small.	Check oil type and viscosity. Check internal diameter of suction line. Remove restrictions. Check oil level of reservoir. Eliminate air intake.
	Not correct connection of the pump. Not correct diameter of pipes / hoses.	Check the pump connections and the pipe / hose diameters according to notes.
	Vibrations of relief valves .	Check the inlet suction line - Check and replace relief valves.
	Internal parts worn out.	Check and replace.
	Wrong pump connection to the prime mover.	Check connections and rotation of direction.
	Too low rotation speed of the pump.	Increase the pump rotation speed.
Low flow rate	Obstructions in the suction line - wrong viscosity.	Check oil type and viscosity. Check internal diameter of suction line. Remove restrictions. Check oil level of reservoir. Eliminate air intake.
	Low remote control pressure.	Check and adjust.
	High internal leakage.	Check the case drain flow.
	Low rotation speed of the pump.	Increase speed of the pump.
Instable or low pressure	Obstruction of suction line - air in the suction line - wrong oil viscosity - diameter of suction line too small.	Check oil type and viscosity. Check internal diameter of suction line. Remove restrictions. Check oil level of reservoir. Eliminate air intake.
	Vibration of relief valves.	Check the inlet suction line. Check and replace relief valves.
	Internal parts worn out.	Check and replace.
Over heating	High oil temperature at suction inlet.	Check the cooling system.
	Internal parts worn out.	Check - replace.
	Wrong setting of pressure relief valves.	Check - adjust the setting of relief valves.

ACCESSORIES

Hydraulic Gear Pump German Standard B1
Hydraulic Gear Pump German Standard B2
Hydraulic Gear Pump SAE-A Standard



For more detailed information ask for catalogue HT 15 F 20.....

Hydraulic Remote Servo Controls



For more detailed information ask for catalogue HT 73 B 105 0919 E

Electric and Electronic Remote Servo Controls



For more detailed information ask for catalogue HT 73 B 203 0516 E

Belt Drive Support BDS SAE-A / SAE-B

For more detailed information ask

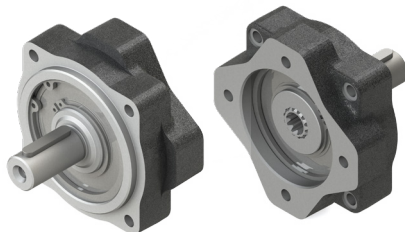

SAE-A

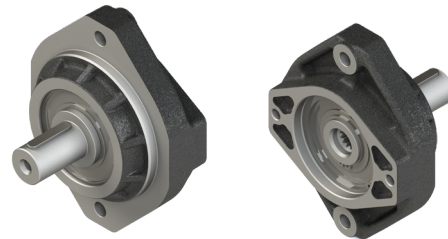

SAE-B

Bell Housings and Couplings for Pump Assembly on Internal Combustion Engines

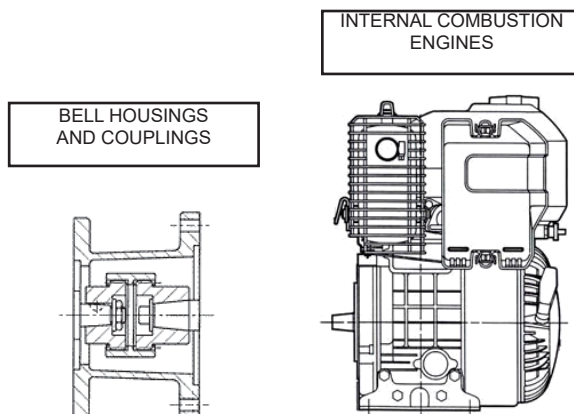

For more detailed information ask our technical department

PUMPS



Closed Loop Axial Piston Pumps (Variable Displacement) - 6-110 cc

Model	Displacement cm ³ /n.	Rated Pressure MPa	Peak Pressure MPa	Maximum speed n/min.	Weight kg (single pump)
TPV 1100 TPV 1300	6, 8, 9, 11, 12, 13	30	35	3.600	8,8
	15, 17		30		
	18		30		
	19, 21	22	28	3.200	
TPV-TPVTC 1500	17, 18, 19, 21	35	40	3.600	14
TPV 3200	21, 28	25	35		22
TPV-TPVT 3600	26, 28, 30, 31, 32, 34, 36, 38, 43	40	45		28
TPV 4300	32, 38, 45, 50	28	35		23
TPV 5000	46, 50, 64	30	40		29
TPV 9000	55	40	45	4.000	55
	72			4.100	68
	90			4.000	
	110			3.800	



Open Loop Axial Piston Pumps (Fixed Displacement) - 32-50 cc

Model	Displacement cm ³ /n.	Rated Pressure MPa	Peak Pressure MPa	Maximum speed n/min.	Weight kg (single pump)
TPF 60	35, 40, 46	35	42	2.800	20,5
	50		41	2.500	



Bent Axis Pumps - 12-130 cc

Model	Displacement cm ³ /n.	Rated Pressure MPa	Peak Pressure MPa	Maximum speed n/min.	Weight kg
TPB - TAP 70	12.6	35	40	3.300	7,5
	17.0			3.200	
	25.4			2.550	8,5
	34.2			2.250	
	41.2, 47.1			2.200	15,5
	56.0			2.100	
	63.6			2.050	
	83.6, 90.7, 108.0			1.700	27,0
	130.0			1.600	29,5

The table values can change in function of the configuration.

As HANSA-TMP has a very extensive range of products and some products have a variety of applications, the information supplied may often only apply to specific situations.

If the catalogue does not supply all the information required, please contact HANSA-TMP.

In order to provide a comprehensive reply to queries we may require specific data regarding the proposed application.

Whilst every reasonable endeavour has been made to ensure accuracy, this publication cannot be considered to represent part of any contract, whether expressed or implied.

The data in this catalogue refer to the standard product. The policy of HANSA-TMP consists of a continuous improvement of its products. It reserves the right to change the specifications of the different products whenever necessary and without giving prior information.



HANSA-TMP S.r.l.
Via M. L. King, 6 – 41122 Modena (ITALY)
Tel.: +39 059 415 711
Fax: +39 059 415 730
hansatmp@hansatmp.it
www.hansatmp.com

Certified Company
ISO 9001:2015 – ISO 14001:2015



Share Capital: € 300.000,00
VAT Number: IT01167360369
REA Number: MO-225785