

–weishaupt–

manual

Installation and operating instruction

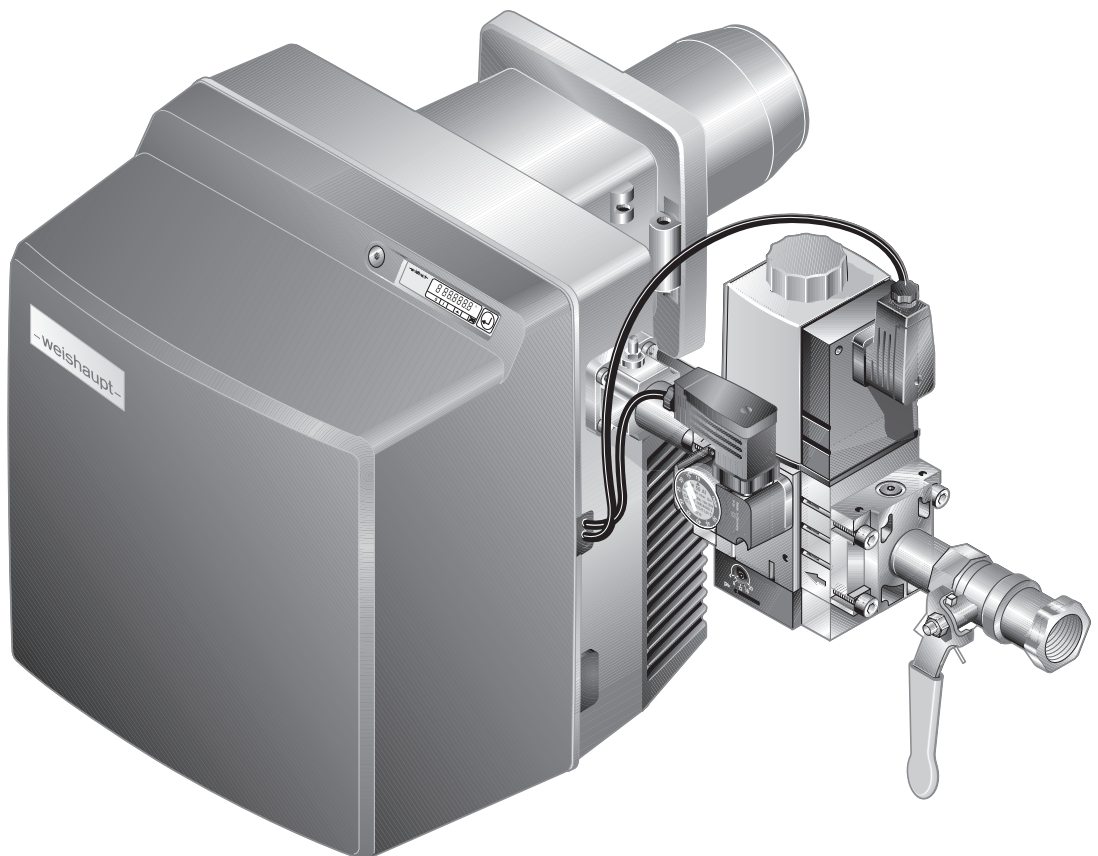

1	User instructions	5
1.1	Target group	5
1.2	Symbols	5
1.3	Guarantee and Liability	6
2	Safety	7
2.1	Designated application	7
2.2	When gas can be smelled	7
2.3	Safety measures	7
2.3.1	Normal operation	7
2.3.2	Electrical connection	8
2.3.3	Gas supply	8
2.4	Alterations to the construction of the equipment	8
2.5	Noise emission	8
2.6	Disposal	8
3	Product description	9
3.1	Type key	9
3.2	Serial number	10
3.3	Function	11
3.3.1	Air supply	11
3.3.2	Gas supply	12
3.3.3	Electrical components	14
3.3.4	Inputs and outputs	15
3.3.5	Program sequence	16
3.4	Technical data	18
3.4.1	Approval data	18
3.4.2	Electrical data	18
3.4.3	Ambient conditions	18
3.4.4	Fuels	18
3.4.5	Emissions	18
3.4.6	Rating	19
3.4.7	Dimensions	20
3.4.8	Weight	20
4	Installation	21
4.1	Installation conditions	21
4.2	Burner installation	22
4.2.1	Rotate burner by 180° (optional)	23
5	Installation	24
5.1	Gas supply	24
5.1.1	Installing the gas valve train	25
5.1.2	Carry out soundness test of gas supply line and vent	27
5.2	Electrical connection	28
6	Operation	30
6.1	Operating panel	30
6.2	Display	32
6.2.1	Info level	33

	6.2.2 Service level	34
	6.2.3 Parameter level	35
	6.2.4 Access level	37
	6.3 Linearisation	38
7	Commissioning	39
	7.1 Prerequisite	39
	7.1.1 Connect measuring devices	40
	7.1.2 Check gas connection pressure	41
	7.1.3 Check soundness of gas valve train	42
	7.1.4 Purging the gas valve train	45
	7.1.5 Preset pressure regulator	46
	7.1.6 Setting values	48
	7.1.7 Preset gas and air pressure switch	49
	7.2 Adjusting the burner	50
	7.2.1 Burner without variable speed drive	50
	7.2.2 Burner with variable speed drive (optional)	56
	7.3 Set pressure switches	64
	7.3.1 Set gas pressure switch	64
	7.3.2 Set air pressure switch	65
	7.4 Concluding work	65
	7.5 Check combustion	66
	7.6 Calculate gas throughput	67
	7.7 Subsequent optimisation of operating points	68
8	Shutdown	69
9	Servicing	70
	9.1 Notes on servicing	70
	9.2 Service plan	72
	9.3 Removing and refitting mixing head	73
	9.4 Set mixing head	74
	9.5 Set ionisation and ignition electrodes	75
	9.6 Service position	76
	9.7 Removing and refitting fan wheel	77
	9.8 Remove burner motor	78
	9.9 Removing and refitting air damper actuator	79
	9.10 Removing and refitting angle drive	80
	9.11 Removing and refitting gas butterfly valve actuator	81
	9.12 Replacing double gas valve coil	82
	9.13 Replace breather plug of multifunction assembly	83
	9.14 Removing and refitting filter insert of multifunction assembly	84
	9.15 Removing and refitting filter insert in gas filter	85
	9.16 Replacing the combustion manager	86
	9.17 Replacing the fuse	89
10	Troubleshooting	90
	10.1 Procedures for fault conditions	90
	10.1.1 Display off	90
	10.1.2 Display OFF	90

10.1.3	Display flashes	91
10.1.4	Detailed fault codes	92
10.2	Rectifying faults	93
10.3	Operating problems	97
11	Technical documentation	98
11.1	Program sequence	98
11.2	Conversion table unit of pressure	100
11.3	Appliance categories	100
12	Project planning	104
12.1	Additional requirements	104
13	Spares	106
14	Notes	124
15	Key word index	125

Translation of original
operating instructions

1 User instructions

This manual forms part of the equipment and must be kept on site.
Carefully read the manual prior to working on the unit.

1.1 Target group







The manual is intended for the operator and qualified personnel. They should be observed by all personnel working with the unit.

Work on the unit must only be carried out by personnel who have the relevant training and instruction.

Persons with limited physical, sensory or mental capabilities may only work on the unit if they are supervised or have been trained by an authorised person.

Children must not play with the unit.

1.2 Symbols

 DANGER	Immediate danger with high risk. Non observance can lead to serious injury or death.
 WARNING	Danger with medium risk. Non observance can lead to environmental damage, serious injury or death.
 CAUTION	Danger with low risk. Non observance can cause damage to the equipment and injury to personnel.
	Important information
	Requires direct action
	Result after an action
	Itemisation
...	Range of values

1 User instructions

1.3 Guarantee and Liability

Guarantee and liability claims for personal and equipment damage are excluded, if they can be attributed to one or more of the following causes:

- non approved application,
- non-observance of the manual,
- operation with faulty safety equipment,
- continual operation despite a fault,
- improper installation, commissioning, operation and service,
- repairs, which have been carried out incorrectly,
- the use of non original Weishaupt parts,
- force majeure,
- unauthorised modifications made to the unit,
- the installation of additional components, which have not been tested with the unit,
- the installation of combustion chamber inserts, which impede full flame formation,
- unsuitable fuels,
- defects in the inlet lines.

2 Safety

2.1 Designated application

The burner is suitable for operation on heat exchangers to EN 303 and EN 676.

If the burner is not used on combustion chambers to EN 303 and EN 676, a safety assessment of combustion and flame stability during individual process conditions and of the shutdown limits of the combustion plant has to be carried out and documented.

The combustion air must be free from aggressive compounds (e.g. Halogens). If the combustion air in the boiler room is contaminated, increased cleaning and servicing will be required. In this case ducted air intake is recommended.

The burner should only be used in enclosed rooms.

Improper use could:

- endanger the health and safety of the user or third parties,
- cause damage to the unit or other material assets.

2.2 When gas can be smelled

Avoid open flames and spark generation, for example:

- do not operate light switches,
- do not operate electronic equipment,
- do not use mobile telephones.
- ▶ Open doors and windows.
- ▶ Close gas isolating valve.
- ▶ Warn the inhabitants, do not ring door bells.
- ▶ Leave the building.
- ▶ Inform the heating contractor or gas supplier from outside of the building.

2.3 Safety measures

Safety relevant fault conditions must be eliminated immediately.

Components, which show increased wear and tear or whose design lifespan is or will be exceeded prior to the next service should be replaced as a precaution.

The design lifespan of the components is listed in the service plan [ch. 9.2].

2.3.1 Normal operation

- All labels on the unit must be kept in a legible condition.
- Stipulated settings, service and inspection work should be carried out at regular intervals.
- Only operate the unit with its cover closed.

2 Safety

2.3.2 Electrical connection

For work carried out on live components:

- Observe the accident prevention instructions DGUV Regulation 3 and adhere to local directives,
- tools in accordance with EN 60900 should be used.

2.3.3 Gas supply

- Only the gas supply company or an approved agent may carry out installation, alteration and maintenance work on gas appliances in buildings and properties.
- Pipework must be subject to a combined load and valve proving test and/or usability testing relative to the pressure range intended, e. g. DVGW-TRGI, worksheet G 600.
- Inform the gas supply company about the type and size of plant prior to installation.
- Local regulations and guidelines must be observed during installation, e. g. DVGW-TRGI, worksheet G 600; TRF Band 1 and Band 2.
- The gas supply pipework should be suitable for the type and quality of gas and should be designed in such a way that it is not possible for liquids to form, e. g. condensate. Observe vaporisation pressure and vaporisation temperature of liquid petroleum gas.
- Use only tested and approved sealing materials, whilst observing all process information.
- Re-commission the appliance when changing to a different type of gas. Changing from LPG to Natural Gas and visa versa requires a conversion.
- Carry out soundness test after each service and fault rectification.

2.4 Alterations to the construction of the equipment

All conversions require written approval from Max Weishaupt GmbH.

- No additional components may be fitted, which have not been tested for use with the equipment.
- Do not use combustion chamber inserts, which hinder flame burnout.
- Use only original Weishaupt replacement parts.

2.5 Noise emission

The noise emissions are determined by the acoustic behaviour of all components fitted to the combustion system.

Prolonged exposure to high noise levels can lead to loss of hearing. Provide operating personnel with protective equipment.

Noise emissions can further be reduced with a sound attenuator.

2.6 Disposal

Dispose of all materials and components in a safe and environmentally friendly way at an authorised location. Observe local regulations.

3 Product description

3.1 Type key

WG40N/1-A ZM-LN

W	Type: W burner
G	Fuel: Gas
40	Size
N	N: Natural Gas F: Liquid Petroleum Gas
1	Ratings size
A	Construction
ZM	Version: modulating
LN	Version: LowNO _x

3 Product description

3.2 Serial number

The serial number on the name plate identifies the product. This is required by Weishaupt's customer service department.

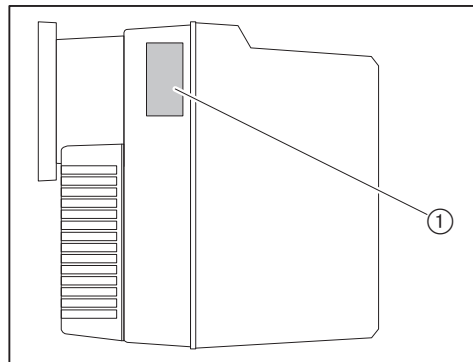

① Name plate

Ser.No. _____

3.3 Function

3.3.1 Air supply

Air damper

The air damper regulates the air quantity required for combustion. The combustion manager drives the air damper via actuator.

At burner shutdown the the actuator automatically closes the air damper. At burner shutdown the air dampers close automatically.

Fan wheel

The fan wheel supplies the air from the air intake housing to the combustion head.

Diffuser

The air gap between flame tube and diffuser is adjusted by positioning the diffuser. This adjusts the mixing pressure and the air quantity required for combustion.

Air pressure switch

The air pressure switch monitors the fan pressure. If the fan pressure is insufficient, the combustion manager initiates a lockout.

3 Product description

3.3.2 Gas supply

Gas isolating valve ①

The gas isolating valve opens and shuts off the gas supply.

Multifunction assembly ⑧

The multifunction assembly contains:

- Gas filter
- Double gas valve
- Pressure regulators

Gas filter ②

The gas filter protects the subsequent valve train components from foreign particles.

Double gas valve ④

The double gas valve opens and shuts off the gas supply.

Pressure regulator ③

The pressure regulator reduces the connection pressure and ensures a constant setting pressure.

Gas butterfly valve ⑤

The gas butterfly valve regulates the gas quantity depending on the rating required. The combustion manager drives the gas butterfly valve via actuator.

Low gas pressure switch/ valve proving gas pressure switch ⑦

The gas pressure switch monitors the gas connection pressure. If the preset pressure is not achieved, the combustion manager initiates a safety shutdown.

The gas pressure switch also monitors if the gas valves are tight. It signals the combustion manager if the pressure increases or decreases to an impermissible level during valve proving.

Valve proving is carried out automatically by the combustion manager:

- after every controlled shutdown,
- prior to burner start following lockout or power outage.

1. Test phase (function sequence for valve proving valve 1):

- Valve 1 closes,
- valve 2 closes after a delay,
- the gas escapes and the pressure between valve 1 and valve 2 reduces,
- both valves remain closed for 8 seconds.

If the pressure increases to above the value set during these 8 seconds, valve 1 is leaking. The combustion manager initiates a controlled shutdown.

2. Test phase (function sequence for valve proving valve 2):

- Valve 1 opens, valve 2 remains closed,
- pressure between valve 1 and valve 2 increases,
- valve 1 closes again,
- both valves remain closed for 16 seconds.

If the pressure decreases to below the value set during these 16 seconds, valve 2 is leaking. The combustion manager initiates a controlled shutdown.

High gas pressure switch ⑥ (optional)

Depending on the burner application, optional equipment may be required for optimum operation [ch. 12.1].

The high gas pressure switch monitors the setting pressure. If the setting pressure exceeds the value set, the combustion manager initiates a controlled shutdown.

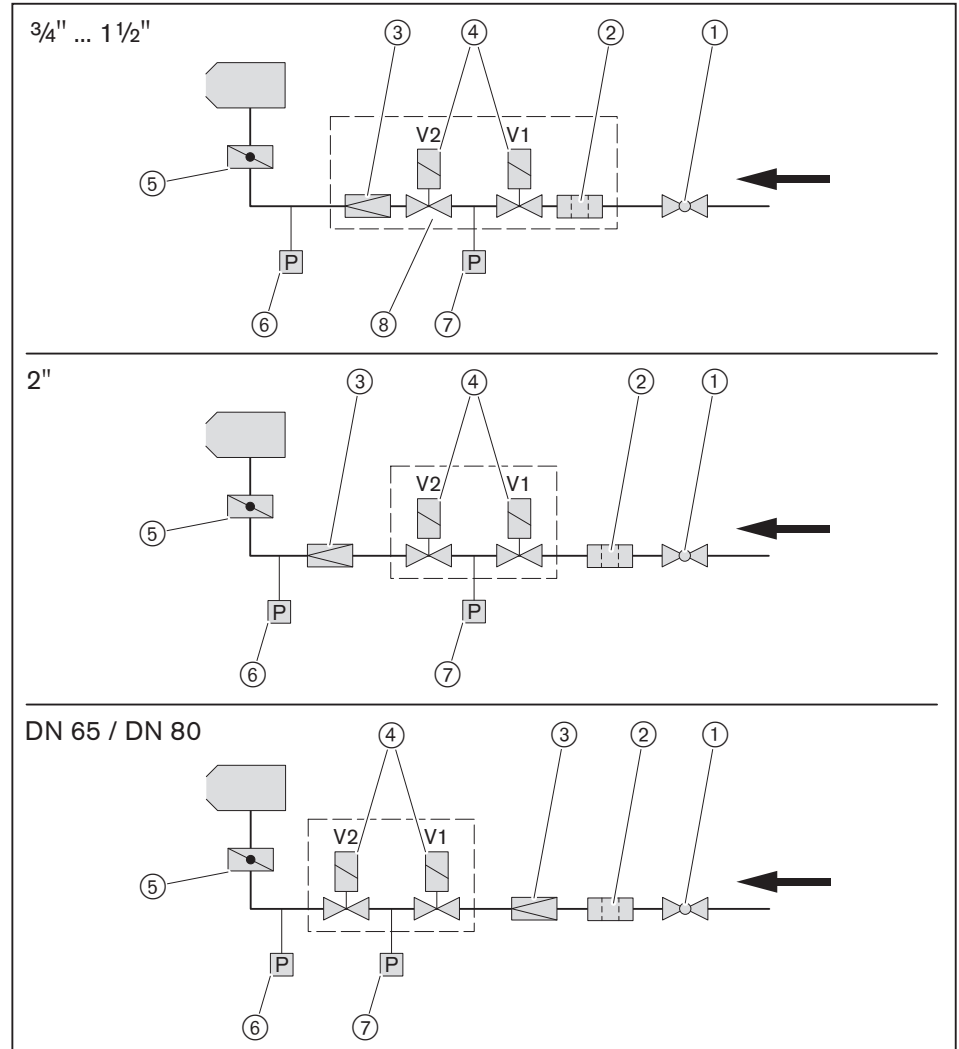

3 Product description

3.3.3 Electrical components

Combustion Manager

The combustion manager W-FM is the control unit of the burner. It controls the sequence of operation and monitors the flame.

Operating panel

The values and parameters of the combustion manager can be displayed and changed at the operating panel.

Burner motor

The burner motor drives the fan wheel. With variable speed drive, a frequency converter is connected upstream.

Ignition unit

The electronic ignition unit creates a spark at the electrode, which ignites the fuel/air mixture.

Ionisation electrode

The combustion manager monitors the flame signal via the ionisation electrode. If the flame signal becomes too weak, the combustion manager carries out a controlled shutdown.

3.3.4 Inputs and outputs

Observe wiring diagram supplied.

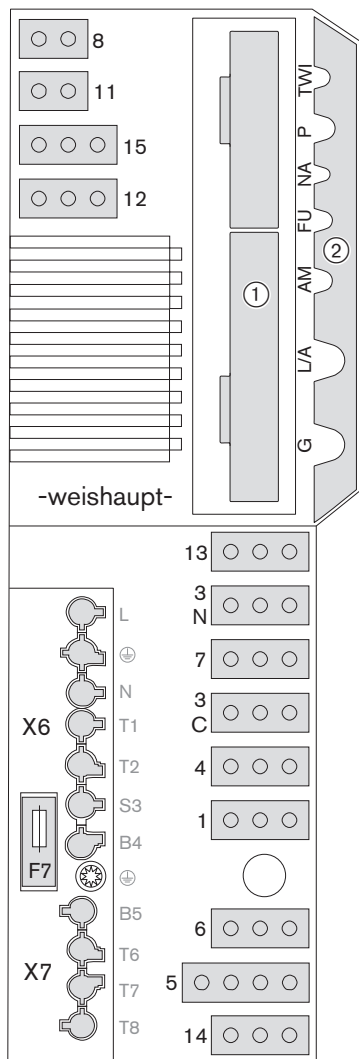

TWI	TWI interface (VisionBox, accessory)
P	O ₂ sensor (accessory)
NA	Speed signal (Namur)
FC	Frequency converter
AM	Operating panel
L/A	Air damper actuator
G	Gas butterfly valve actuator
①	Slot for analogue module EM3/3 or fieldbus module EM3/2
②	W-FM cover
1	External valve LPG
3C	Burner motor or frequency converter for continuous running fan
3N	Burner motor or frequency converter
4	Ignition unit
5	Multifunction assembly or double gas valve
6	not used
7	Bridging plug No. 7
8	Gas meter (impulse generator)
11	Air pressure switch / air pressure switch for ducted air intake (LDW2)
12	Low gas pressure switch/valve proving gas pressure switch
13	Ionisation
14	Remote reset or low gas pressure switch (optional)
15	Bridging plug No. 15 or high gas pressure switch
X6	7 pole connection plug
X7	4 pole connection plug
F7	Internal unit fuse (T6.3H, IEC 127-2/5)

3 Product description

3.3.5 Program sequence

The operating phases for commissioning the burner are shown on the display.

Phase	Function
TEST	After the power supply has been switched on the combustion manager performs a self-test.
G L	At heat demand, the actuators for the air damper and the gas butterfly valve drive to the reference point.
1	The combustion manager monitors for extraneous light.
2	The air damper actuators drives to pre-purge (operating point P9). The gas butterfly valve actuator drives to ignition position (operating point P0).
3	Pre-purge is initiated. The air pressure switch reacts.
4	Pre-purge. The remaining pre-purge time is displayed.
5	The air damper actuator drives to ignition position (operating point P0).
6	Gas valve 1 opens. The gas pressure switch reacts. Ignition starts.
7	Gas valve 2 opens. The fuel is released. The safety time begins. The display shows symbol  .
8	Flame stabilisation.
9	The actuators for the air damper and gas butterfly valve drive to partial load.
10	The burner is in operation. Load control is activated.
11	If heat demand is no longer available, the actuators for air damper and gas butterfly valve drive to partial load. Valve proving starts. 1. Test phase (function sequence for valve proving valve 1): <ul style="list-style-type: none"> ▪ Valve 1 closes, ▪ valve 2 closes after a delay, ▪ the gas escapes and the pressure between valve 1 and valve 2 reduces.
12	Test time valve 1.
13	2. Test phase (function sequence for valve proving valve 2): <ul style="list-style-type: none"> ▪ Valve 1 opens, valve 2 remains closed, ▪ pressure between valve 1 and valve 2 increases, ▪ valve 1 closes again.
14	Test time valve 2.
15	Following the post-purge phase the burner motor switches off. The air damper and gas butterfly valve actuators close.
OFF	Standby, no heat demand.

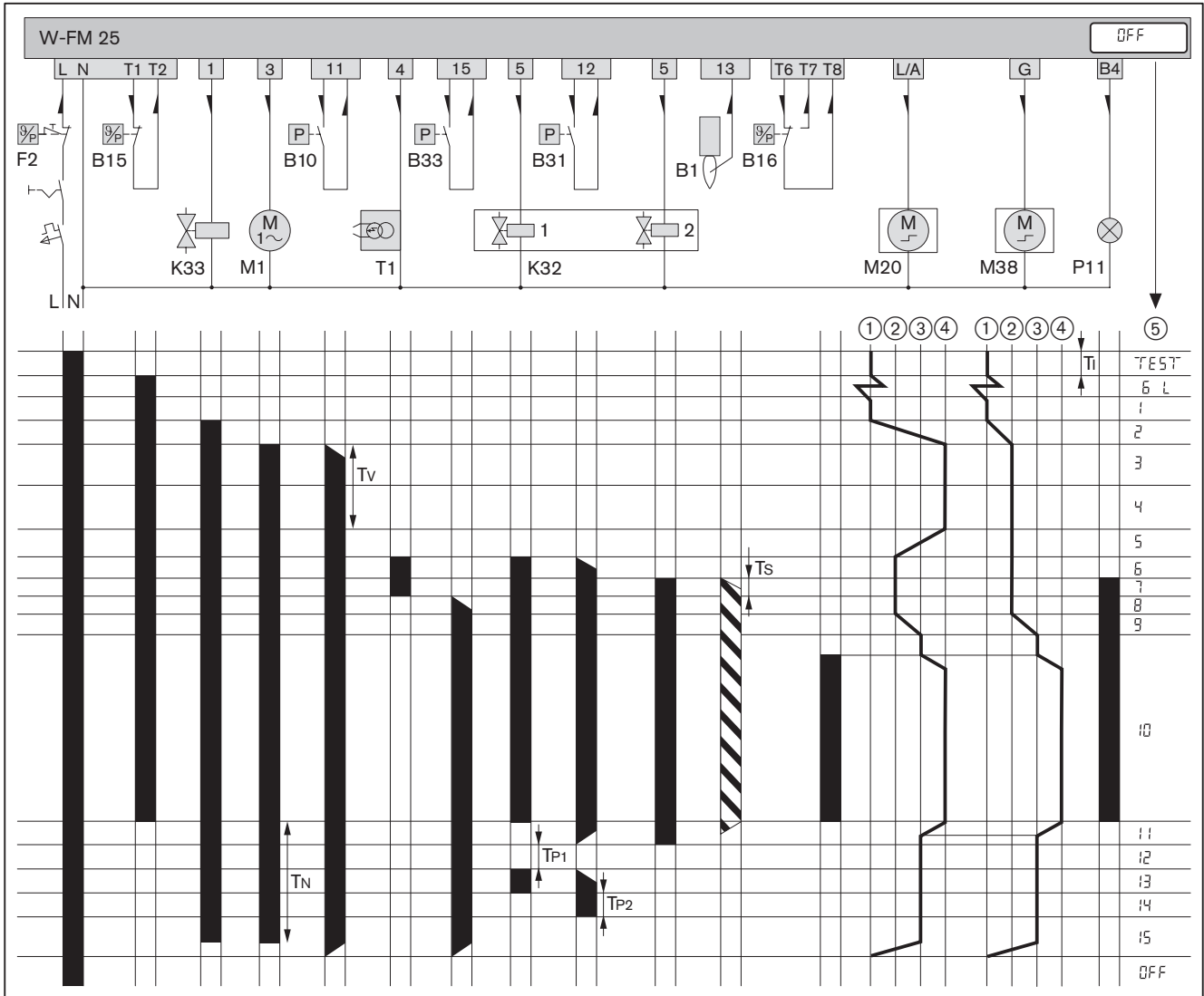

- | | | | |
|-----|---|-----------------|---|
| B1 | Ionisation electrode | ① | CLOSED position |
| B10 | Air pressure switch | ② | Ignition position |
| B15 | Temperature or pressure regulator | ③ | Partial load |
| B16 | Temperature or pressure regulator full load | ④ | Full load |
| B31 | Low gas pressure switch/valve proving gas pressure switch | ⑤ | Operating phase |
| B33 | High gas pressure switch (optional) | T _i | Initialisation time (Test): 3 s |
| F2 | Temperature or pressure limiter | T _N | Post-purge time: 2 s [ch. 6.2.3]. |
| K32 | Double gas valve | TP ₁ | 1. Test phase: 8 s (valve proving valve 1) |
| K33 | External valve LPG | TP ₂ | 2. Test phase: 16 s (valve proving valve 2) |
| M1 | Burner motor | T _v | Pre-purge time: 20 s |
| M20 | Air damper actuator | T _s | Safety time: 3 s |
| M38 | Gas butterfly valve actuator | ■ | Voltage is applied |
| P11 | Control lamp operation (optional) | ▨ | Flame signal present |
| T1 | Ignition unit | → | Current path |

3 Product description

3.4 Technical data

3.4.1 Approval data

PIN (EU) 2016/426	CE-0085AS0311
PIN 2014/68/EU	Z-IS-TAF-MUC-14-05-376456-004
Basic standards	EN 676:2008 Additional standards, see EU conformity certification.

3.4.2 Electrical data

Mains voltage / mains frequency	230 V/50 Hz
Consumption at start	max 856 W
Consumption during operation	max 756 W
Power consumption	max 3.8 A
Internal unit fuse	T6.3H, IEC 127-2/5
External fuse	max 16 AB

3.4.3 Ambient conditions

Temperature in operation	–15 ... +40 °C
Temperature during transport / storage	–20 ... +70 °C
relative humidity	max 80 %, no dew point

3.4.4 Fuels

- Natural Gas E/LL
- Liquid Petroleum Gas B/P

3.4.5 Emissions

Flue gas

To EN 676 the burner complies with emission class 3.

The NO_x values are influenced by:

- combustion chamber dimensions
- flue gas system
- combustion air (temperature and humidity)
- medium temperature

Sound levels

Dual number noise emission values

Measured sound power level L _{WA} (re 1 pW)	81 dB(A) ⁽¹⁾
Uncertainty value K _{WA}	4 dB(A)
Measured sound pressure level L _{pA} (re 20 µPa)	77 dB(A) ⁽²⁾
Uncertainty value K _{pA}	4 dB(A)

⁽¹⁾ Determined to ISO 9614-2.

⁽²⁾ Determined at 1 metre distance from the front of the burner.

The measured noise levels plus uncertainty values form the upper limit value, which could occur when measuring.

3.4.6 Rating

Combustion heat rating

Natural Gas	55 ... 550 kW
Liquid Petroleum Gas	80 ... 550 kW
Combustion head	WG40/1-LN

Capacity graph

Capacity graph to EN 676.

The capacity data given relates to an installation elevation of 0 m above sea level. For installation elevations above 0 m a capacity reduction of approx. 1 % per 100 m applies.

A limited capacity graph is valid for ducted air intake.

Combustion heat rating at combustion head setting:

	Natural Gas	Liquid Petroleum Gas
Combustion head OPEN	③	⑤
Combustion head CLOSED	④	⑥

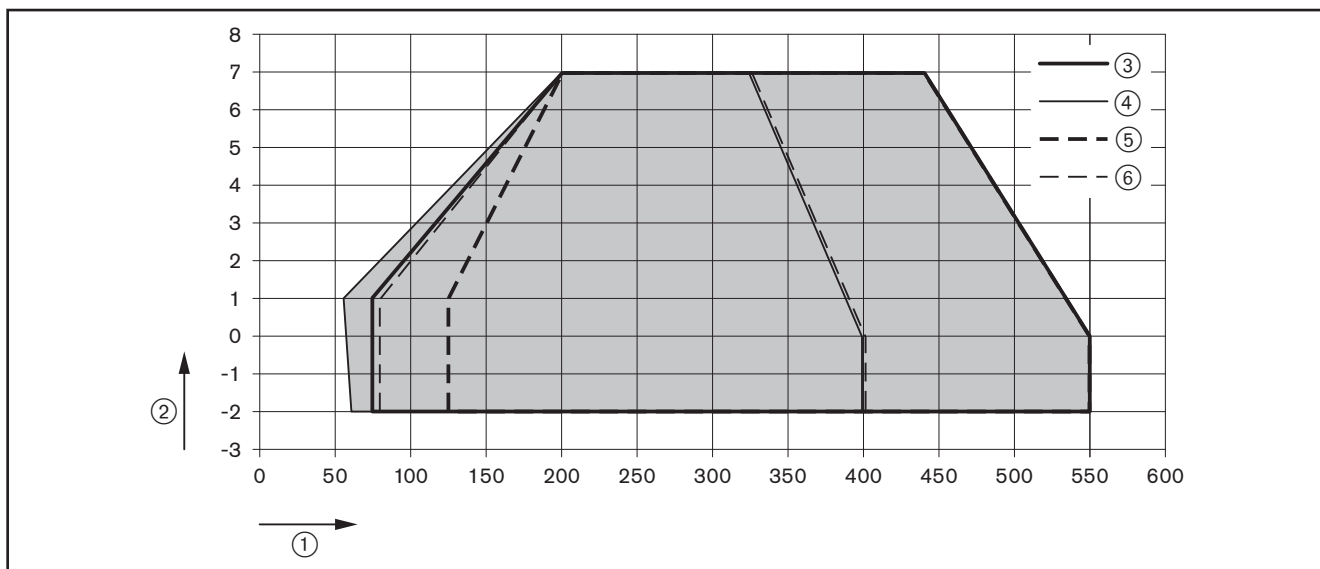

- ① Combustion heat rating [kW]
- ② Combustion chamber pressure [mbar]

3 Product description

3.4.7 Dimensions

Burner

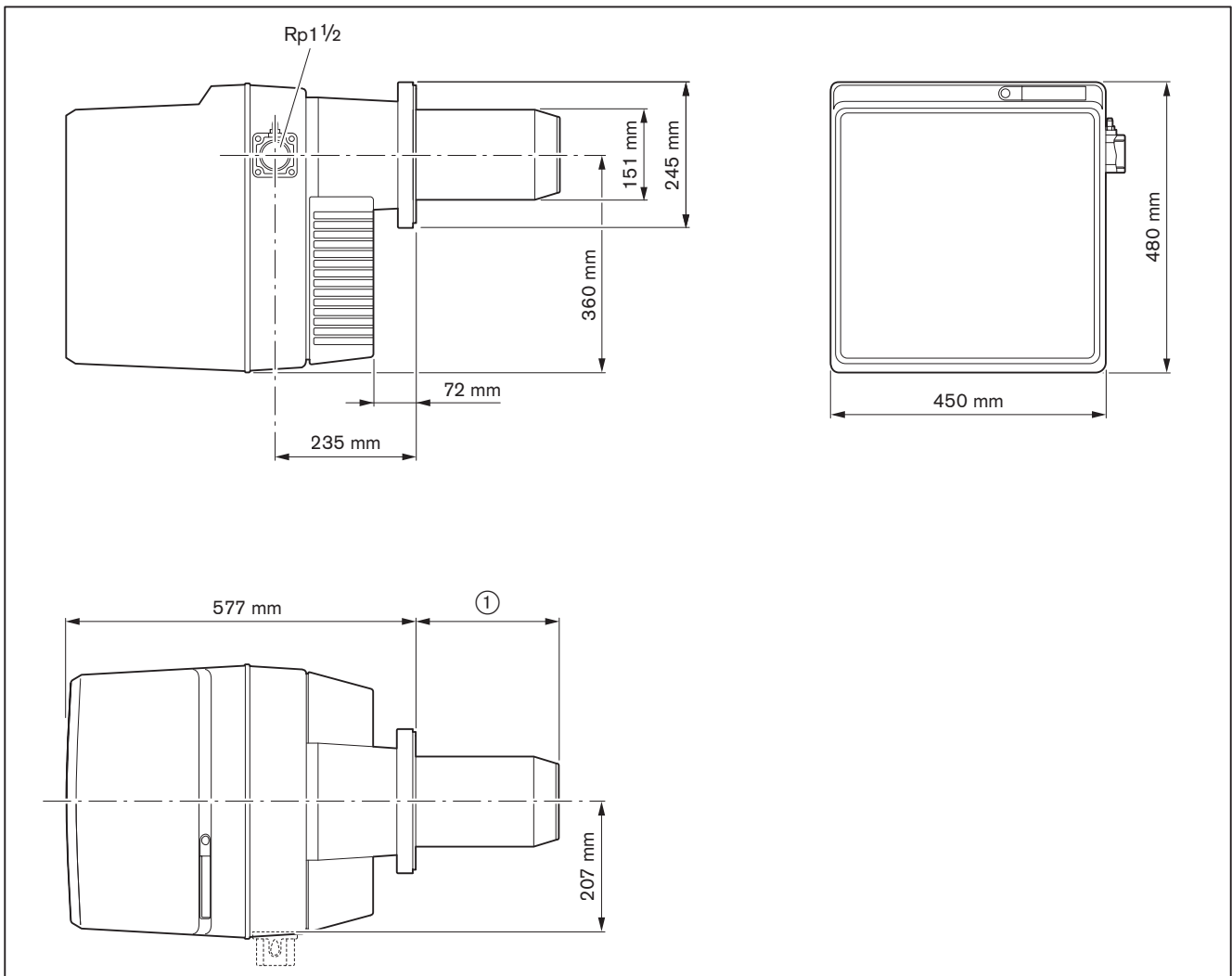

- ① 235 mm without combustion head extension
- 335 mm with combustion head extension (100 mm)
- 435 mm with combustion head extension (200 mm)
- 535 mm with combustion head extension (300 mm)

3.4.8 Weight

approx. 35 kg

4 Installation

4.1 Installation conditions

Burner type and capacity graph

Burner and heat exchanger must be matched.

- ▶ Check burner type and burner capacity.

Installation location

- ▶ Prior to installation ensure that:
 - sufficient space is available for normal and service position [ch. 3.4.7],
 - sufficient combustion air is available, if necessary install ducted air intake,

Prepare heat exchanger

The refractory ③ must not protrude beyond the front edge of the combustion head. The refractory can take a conical shape (min 60°).

Refractory may not be required on boilers with water-cooled front, unless the manufacturer gives other instructions.

Following installation, the aperture ④ between flame tube and refractory should be filled with flame-proof, resilient insulating material. Do not make solid.

Heat exchangers with deep refractories or thick doors, or heat exchangers with reverse flame combustion chambers may require a combustion head extension. Head extensions of 100, 200 and 300 mm are available. Dimension ② then changes according to the head extension used.

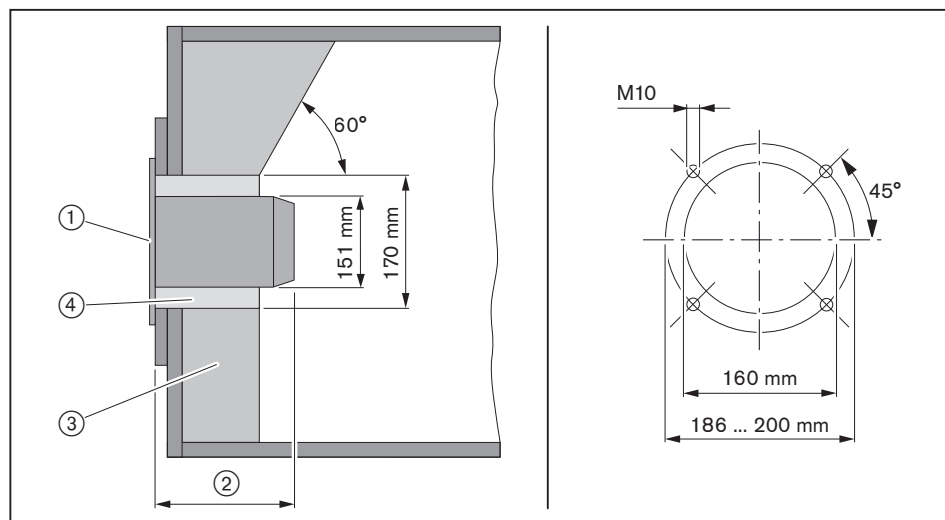

- ① Flange gasket
- ② 235 mm
- ③ Refractory
- ④ Aperture

4 Installation

4.2 Burner installation



Only valid in Switzerland

When installing and operating the regulations of SVGW, VKF, local and Cantonal regulations and the EKAS guideline (LPG Guideline Part 2) must be observed.

- ▶ Remove mixing head [ch. 9.3].
- ▶ Remove burner flange ① from burner housing.



The burner in its standard version is designed for valve train connection from the right. For gas valve train connection from the left the burner has to be installed rotated by 180° [ch. 4.2.1]. To do this, additional conversion measures are required [ch. 5.1.1].

- ▶ Fit flange gasket ② and burner flange ① to the heat exchanger using screws ③.
- ▶ The aperture between combustion head and refractory should be filled with flame-proof, resilient insulating material (do not make solid).

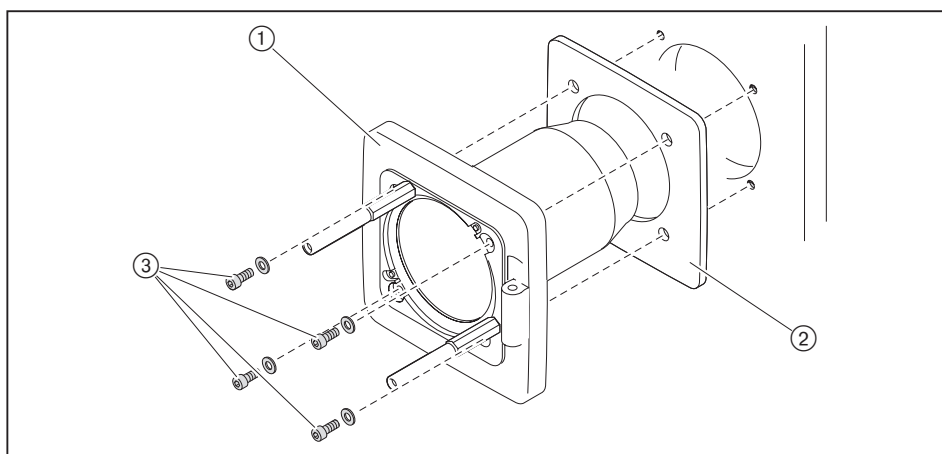

- ▶ Mount burner with screws ① to burner flange.

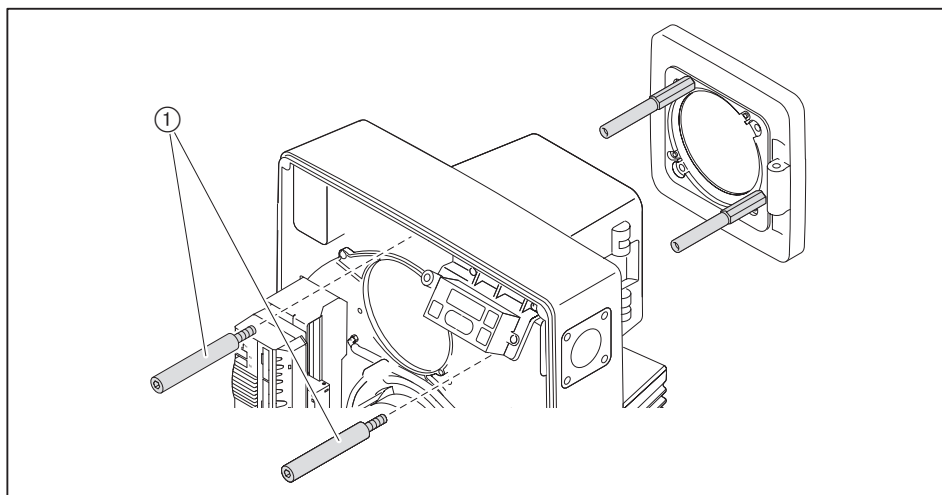

- ▶ Check setting of electrodes [ch. 9.5].
- ▶ Fit mixing head [ch. 9.3].

4.2.1 Rotate burner by 180° (optional)

- ▶ Mount operating panel ① on the opposite side of the housing.
- ▶ Mount fixing bracket ③ on the opposite side of the housing.
- ▶ Rotate burner flange ② 180° and mount with flange gasket.
- ▶ Rotate burner 180° and fit screws ④ to burner flange.
- ▶ The aperture between combustion head and refractory should be filled with flame-proof, resilient insulating material (do not make solid).
- ▶ Check setting of electrodes [ch. 9.5].
- ▶ Fit mixing head [ch. 9.3].

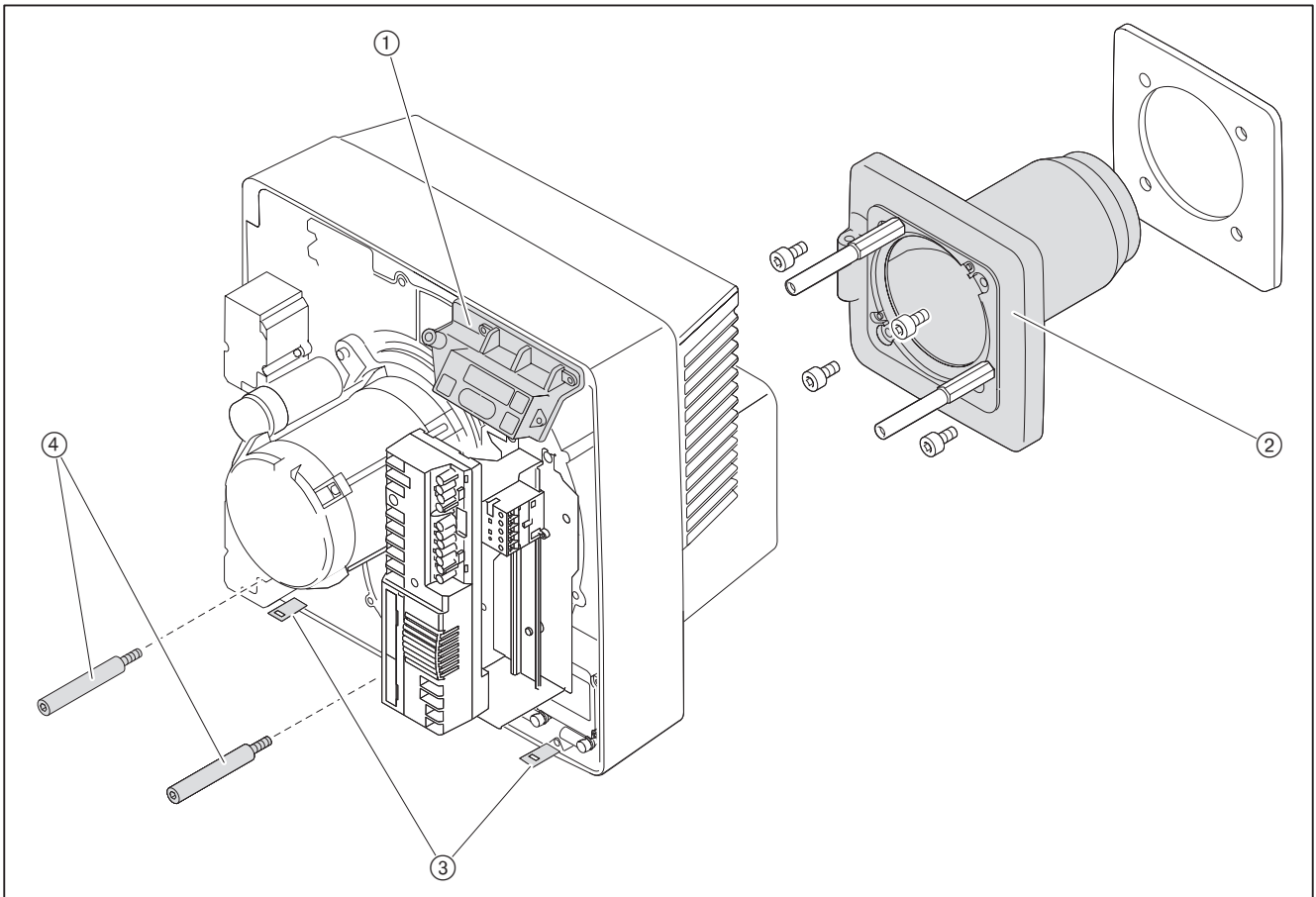

5 Installation

5 Installation

5.1 Gas supply

**Risk of explosion due to leaking gas**

Gas leaks can lead to a build-up of explosive gas/air mixture. With an ignition source present this can result in an explosion.

- ▶ Install gas supply with care.
- ▶ Observe all safety instructions.

Only an approved gas installer may carry out the gas side connection. Observe local regulations.

The following should be obtained from the gas supply company:

- Type of gas
- Gas connection pressure.
- Maximum CO₂ content in the flue gas.
- Calorific value in normal condition [kWh/m³].

Observe maximum permissible pressure of all components of the gas valve train.

- ▶ Close all fuel shut off devices prior to commencing work and protect from accidental re-opening.

General installation instructions

- Install manually operated shut off device (gas isolating valve) in the supply.
- Ensure correct mounting alignment and cleanliness of sealing surfaces.
- Mount valve train free of vibration. It must not be allowed to swing. Suitable supports should be fitted.
- Mount gas valve train free of stresses.
- The distance between burner and Multifunction assembly and/or double gas valve and pressure regulator should be as small as possible. If the distance is too great, it is possible that a gas/air mixture is formed, which will influence burner start.
- Observe sequence and flow direction of gas valve train.
- If necessary, fit thermal shut off device (TAE) in front of the gas isolating valve.

Installation position

Multifunction assembly and/or double gas valve and pressure regulator can be installed with the axis standing vertical to lying horizontal.

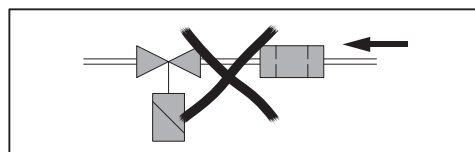

5.1.1 Installing the gas valve train



Only in conjunction with W-MF and gas connection pressure > 150 mbar

If the gas connection pressure is > 150 mbar, a pressure regulator has to be fitted upstream of the W-MF.

- ▶ Install the gas valve train, see additional sheet (Print No. 835109xx).

Installing the valve train from the right

- ▶ Remove protective foil from gas connection flange.
- ▶ Mount gas valve train free from stresses. Do not compensate for installation errors by over-tightening the flange screws.
- ▶ Ensure correct alignment of flange seals.
- ▶ Tighten screws evenly diagonally across.

3/4" ... 1 1/2"

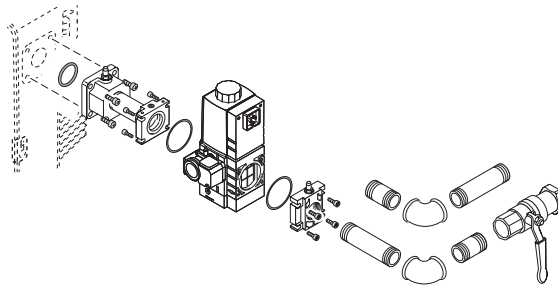

2"

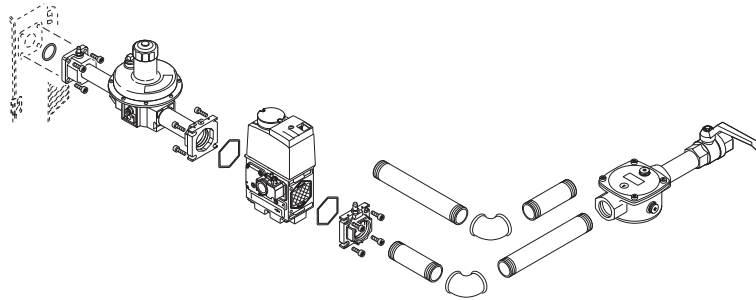

DN 65
DN 80

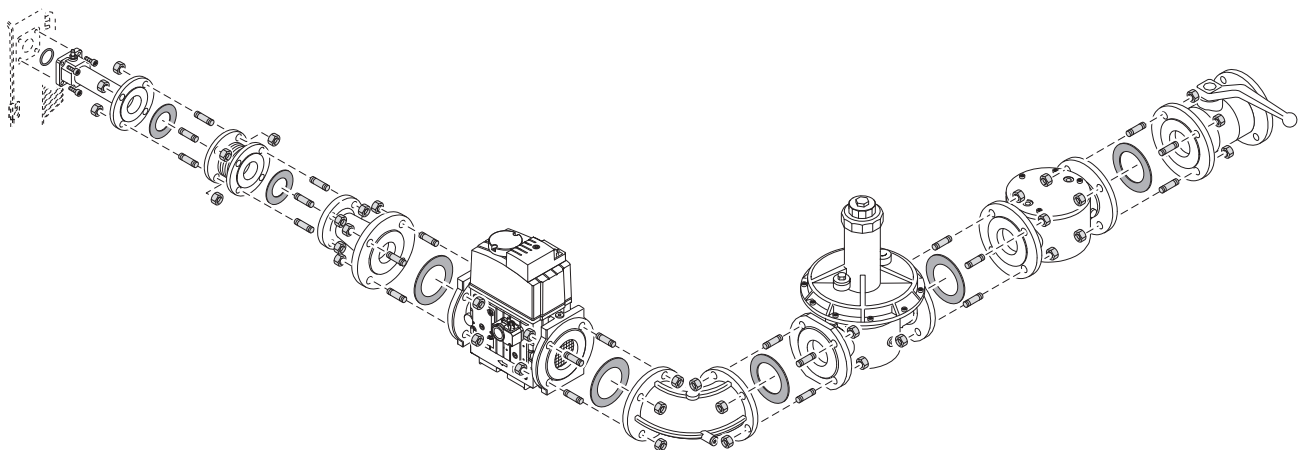

5 Installation

Installing the gas valve train from the left

To fit the gas valve train to the burner from the left, the burner has to be installed rotated by 180°. To do this, additional conversion measures are required.

Move the gas pressure switch prior to installing the multifunction assembly:

- ▶ Remove closing plug ① and gas pressure switch ③.
- ▶ Mount gas pressure switch ③ and O ring ② on the opposite side.
- ▶ Mount closing plug ① on the opposite side.

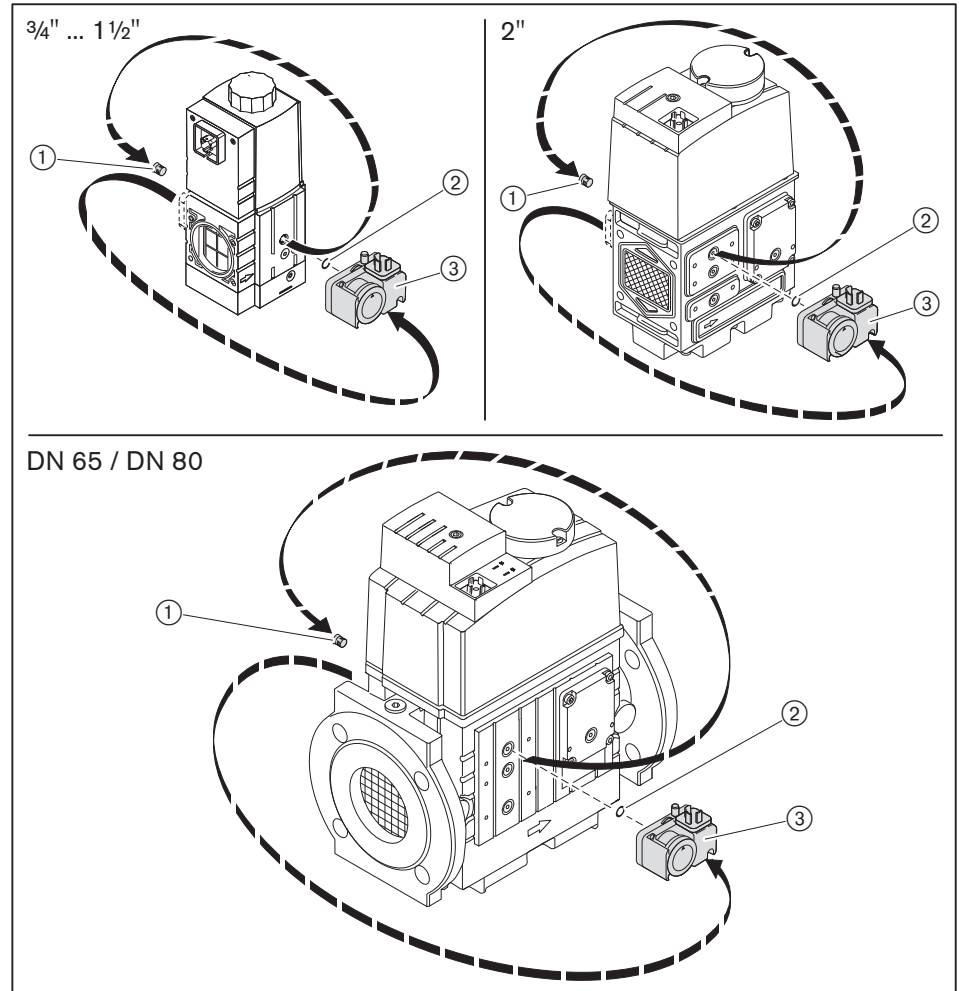

- ▶ Continue installation in the same way as for "Mount gas valve train from the right".

Accessories

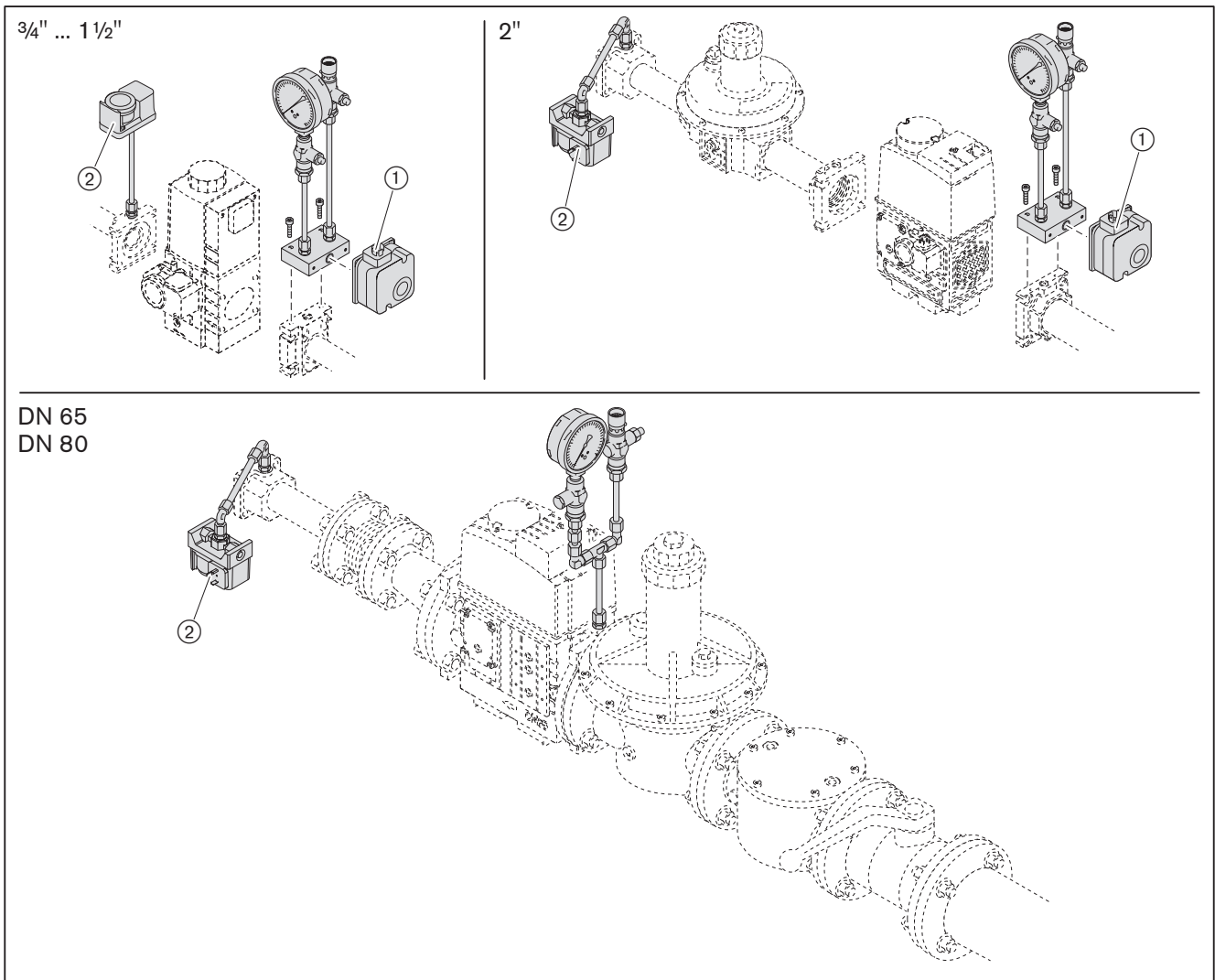

- ① Low gas pressure switch with mechanical interlock (B34)
- ② High gas pressure switch (B33)

5.1.2 Carry out soundness test of gas supply line and vent

Only the gas supply company or a contract installation company may carry out a soundness test and vent the gas line.

5 Installation

5.2 Electrical connection



Risk of electric shock

Working on the device when voltage is applied can lead to electric shock.

- ▶ Isolate the device from the power supply prior to starting any work.
- ▶ Safeguard against accidental restart.



Electric shock caused by frequency converter

It is possible that electrical components continue to carry voltage and cause electric shock even after the voltage supply has been disconnected.

- ▶ Wait approx. 5 minutes before commencing work.
- ✓ Electric voltage has dissipated.

The electrical connection must only be carried out by qualified electricians. Observe local regulations.

Observe wiring diagram supplied.

- ▶ Plug in plug for gas pressure switch ② and double gas valve ③ and secure with screws.
- ▶ Check polarity and wiring of 7 pole connection plug ①.
- ▶ Plug in connection plug ①.
- ▶ Check polarity and wiring of 4 pole connection plug ④.
- ▶ Plug in connection plug ④.

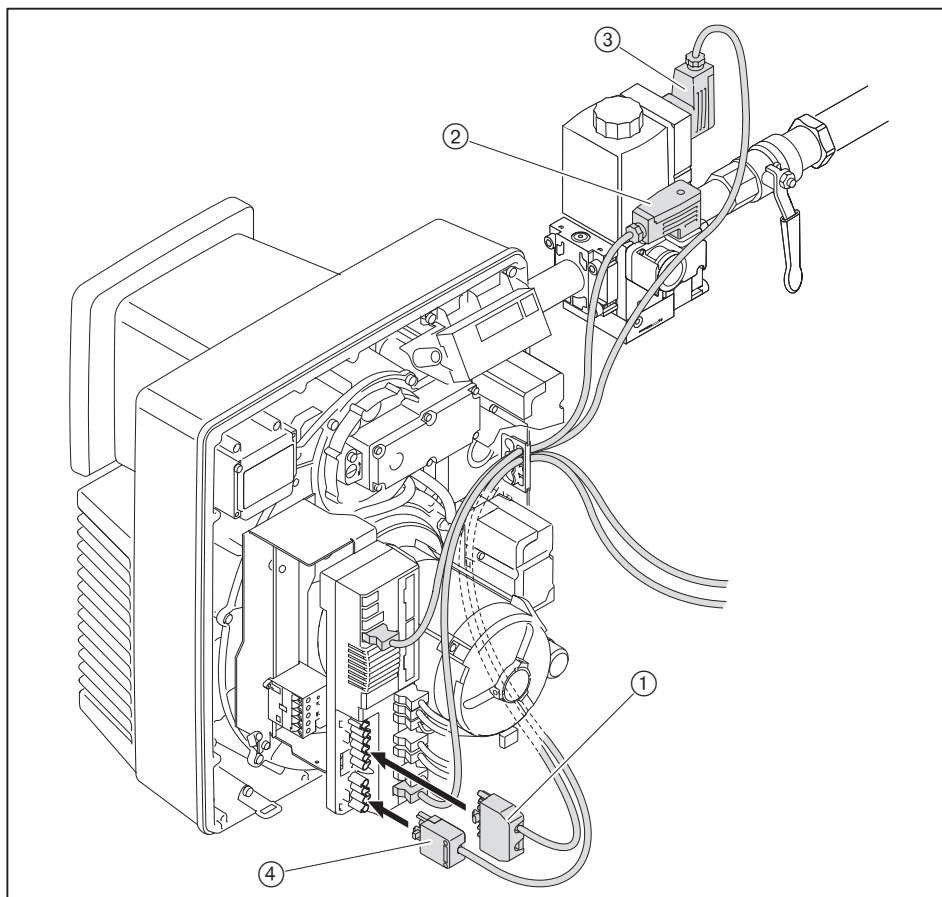

With remote reset, install connection line separately. Do not exceed maximum cable length of 50 metres.

Separate supply line for burner motor (not with variable speed drive)

Observe wiring diagram supplied.

- ▶ Plug supply line for burner motor into connection plug ① of the contactor.

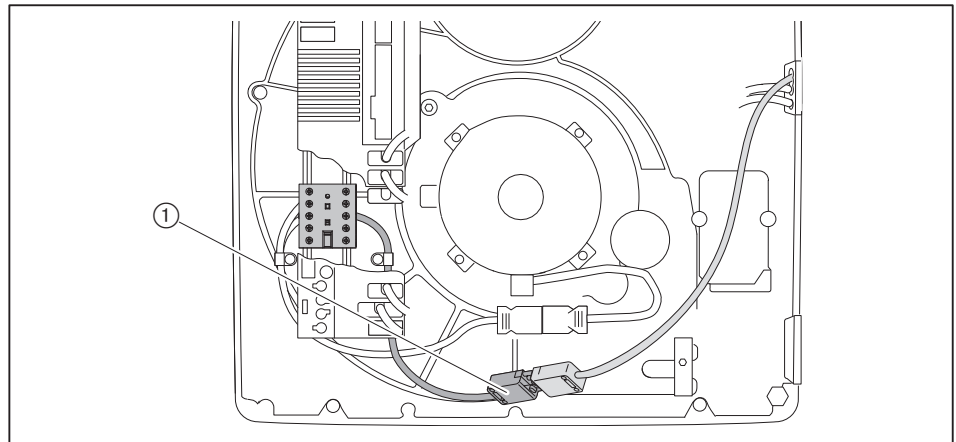

External fuse of separate supply line:

- min 10 AT
- max 16 AT

6 Operation

6 Operation

6.1 Operating panel

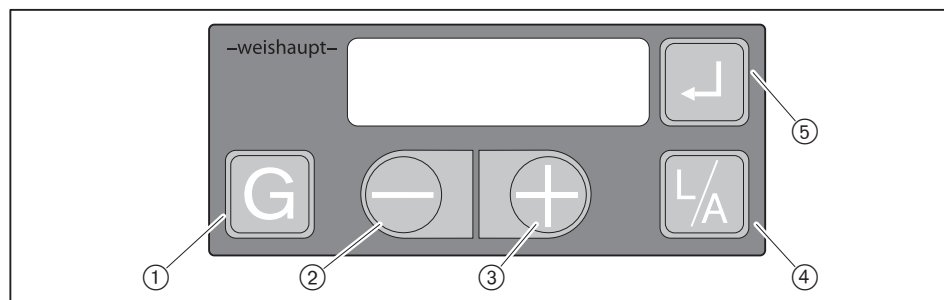

①	[G] Gas	Select gas butterfly valve actuator
②	[-]	Change values
③	[+]	
④	[L/A] Air	Select air damper actuator
⑤	[Enter]	Reset burner: call up information press for approx. 0.5 seconds: Info level press for approx. 2 seconds: Service level
③ and ⑤	[+] and [ENTER]	press simultaneously for approx. 2 seconds: Parameter level (only possible with display OFF)
④ and ⑤	[L/A] and [Enter]	press simultaneously: select fan speed (only in conjunction with variable speed drive)



Various actions are only triggered when the key is released, for example changing the display, reset.

OFF function

- ▶ Press [ENTER], [L/A] and [G] keys simultaneously.
- ✓ Immediate lockout with error 18h.

Operating level

The current actuator position and/or the fan speed can be displayed in the operating level (10).

Displaying gas butterfly valve setting:

- ▶ Press key [G].

Displaying air damper setting:

- ▶ Press key [L/A].

Displaying fan speed:

(only in conjunction with variable speed drive)

- ▶ Press [Enter] and [L/A] simultaneously.

Flame signal

The flame signal can be displayed during commissioning (setting level) by using a combination of keys.

- ▶ Press [Enter], [L/A] and [G] keys simultaneously.
- ✓ The flame signal is displayed.

Recommended flame signal, see Service level information 19 [ch. 6.2.2].

Operating status

The exact operating status of the combustion manager can also be displayed. This simplifies determining the cause of a fault during troubleshooting [ch. 11.1].

- ▶ Press and hold [-] and [+] simultaneously for approx. 3 seconds.
- ✓ The combustion manager changes to operating display. The display shows current operating status with a number.

Back to standard display:

- ▶ Press and hold [-] and [+] simultaneously for approx. 3 seconds.

VisionBox Software

If the VisionBox Software is connected, change-over to the access level must be confirmed via the operating panel.

- ▶ Press [+]
- ✓ Software changes to the access level

6 Operation

6.2 Display

The display shows the current operating statuses and operating data.

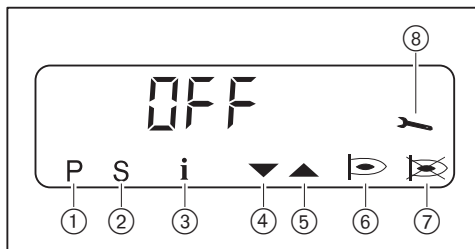

- ① Setting level activated
- ② Start phase activated
- ③ Info level activated
- ④ Actuator runs CLOSED
- ⑤ Actuator runs OPEN
- ⑥ Burner in operation
- ⑦ Lockout
- ⑧ Service level activated

7E57

Combustion manager performs self test [ch. 3.3.5]

OFF

Standby, no heat demand

OFF S

Shutdown via contact X3:7 (plug No. 7)

OFFUPr

Unprogrammed condition or programming not completed

OFF E

Standby, no heat demand, shutdown via fieldbus module

OFF6d

Insufficient gas low gas pressure switch

10

Current operating phase [ch. 3.3.5]

F1

Under-voltage in standby
or internal device error, see error memory

F9

Connection to Fieldbus faulty
Acknowledge error: Press [-] and [+] keys simultaneously.

6.2.1 Info level

Burner data can be interrogated in the Info level .

- ▶ Press [Enter] for approx. 0.5 seconds.
- ✓ The Info level is activated.
- ▶ Press [Enter] to reach the next information.

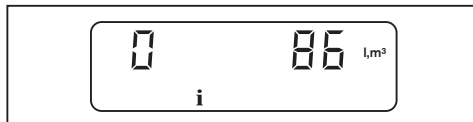

No.	Information
0	Total gas consumption in m ³ (via X3:8) Reset value: ▶ Press [L/A] and [+] simultaneously for approx. 2 seconds.
1	Hours run
2	– no function –
3	Burner starts
4	Device item number
5	Index of device item number
6	Device number
7	Production date (DDMMYY)
8	Fieldbus address
9	Valve proving behaviour
11	Current fan speed (only in conjunction with variable speed drive) Display of standardised speed: ▶ Press key [L/A].
12	Current gas consumption (0.1 m ³ /h)
13	Analogue module EM3/3 or Fieldbus module EM3/2 available 0: no 1: yes

After information 13 or a waiting time of approx. 20 seconds the combustion manager changes over to the operating level.

6 Operation

6.2.2 Service level

The service level gives information about:

- Actuator position of the individual operating points,
 - the most recent fault,
 - flame signal during burner operation.
- ▶ Press [Enter] for approx. 2 seconds.
✓ The service level is activated.
▶ Press [Enter] to reach the next information.

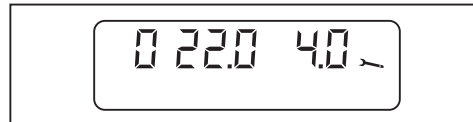

Only in conjunction with variable speed drive

The speed set can be displayed at information 0 ... 9.

Displaying the fan speed:

- ▶ Press key [L/A].

No.	Information
0	Actuator position in operating point P0
1	Actuator position in operating point P1
2	Actuator position in operating point P2
3	Actuator position in operating point P3
4	Actuator position in operating point P4
5	Actuator position in operating point P5
6	Actuator position in operating point P6
7	Actuator position in operating point P7
8	Actuator position in operating point P8
9	Actuator position in operating point P9
10 ... 18	Fault memory most recent fault ... ninth last occurred fault Display additional information: 1. Detailed error codes / operating status: ▶ Press [+] key. 2. Detailed error codes: ▶ Press [-] and [+] keys simultaneously. Repetition counter: ▶ Press key [G].
19	Flame Signal Range: 00 ... 58 <ul style="list-style-type: none"> ▪ < 50: poor quality ▪ 50 ... 58: high quality recommended value: > 50

After information 19 or a waiting time of approx. 20 seconds the combustion manager changes over to the operating level.

6.2.3 Parameter level

The parameter level can only be called up in Standby (OFF) mode.

- ▶ Press [+] and [Enter] keys simultaneously for approx. 2 seconds.
- ✓ The parameter level is activated.



- ▶ Press [+] key.
- ▶ Press [Enter] to reach the next parameter.
- ✓ Only then will the value be stored.

Pno.	Parameters	Setting range	Factory setting
1	Fieldbus address	0 ... 254 / OFF Switch over to OFF and to address: ▶ Briefly press [-] and [+] simultaneously.	OFF
2	Actuator position in Standby	0.0 ... 90.0° Change air damper setting: ▶ Press [L/A] and [+] or [-]. Change gas butterfly valve setting: ▶ Press [G] and [+] or [-]. Change fan speed: (only in conjunction with variable speed drive) ▶ Press [Enter] and [L/A] simultaneously and press [+] or [-].	0.0
3	Function fieldbus module -or- function analogue module	The parameter is dependent on the module used. Setting range of parameters, see installation and operating manual of module. Fieldbus module (response to heat demand): 2: Bus default and control circuit (T1/T2) activated Analogue module: 2: DIP switches activated	2
4	Post-purge time	0 ... 4095 s	2
5	Fault memory	0: fault memory is empty 1: fault memory contains data Delete fault memory: ▶ Press [L/A] and [+] simultaneously for approx. 2 seconds.	-
6	Factor for gas consumption Impulse rate of meter per m ³	1 ... 65535 200 impulses ± 1 m ³ ▶ Adjust factor depending on impulse rate of gas meter.	200
A	Low gas pressure switch/valve proving gas pressure switch (X3:12)	0: not activated 1: Proof-of-closure (valve 1) 2: without low gas pressure switch 3: with low gas pressure switch	3
b	Air pressure switch (X3:11) (display only, no adjustment possible)	0: not activated 1: activated	1
C	Operating mode output X3:1	0: not activated 1: with pilot valve not interrupted 2: with pilot valve interrupted 3: Standard (external LPG valve)	3

6 Operation

Pno.	Parameters	Setting range	Factory setting
d	Flame sensor	0: ionisation electrode / flame sensor FLW 1: switch input (X3:14) 2: flame sensor QRB	0
E	Display mode	0: E-parameter is not activated in the access level 1: E-parameter is activated in the access level Settings 2 and 3 are required for O ₂ trim, see supplementary sheet O ₂ trim W burners (Print No. 835587xx).	0
F	Restart attempts following flame failure	0 ... 1	1
H	Actuator setting for post-purge	0.0 ... 90.0° Change air damper setting: ▶ Press [L/A] and [+] or [-]. Change fan speed: (only in conjunction with variable speed drive) ▶ Press [Enter] and [L/A] simultaneously and press [+] or [-].	0
L	Load shutdown	0.0 ... 4095 seconds If there is no longer a demand for heat, the W-FM reduces the burner capacity and closes the fuel valves after the time set has elapsed. If partial load is reached before the time has elapsed, the fuel valves close immediately.	0
n	Operating mode O ₂ trim (only in conjunction with O ₂ trim)	0: not activated Additional parameters can be displayed with setting 1 ... 4, see supplementary sheet O ₂ trim W burners (Print No. 835587xx).	0

After the last parameter or a waiting time of approx. 20 seconds the combustion manager changes over to the operating level.

6.2.4 Access level

In the access level, the configuration can be adapted relative to the burner type or version.

In the parameter level, the display mode must be configured to 1, to enable access to parameters E0 ... E3 [ch. 6.2.3].

- ▶ Press [G] and [L/A] simultaneously.
- ✓ The access level is activated.



- ▶ Press [+] key.
- ✓ Parameter E0 is displayed.
- ▶ Press and hold [Enter] key and set the parameter using [+] or [-].
- ▶ Press [+] to reach the next parameter.

Parameters	Information	Setting range
E0	Burner type	0: single fuel burner 1: dual fue burner
E1	Operating mode (display only, no adjustment possible)	0: intermittent operation 1: continuous operation
E2	Flame sensor type	0: ionisation electrode / flame sensor FLW 1: switch input (X3:14) 2: flame sensor QRB
E3	Fan configuration	0: Off 1: fan control 2: fan control with fan monitoring 3: VSD 4: fan control according to modulating degree specified 5: DAU control 6 ... 255: off

6 Operation

6.3 Linearisation

During commissioning it is possible to carry out linearisation of the operating points in gas operation.

During linearisation a straight line is generated from the operating point displayed to P9. The values on the straight are adopted as the new operating points.

Initiate a calculation after P9

- ▶ Press [ENTER].
- ✓ Combustion manager changes to linearisation mode.

The linearisation mode can be interrupted using the [-] key.

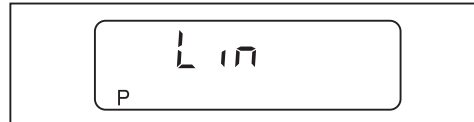

- ▶ Confirm with [+] key.
- ✓ Linearisation is initiated.

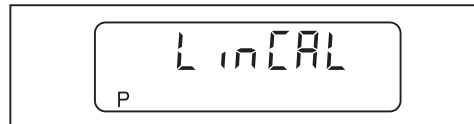

Example:

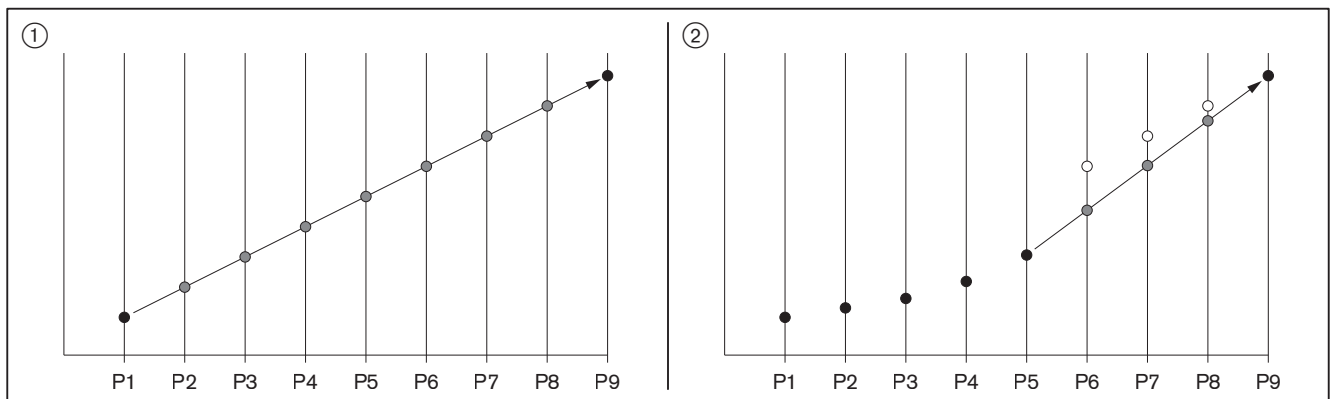

- ① Calculation from P1 to P9
- ② Calculation from P5 to P9

7 Commissioning

7.1 Prerequisite

Commissioning must only be carried out by qualified personnel.

Only correctly carried out commissioning ensures the operational safety.

- ▶ Prior to commissioning ensure that:
 - all assembly and installation work has been carried out correctly,
 - sufficient combustion air is available, if necessary install ducted air intake
 - the annulus between flame tube and heat exchanger is filled
 - the heat exchanger is filled with medium
 - the regulating, control and safety devices are functioning and set correctly
 - the flue gas ducts are unimpeded
 - a measuring point conforming to standards is available to measure the flue gas
 - the heat exchanger and flue gas ducting up to the test point are sound (extraneous air influences the test results)
 - the operating instructions of the heat exchanger are complied with
 - a heat demand is available

Additional system-related tests could be necessary. Please observe the operating guidelines for the individual components.

On installations with process equipment, the conditions for safe operation and commissioning must be met, see worksheet 8-1 (Print No. 831880xx).

7 Commissioning

7.1.1 Connect measuring devices

Measuring device for ionisation current

- ▶ Remove ionisation cable from the plug coupling.
- ▶ Connect current measuring device in series.

Ionisation current

Extraneous light detection from	1 μ A
Minimum ionisation current	5 μ A
Recommended ionisation current	9 ... 15 μ A

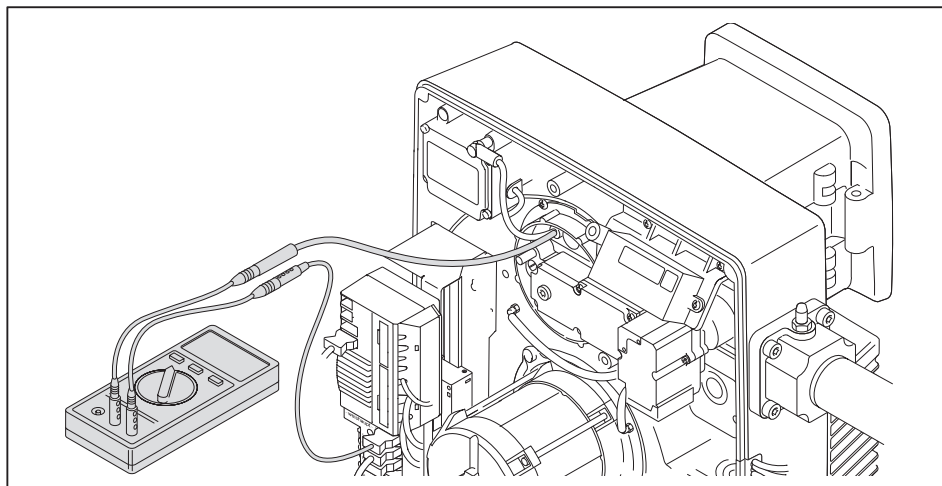

Pressure measuring device for mixing pressure

- ▶ Open pressure test point for mixing pressure ① and connect pressure measuring device.

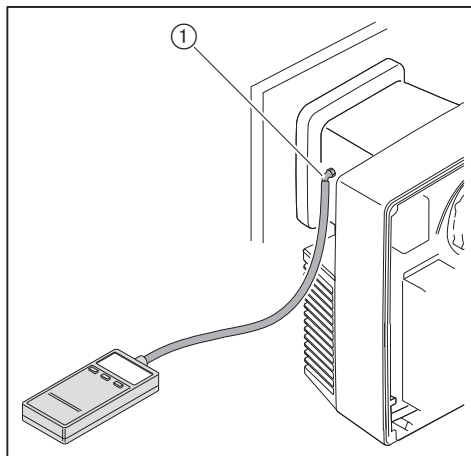

7.1.2 Check gas connection pressure

Minimum connection pressure



Add the combustion chamber pressure in mbar to the minimum connection pressure. The connection pressure should not fall below 15 mbar.

- ▶ Determine minimum connection pressure for low pressure installations from table [ch. 7.1.5].

Maximum connection pressure

Maximum connection pressure into isolating valve is 300 mbar.

Check connection pressure



Risk of explosion due to excess gas supply pressure

Exceeding the maximum connection pressure (see name plate) can damage the gas valve train and lead to an explosion.

Max. connection pressure see name plate.

- ▶ Check gas connection pressure



Only in conjunction with W-MF and gas connection pressure > 150 mbar

The pressure measuring device must be connected to the pressure regulator.

- ▶ Check gas connection pressure, see additional sheet (print No. 835109xx).

- ▶ Connect pressure measuring device to test point ①.
- ▶ Slowly open isolating valve whilst observing the pressure increase.

If the connection pressure exceeds the max. connection pressure:

- ▶ Immediately close isolating valve.
- ▶ Do not start plant.
- ▶ Notify system operator.

If the connection pressure does not maintain the min. connection pressure:

- ▶ Do not start plant.
- ▶ Notify system operator.

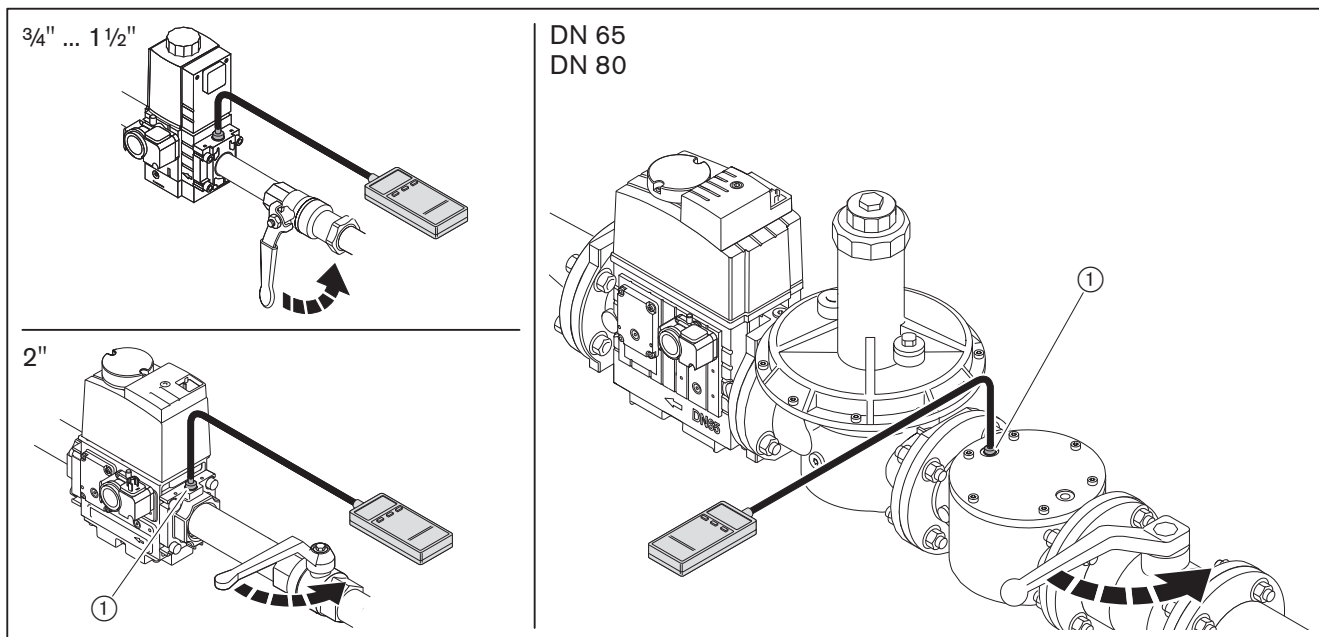

7 Commissioning

7.1.3 Check soundness of gas valve train

Carry out soundness test:

- prior to commissioning,
- after all service and maintenance work.

	First test phase	Second and third test phase
Test pressure	100 mbar ±10 %	100 mbar ±10 %
Waiting time for pressure equalisation	5 minutes	5 minutes
Test time	5 minutes	5 minutes
Permissible pressure loss	1 mbar	5 mbar (3/4" ... 2")
		1 mbar (DN 65 ... 150)

First test phase



Only in conjunction with W-MF and gas connection pressure > 150 mbar

In the first test phase, the testing device must be connected to the pressure regulator.

- ▶ Check soundness of gas valve train, see additional sheet (print No. 835109xx).

In the first phase the valve train section from the gas isolating valve up to the first valve of the multifunction assembly is tested.

- ▶ Switch off burner.
- ▶ Close gas isolating valve.
- ▶ Connect test equipment.
- ▶ Open test point between valve 1 and valve 2.
- ▶ Carry out test to table.

Second test phase

In the second phase the interspace in the multifunction assembly is tested.

- ▶ Connect test equipment.
- ▶ Carry out test to table.

Third test phase

In the third phase the valve train section from the multifunction assembly up to the gas butterfly valve is tested.

- ▶ Remove mixing head [ch. 9.3].
- ▶ Fit blanking plate ④.
- ▶ Fit mixing head.
- ▶ Connect test equipment.
- ▶ Carry out test to table.
- ▶ Close all test points.
- ▶ Remove blanking plate.

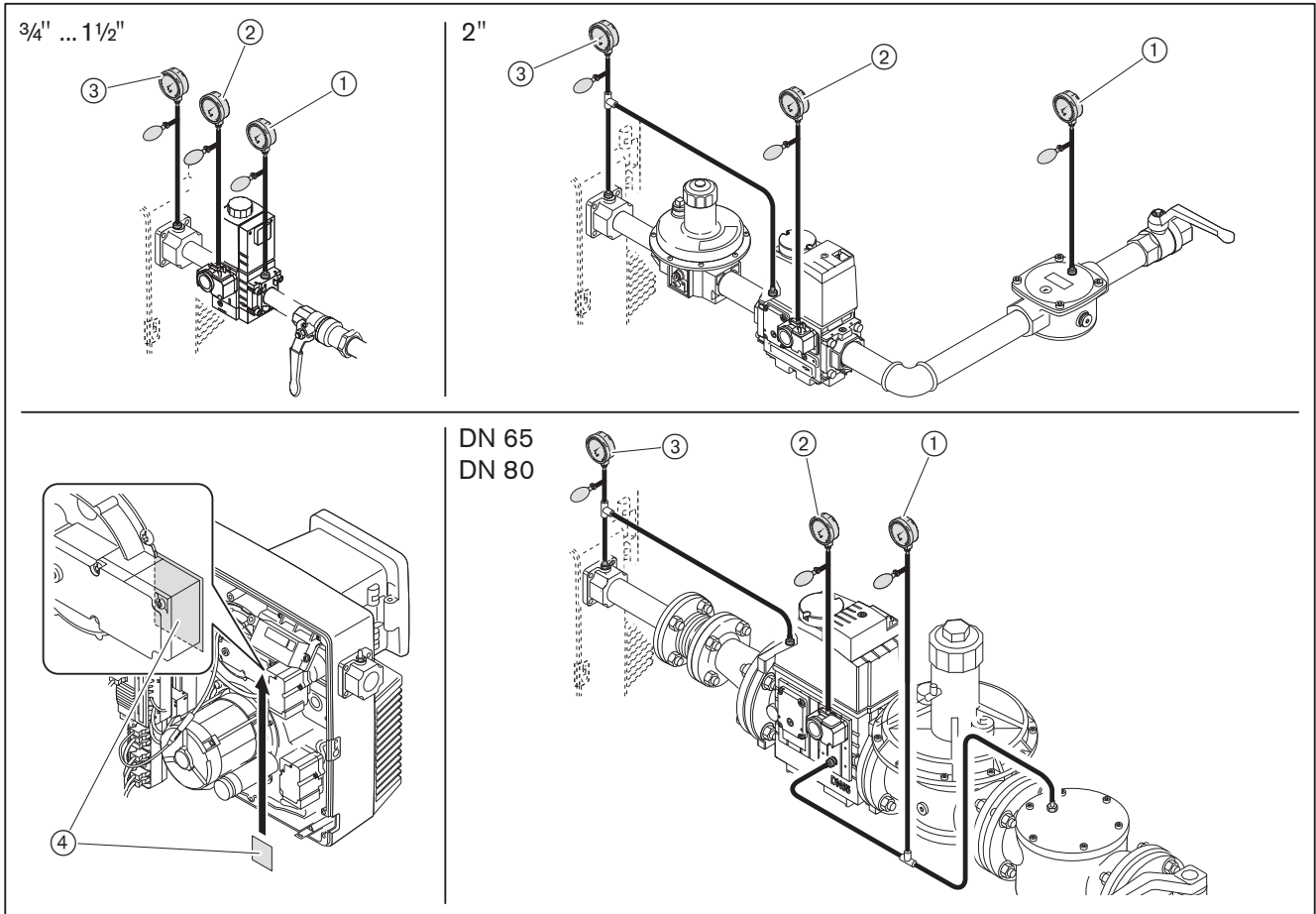

- ① First test phase
- ② Second test phase
- ③ Third test phase
- ④ Blanking plate

7 Commissioning

Fourth test phase

In the fourth test phase, the joint to the mixing head ① is tested for soundness. The test phase can only be carried out during or after burner commissioning. A leak detecting spray or electronic gas detector should be used for testing.

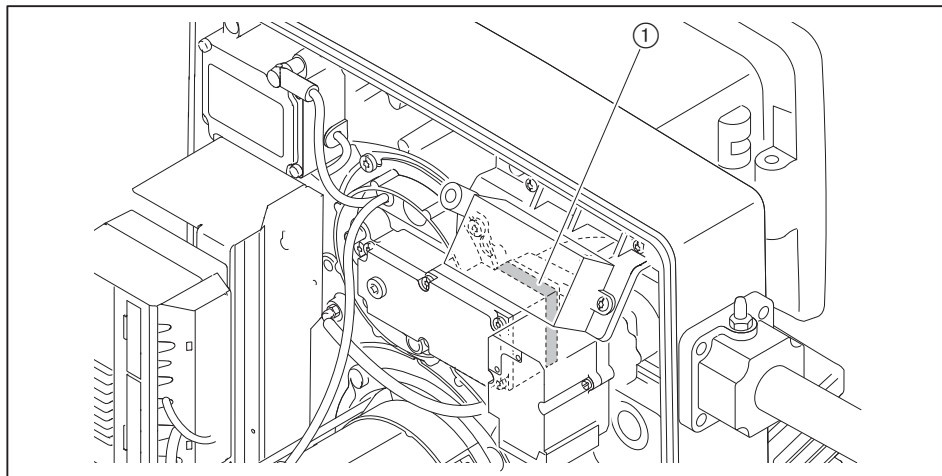

Use only leak detecting foam solutions, which do not cause corrosion, see DVGW-TRGI, worksheet G 600.

- ▶ Check all components, intersections and test points of the gas valve train between multifunction assembly and burner.
- ▶ Document result of the soundness test on the engineers report.

Test points

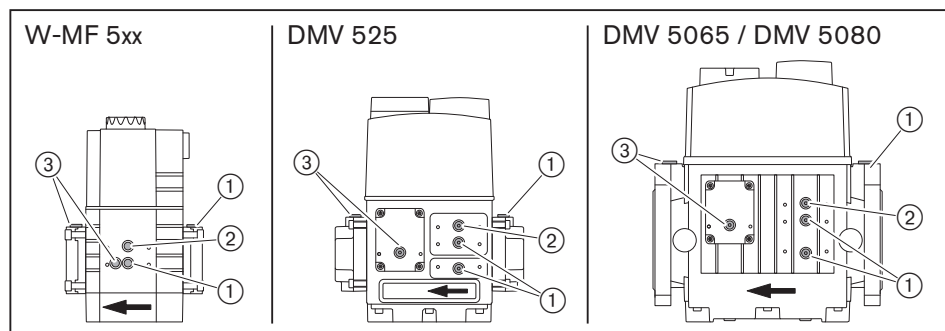

- ① Pressure into valve 1
- ② Pressure between valve 1 and valve 2
- ③ Pressure after valve 2

7.1.4 Purging the gas valve train

- ▶ Open test point into valve 1 [ch. 7.1.3].
- ▶ Connect an approved vent hose to the test point.
- ▶ Vent hose must lead to atmosphere.
- ▶ Slowly open gas isolating valve.
- ✓ The gas/air mixture in the valve train vents via the hose to safe atmosphere.
- ▶ Close gas isolating valve.
- ▶ Remove vent hose and immediately close test point.
- ▶ Use a test burner to ensure no air is present in the valve train.

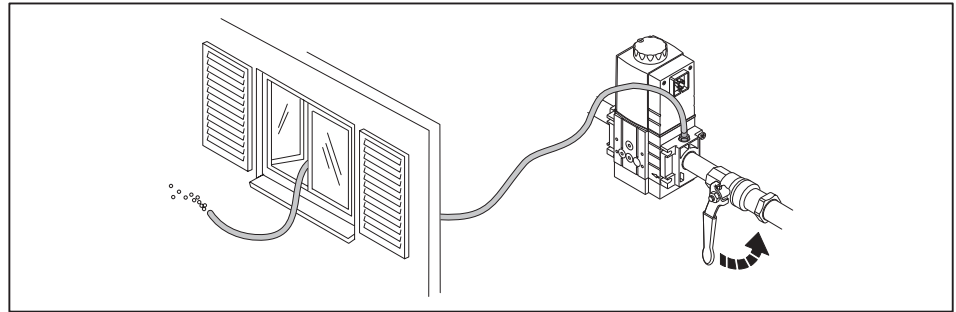

7.1.5 Preset pressure regulator

Determine setting pressure



Add the combustion chamber pressure in mbar to the setting pressure into the gas butterfly valve.

► Determine setting pressure from the table and note down.

The details given for calorific value H_i relate to 0 °C and 1013 mbar.

The table values have been calculated under ideal conditions. The values are therefore guide values for basic settings.

Full load [kW]	Setting pressure into gas butterfly valve [mbar]	Min. connection pressure into isolating valve [mbar] (low pressure supply)						
		Nominal diameter valve train	¾"	1"	1½"	2"	DN 65	DN 80
			W-MF 507	W-MF 512	W-MF 512	DMV 525	DMV 5065	DMV 5080
Natural Gas E: $H_i = 10.35 \text{ kWh/m}^3$, $d = 0.606$								
240	9.0		19	14	12	11	11	11
270	9.1		22	14	12	12	11	11
300	9.2		25	15	13	12	11	11
350	9.3		30	17	13	13	12	11
400	9.4		36	19	14	13	12	11
450	9.5		42	22	15	13	12	11
500	11.7		52	27	18	16	14	14
550	13.0		61	31	21	18	16	15
Natural Gas LL: $H_i = 8.83 \text{ kWh/m}^3$, $d = 0.641$								
240	11.3		26	17	15	14	13	13
270	11.2		29	18	15	14	13	13
300	10.9		33	19	15	14	13	13
350	10.7		40	22	16	15	13	13
360	10.7		41	22	16	14	13	13
400	11.7		49	26	18	16	14	14
450	13.0		60	30	21	18	16	15
500	14.3		72	35	23	20	17	17
550	16.8		86	42	27	23	20	19
Liquid Petroleum Gas: $H_i = 25.89 \text{ kWh/m}^3$, $d = 1.555$ The selection is calculated for Propane, it can however, also be used for Butane.								
240	6.3		13	11	-	-	-	-
270	6.9		14	11	-	-	-	-
300	7.3		16	12	-	-	-	-
350	8.1		19	14	-	-	-	-
400	8.9		22	15	-	-	-	-
450	9.7		26	17	-	-	-	-
500	10.5		29	19	-	-	-	-
550	11.3		33	21	-	-	-	-

Preset setting pressure



Only in conjunction with W-MF and gas connection pressure > 150 mbar

The pre-pressure must be set to approx. 90 mbar.

- ▶ Set FRS pressure regulator, see additional sheet (print No. 835109xx).

- ▶ Preset setting pressure determined at multifunction assembly.

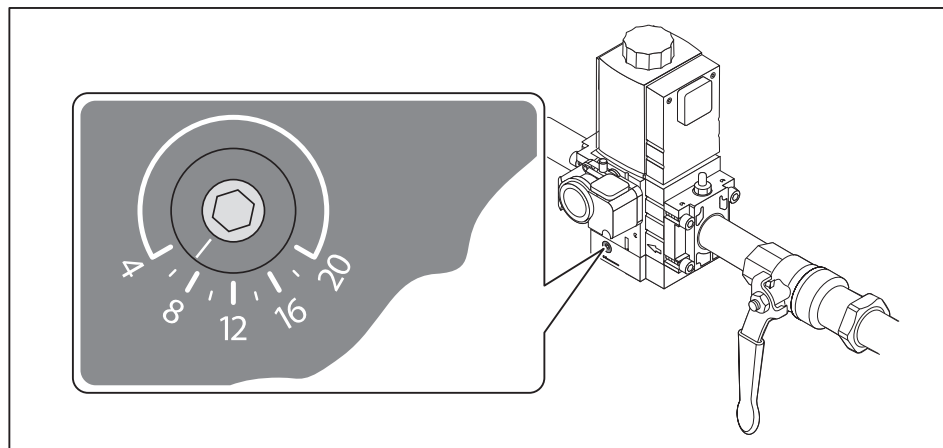

De-energise pressure regulator (2" ... DN 80)

- ▶ Remove closing cap ① and de-energise spring ②.

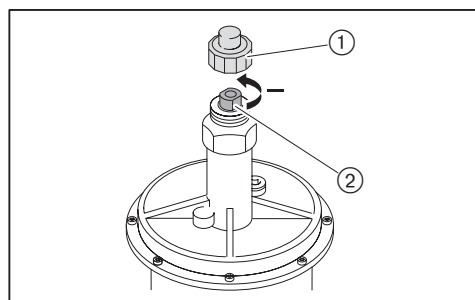

7 Commissioning

7.1.6 Setting values

Set mixing head relative to the combustion heat rating required. For this, the diffuser setting and the air damper setting should be matched.

Determine diffuser setting and air damper setting



Do not operate the burner outside of the capacity graph.

► Determine the diffuser setting (dimension X) and air damper setting required from the diagram and note down.

Example

	Example 1	Example 2
Burner capacity required	285 kW	475 kW
Combustion chamber pressure	1.5 mbar	3.5 mbar
Diffuser setting (dimension X)	0 mm	10 mm
Air damper setting	42°	> 80°

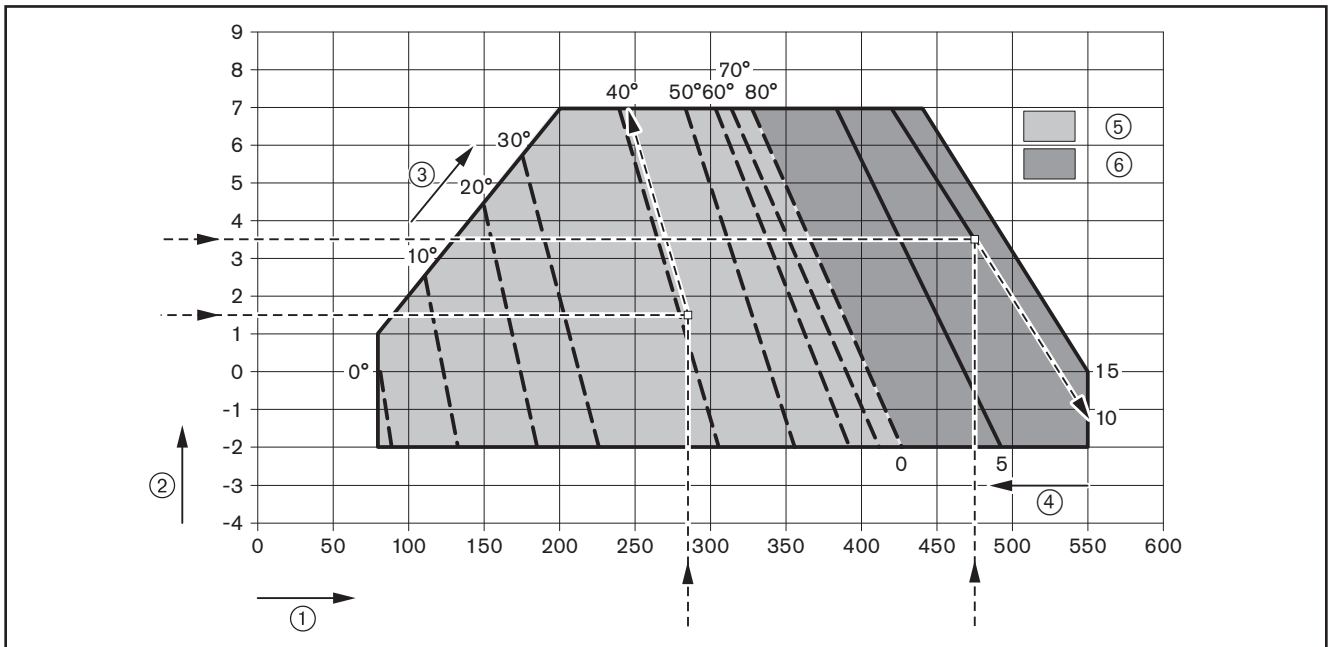

- ① Combustion heat rating [kW]
- ② Combustion chamber pressure [mbar]
- ③ Air damper setting
- ④ Diffuser setting [mm] (dimension X)
- ⑤ Air damper setting range with diffuser setting closed (X = 0 mm)
- ⑥ Setting range dimension X with air damper setting > 80°

Set diffuser

With dimension $X = 0$ mm the indicating bolt is flush with the cover of the nozzle assembly.

- Turn screw ①, until dimension X equals the value determined.

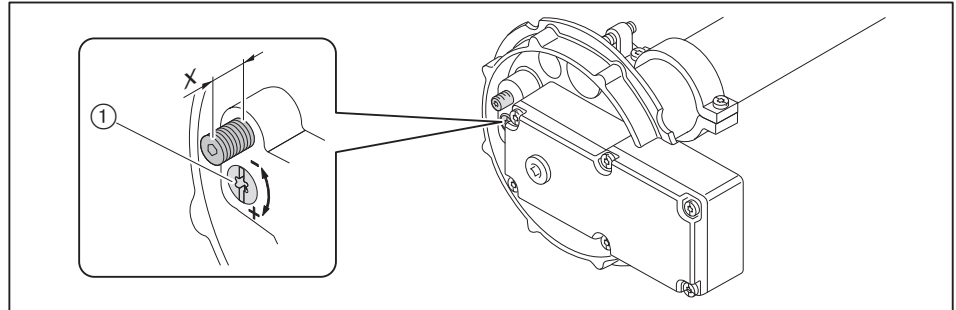

7.1.7 Preset gas and air pressure switch

The presetting of the pressure switches is only valid during commissioning. Once commissioning has been completed the pressure switches must be set correctly [ch. 7.3].

Air pressure switch without variable speed drive	approx. 6 mbar
with variable speed drive	approx. 1 mbar
Low gas pressure switch/valve proving gas pressure switch	12 mbar
High gas pressure switch (optional)	approx. twice control pressure

7.2 Adjusting the burner

7.2.1 Burner without variable speed drive



Risk of electric shock

Touching the ignition device can lead to electric shock.

- ▶ Do not touch ignition device during the ignition process.

- ▶ Check flame signal during commissioning [ch. 7.1.1].

1. Preset combustion manager

- ▶ Unplug bridging plug No. 7 on combustion manager.
- ▶ Switch on voltage supply.
- ✓ Combustion manager drives to Standby.



- ▶ Press [G] and [L/A] keys simultaneously.
- ✓ Combustion manager changes to access level.



- ▶ Press [+] key.
- ✓ Combustion manager changes into the setting level for step points.

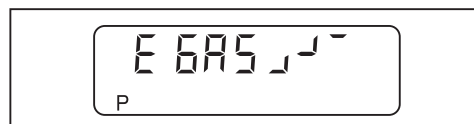

- ▶ Press [+] key.
- ✓ Factory setting operating point P9 (full load) is displayed.



- ▶ Press and hold [L/A] key and set air damper setting determined using the [-] or [+] key [ch. 7.1.6].
- ▶ Press and hold [G] key using [-] or [+] key set gas butterfly valve to the same value.
- ▶ Press [+] key.
- ✓ Factory setting operating point P1 (partial load) is displayed.



- ▶ Press [+] key to confirm factory setting.
- ✓ Factory setting operating point P0 (ignition position) is displayed.



- ▶ Press [+] key to confirm factory setting.
- ✓ Combustion manager is preset.

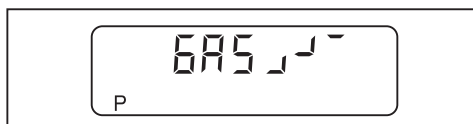

2. Check sequence of operation

- ▶ Open gas isolating valve.
- ✓ Pressure in gas valve train increases.
- ▶ Close isolating valve.
- ▶ Plug in bridging plug No. 7 on combustion manager.
- ✓ Burner starts.
- ✓ Valve proving is carried out.
- ▶ Check sequence of operation:
 - Valves open.
 - Gas pressure switch reacts.
 - Burner start is interrupted.
 - Burner does not detect a flame and goes to lockout.

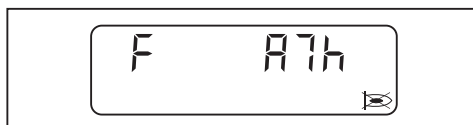

- ▶ Reset burner using the [ENTER] key.
- ✓ Combustion manager drives to Standby.



7 Commissioning

3. Preset setting pressure



If a controlled shutdown or lockout occurs during setting:

- ▶ Briefly press [G] and [L/A] keys simultaneously.
- ▶ Press [+] key.
- ✓ Combustion manager changes to setting level.

- ▶ Open test point for setting pressure and connect pressure measuring device.

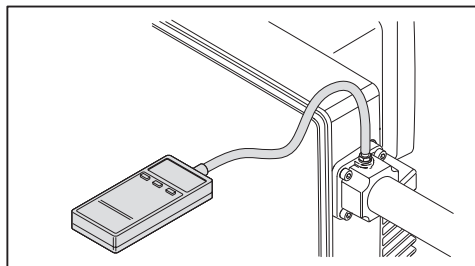

- ▶ Open gas isolating valve.
- ▶ Briefly press [-] and [+] keys simultaneously.
- ✓ The display shows E ACCESS.



- ▶ Press [+] key.

Burner starts according to the sequence of operation and stops at operating point P0 (ignition position).

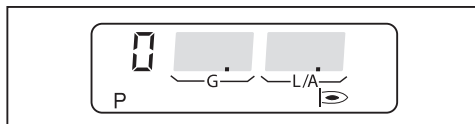

- ▶ Preset setting pressure determined at multifunction assembly [ch. 7.1.5].
- ▶ Check CO content of combustion and if necessary adjust combustion values via gas butterfly valve setting [G].

4. Drive to full load

- ▶ Press [+] key.
- ✓ Burner drives to operating point P1.

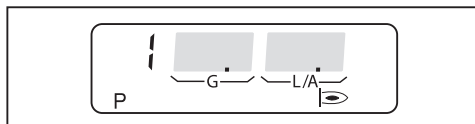

- ▶ Check CO content of combustion and if necessary adjust combustion values via gas butterfly valve setting [G].
- ▶ Press [+] key.
- ✓ Next operating point is initiated.
- ▶ Repeat steps at each operating point until P9 has been reached.



5. Adjust full load

When adjusting, the ratings data given by the boiler manufacturer and the capacity graph of the burner should be observed [ch. 3.4.6].

- ▶ Calculate gas throughput (operating volume V_B) required [ch. 7.6].
- ▶ Optimise setting pressure and/or gas butterfly valve setting [G] until gas throughput (V_B) has been reached.
- ▶ Check combustion values
- ▶ Determine combustion limit and set excess air via air damper setting [L/A], see [ch. 7.5].
- ▶ Determine gas throughput once more and adjust if necessary.
- ▶ Re-set excess air.



The setting pressure must not be altered once this work has been completed.

6. Adjusting operating point P1

- ▶ Press [-] key.
- ✓ P9 is saved.
- ✓ Burner drives to operating point P8.

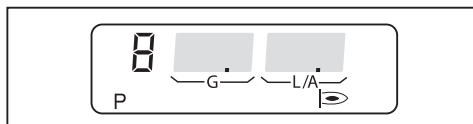

- ▶ Check CO content of combustion and if necessary adjust combustion values via gas butterfly valve setting [G].
- ▶ Press [-] key.
- ✓ Next operating point is initiated.
- ▶ Repeat steps at each operating point until P1 has been reached.



Operating point P1 must lie within the capacity graph [ch. 3.4.6].

- ▶ Determine gas throughput and if necessary adjust via gas butterfly valve setting [G].
- ▶ Check combustion values
- ▶ Determine combustion limit and set excess air of approx. 20 ... 25 % via air damper setting [L/A].

7 Commissioning

7. Adjust ignition load

- ▶ Press [-] key.
- ✓ Burner drives to operating point P0 (ignition position).

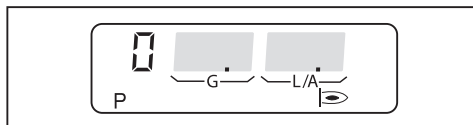

- ▶ Check combustion values in operating point P0 (ignition position).
- ▶ Set O₂ content of 4 ... 5 % above gas butterfly valve setting [G].
- ▶ Check mixing pressure

The mixing pressure in ignition position must be between 0.5 – 2.0 mbar.

- ▶ If necessary, adjust mixing pressure via air damper setting [L/A].

8. Perform linearisation [ch. 6.3]

- ▶ Press [+] key.
- ✓ Burner drives to operating point P1.

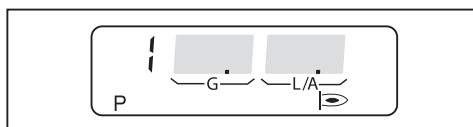

- ▶ Press [ENTER].
- ✓ Combustion manager changes to linearisation mode.

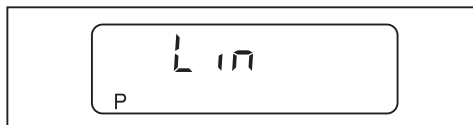

- ▶ Confirm with [+] key.
- ✓ Linearisation is initiated.
- ✓ The display then shows operating point P1.
- ✓ Calculation from P1 to P9 was carried out.

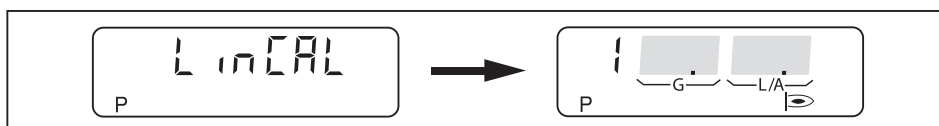

9. Optimising the operating points

- ▶ Check combustion values
- ▶ Press and hold [G] and optimise combustion values using [-] or [+] key.
- ▶ Press [+] key.
- ✓ Next operating point is initiated.
- ▶ Repeat steps at each operating point until P9 has been reached.



- ▶ Press [G] and [L/A] keys simultaneously.
- ✓ The upper operating limit (bo) is displayed.

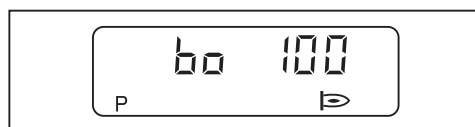

10. Adjust partial load

- ▶ Press [G] and [L/A] keys simultaneously.
- ✓ Burner drives to partial load.
- ✓ The lower operating limit is displayed (bu).

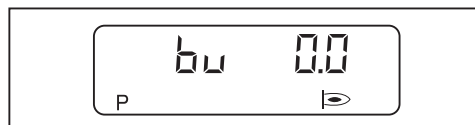

- ▶ Define partial load whilst observing:
 - data supplied by boiler manufacturer,
 - burner capacity graph [ch. 3.4.6].
- ▶ Determine gas throughput, if necessary adjust partial load (bu) using [+] key.
- ▶ Press [G] and [L/A] keys simultaneously.
- ✓ Combustion manager changes to operating level (10).
- ✓ Combustion manager is programmed.



11. Check start behaviour

- ▶ Switch off and restart burner.
- ▶ Check start behaviour and if necessary correct operating point P0 (ignition position).

If the ignition position has been altered:

- ▶ Re-check start behaviour.

7.2.2 Burner with variable speed drive (optional)



Risk of electric shock

Touching the ignition device can lead to electric shock.

- ▶ Do not touch ignition device during the ignition process.

- ▶ Check flame signal during commissioning [ch. 7.1.1].

1. Preset combustion manager

- ▶ Unplug bridging plug No. 7 on combustion manager.
- ▶ Switch on voltage supply.
- ✓ Combustion manager drives to Standby.



- ▶ Press [G] and [L/A] keys simultaneously.
- ✓ Combustion manager changes to access level.



- ▶ Press [+] key.
- ✓ Combustion manager changes into the setting level for step points.

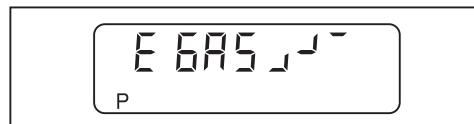

- ▶ Press [+] key.
- ✓ Factory setting operating point P9 (full load) is displayed.



- ▶ Press and hold [L/A] key and set air damper setting determined using the [-] or [+] key [ch. 7.1.6].
- ▶ Press and hold [G] key using [-] or [+] key set gas butterfly valve to the same value.
- ▶ Press [Enter] and [L/A] simultaneously.
- ✓ Factory setting fan speed (100 %) is displayed.

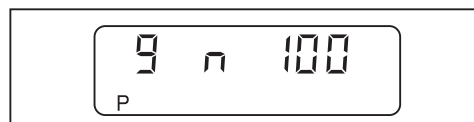

- ▶ Press [+] key.
- ✓ Factory setting operating point P1 (partial load) is displayed.



- ▶ Press [Enter] and [L/A] simultaneously.
- ✓ Factory setting fan speed (100 %) is displayed.

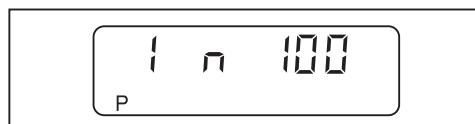

- ▶ Press [+] key to confirm factory setting.
- ✓ Factory setting operating point P0 (ignition position) is displayed.



- ▶ Press [Enter] and [L/A] simultaneously.
- ✓ Factory setting fan speed (70 %) is displayed.

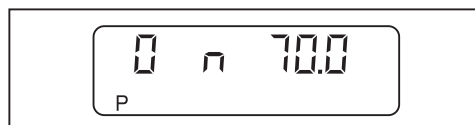

- ▶ Press [+] key to confirm factory setting.
- ✓ Combustion manager is preset.

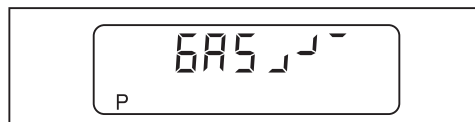

7 Commissioning

2. Check sequence of operation

- ▶ Open gas isolating valve.
- ✓ Pressure in gas valve train increases.
- ▶ Close isolating valve.
- ▶ Plug in bridging plug No. 7 on combustion manager.
- ✓ Burner starts.
- ✓ Valve proving is carried out.

Speed standardisation starts.



- ▶ Press [+] key within 20 seconds.
- ✓ Speed standardisation is carried out.
- ✓ U and the current fan speed are displayed.



- ▶ Wait approx. 5 seconds, until the fan speed has stabilised.
- ▶ Press [+] key within 15 seconds.
- ✓ Speed standardisation is complete.
- ▶ Check sequence of operation:
 - Valves open.
 - Gas pressure switch reacts.
 - Burner start is interrupted.
 - Burner does not detect a flame and goes to lockout.

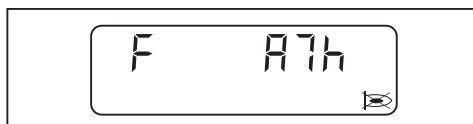

- ▶ Reset burner using the [ENTER] key.
- ✓ Combustion manager drives to Standby.



3. Preset setting pressure



If a controlled shutdown or lockout occurs during setting:

- ▶ Briefly press [G] and [L/A] keys simultaneously.
- ▶ Press [+] key.
- ✓ Combustion manager changes to setting level.

- ▶ Open test point for setting pressure and connect pressure measuring device.

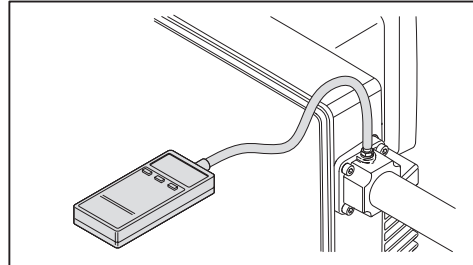

- ▶ Open gas isolating valve.
- ▶ Briefly press [-] and [+] keys simultaneously.
- ✓ The display shows E ACCESS.



- ▶ Press [+] key.

Burner starts according to the sequence of operation and stops at operating point P0 (ignition position).

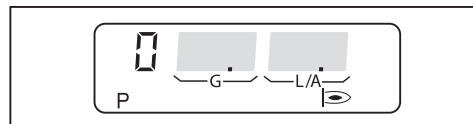

- ▶ Preset setting pressure determined at multifunction assembly [ch. 7.1.5].
- ▶ Check CO content of combustion and if necessary adjust combustion values via gas butterfly valve setting [G].

7 Commissioning

4. Drive to full load

- ▶ Press [+] key.
- ✓ Burner drives to operating point P1.

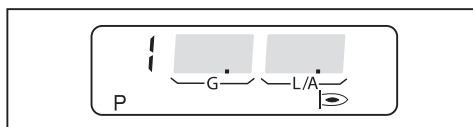

- ▶ Check CO content of combustion and if necessary adjust combustion values via gas butterfly valve setting [G].
- ▶ Press [+] key.
- ✓ Next operating point is initiated.
- ▶ Repeat steps at each operating point until P9 has been reached.



5. Adjust full load

When adjusting, the ratings data given by the boiler manufacturer and the capacity graph of the burner should be observed [ch. 3.4.6].



Select speed at full load as low as possible, but not less than 80 %. Observe flame stability.

- ▶ Calculate gas throughput (operating volume V_B) required [ch. 7.6].
- ▶ Optimise setting pressure and/or gas butterfly valve setting [G] until gas throughput (V_B) has been reached.
- ▶ Check combustion values
- ▶ Determine combustion limit, set excess air via air damper setting and speed.
- ▶ Determine gas throughput once more and adjust if necessary.
- ▶ Re-set excess air.



The setting pressure must not be altered once this work has been completed.

6. Adjusting operating point P1

- ▶ Press [-] key.
- ✓ P9 is saved.
- ✓ Burner drives to operating point P8.

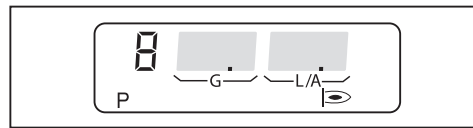

- ▶ Check CO content of combustion and if necessary adjust combustion values via gas butterfly valve setting [G].
- ▶ Press [-] key.
- ✓ Next operating point is initiated.
- ▶ Repeat steps at each operating point until P1 has been reached.



The speed at operating point P1 must not be less than 30 %.
Recommended speed: 50 %.

A minimum speed of 50 % should be aimed for in operating point P1 whilst observing combustion values and flame stability.

- ▶ Slowly reduce speed using [L/A] and [ENTER] key, whilst opening air damper setting alternately using the [L/A] key.

Operating point P1 must lie within the capacity graph [ch. 3.4.6].

- ▶ Determine gas throughput and if necessary adjust via gas butterfly valve setting [G].
- ▶ Check combustion values
- ▶ Determine combustion limit and set excess air of approx. 20 ... 25 % via air damper setting [L/A].

7. Adjust ignition load

The ignition speed must not be less than 70 %.

- ▶ Press [-] key.
- ✓ Burner drives to operating point P0 (ignition position).

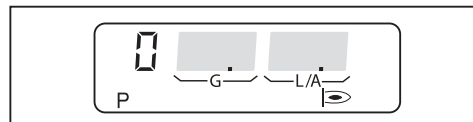

- ▶ Check combustion values in operating point P0 (ignition position).
- ▶ Set O₂ content of 4 ... 5 % above gas butterfly valve setting [G].
- ▶ Check mixing pressure

The mixing pressure in ignition position must be between 0.5 2.0 mbar.

- ▶ If necessary, adjust mixing pressure via air damper setting [L/A].

7 Commissioning

8. Perform linearisation [ch. 6.3]

- ▶ Press [+] key.
- ✓ Burner drives to operating point P1.

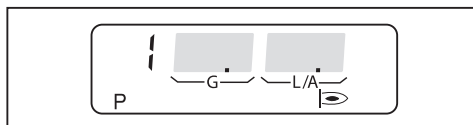

- ▶ Press [ENTER].
- ✓ Combustion manager changes to linearisation mode.

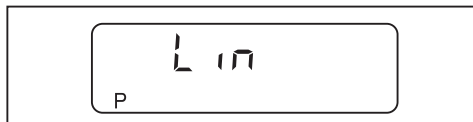

- ▶ Confirm with [+] key.
- ✓ Linearisation is initiated.
- ✓ The display then shows operating point P1.
- ✓ Calculation from P1 to P9 was carried out.

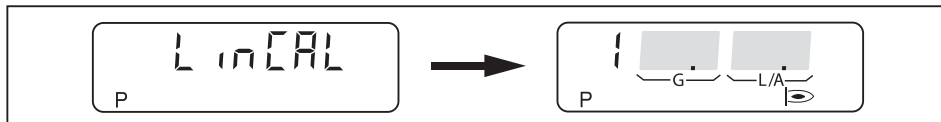

9. Optimising the operating points

- ▶ Check combustion values
- ▶ Press and hold [G] and optimise combustion values using [-] or [+] key.
- ▶ Press [+] key.
- ✓ Next operating point is initiated.
- ▶ Repeat steps at each operating point until P9 has been reached.



- ▶ Press [G] and [L/A] keys simultaneously.
- ✓ The upper operating limit (bo) is displayed.

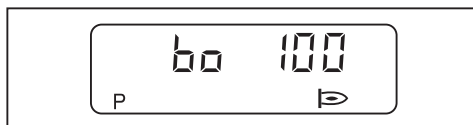

10. Adjust partial load

- ▶ Press [G] and [L/A] keys simultaneously.
- ✓ Burner drives to partial load.
- ✓ The lower operating limit is displayed (bu).

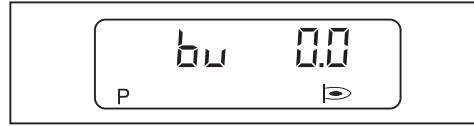

- ▶ Define partial load whilst observing:
 - data supplied by boiler manufacturer,
 - burner capacity graph [ch. 3.4.6].
- ▶ Determine gas throughput, if necessary adjust partial load (bu) using [+] key.
- ▶ Press [G] and [L/A] keys simultaneously.
- ✓ Combustion manager changes to operating level (10).
- ✓ Combustion manager is programmed.



11. Check start behaviour

- ▶ Switch off and restart burner.
- ▶ Check start behaviour and if necessary correct operating point P0 (ignition position).

If the ignition position has been altered:

- ▶ Re-check start behaviour.

7.3 Set pressure switches

7.3.1 Set gas pressure switch

Low gas pressure switch/valve proving gas pressure switch

The switch point must be checked and if necessary adjusted during commissioning.

- ▶ Connect pressure measuring device to test point ① of the low gas pressure switch.
- ▶ Start burner and drive to full load.
- ▶ Slowly close gas isolating valve until either:
 - the O₂ content in the flue gas increases to above 7 %,
 - the flame stability considerably worsens,
 - the CO content increases,
 - the gas pressure reaches 12 mbar,
 - or the gas flow pressure drops to 50 %.
- ▶ Determine gas pressure.
- ▶ Slowly open gas isolating valve.
- ▶ Set the pressure determined as switch point at the setting cam ②, minimum value 12 mbar.

Check switch point

- ▶ Restart the burner.
- ▶ Slowly close gas isolating valve.
- ✓ If the low gas program starts, the gas pressure switch has been set correctly.
- ✓ If a lockout occurs or if the combustion reaches a critical condition, the low gas pressure switch reacts too late.

If lockout occurs:

- ▶ Increase switch point at setting cam ②.
- ▶ Slowly open gas isolating valve.
- ▶ Re-check switch point.

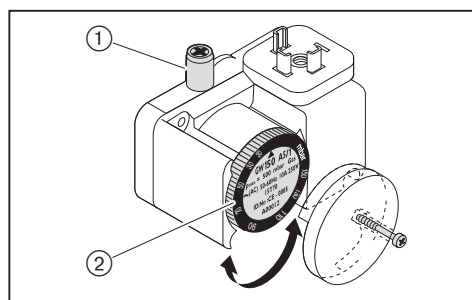

Set (optional) high gas pressure switch

Depending on the burner application, optional equipment may be required for optimum operation [ch. 12.1].

- ▶ Set high gas pressure switch to $1.3 \times P_{\text{Gas full load}}$ (flow pressure at full load).

7.3.2 Set air pressure switch

The switch point must be checked and if necessary adjusted during commissioning.

- ▶ Connect pressure measuring device for differential pressure measurement.
- ▶ Start the burner.
- ▶ Carry out differential pressure measurement across the whole capacity range of the burner and determine the lowest differential pressure.
- ▶ Calculate switch point (80 % of release pressure or lowest differential pressure).
- ▶ Set the switch point determined at the setting cam ①.

Example

Lowest differential pressure	7.5 mbar
Switch point air pressure switch (80 %)	$7.5 \text{ mbar} \times 0.8 = 6.0 \text{ mbar}$

Site specific influences on the air pressure, (e.g. by the flue gas system, heat exchanger, installation location or air supply) may make it necessary to vary the setting of the air pressure switch.

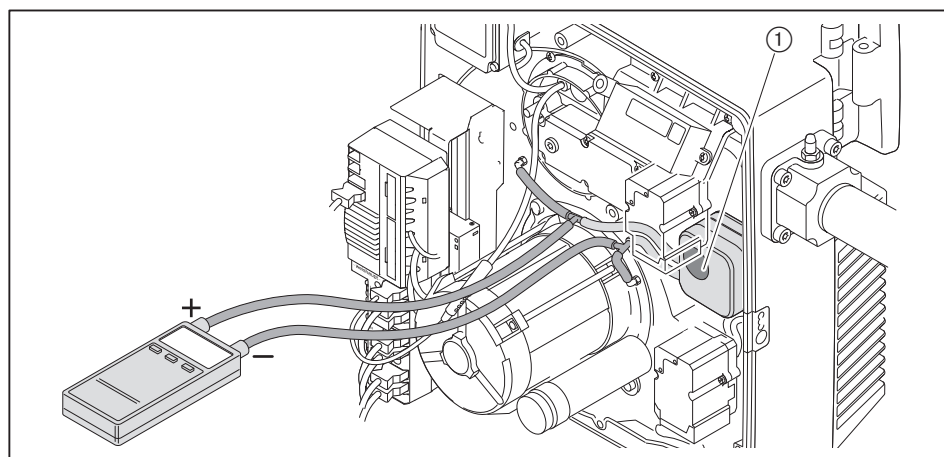

7.4 Concluding work

- ▶ Check control and safety devices.
- ▶ Remove gas pressure measuring devices and close all test points.
- ▶ Conclude valve proving of gas valve train (fourth test phase) [ch. 7.1.3].
- ▶ Enter combustion values and settings in the commissioning record and/or test sheet.
- ▶ Enter setting values on the sticker ① supplied.
- ▶ Adhere sticker to the burner.
- ▶ Mount cover on burner.
- ▶ Inform the operator about the use of the equipment.
- ▶ Hand the installation and operating manual to the operator and inform him that this should be kept with the appliance.
- ▶ Point out to operator that the installation should be serviced annually.

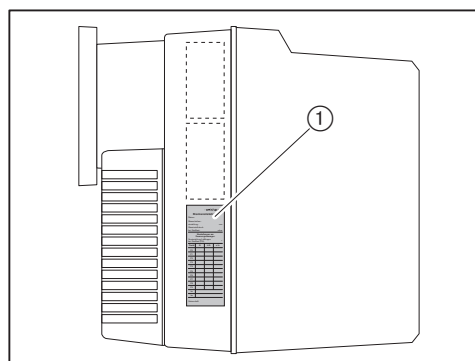

7.5 Check combustion

Determine excess air

- ▶ Slowly close air damper(s) in the relevant operating point, until the combustion limit is reached (CO content approx. 100 ppm).
- ▶ Measure and document O₂ content.
- ▶ Read air number (λ).

Increase air number to ensure sufficient excess air:

- by 0.15 ... 0.2 (equates to 15 ... 20 % excess air),
- by more than 0.2 for more difficult conditions, such as:
 - dirty combustion air,
 - fluctuating intake temperature,
 - fluctuating chimney draught.

Example

$$\lambda + 0.15 = \lambda^*$$

- ▶ Set air number (λ*), do not exceed CO content of 50 ppm.
- ▶ Measure and document O₂ content.

Check flue gas temperature

- ▶ Check flue gas temperature.
- ▶ Ensure that the flue gas temperature complies with the data provided by the boiler manufacturer.
- ▶ If necessary adjust flue gas temperature, e.g.:
 - Increase burner capacity in partial load to avoid condensation in the flue gas ducts, except on condensing units.
 - Reduce burner capacity in full load to improve efficiency.
 - Adjust heat exchanger to the data provided by the manufacturer.

Determine flue gas losses

- ▶ Drive to full load.
- ▶ Measure combustion air temperature (t_L) near the air damper(s).
- ▶ Measure oxygen content (O₂) and flue gas temperature (t_A) at the same time at one point.
- ▶ Determine flue gas losses using the following formula:

$$q_A = (t_A - t_L) \cdot \left(\frac{A_2}{21 - O_2} \right) + B$$

q_A Flue gas losses [%]

t_A Flue gas temperature [°C]

t_L Combustion air temperature [°C]

O₂ Volumetric content of oxygen in dry flue gas [%]

Fuel factors	Natural Gas	Liquid Petroleum Gas
A2	0.66	0.63
B	0.009	0.008

7.6 Calculate gas throughput

Formula symbol	Explanation	Example values
V_B	Operating volume [m ³ /h] Volume measured at gas meter at current pressure and temperature (gas throughput).	–
V_N	Standard volume [m ³ /h] Volume gained by gas at 1013 mbar and 0 °C.	–
f	Conversion factor	–
Q_N	Heat rating [kW]	500 kW
η	Boiler efficiency (e. g. 92 % \pm 0.92)	0.92
H_i	Calorific value [kWh/m ³] at 0 °C and 1013 mbar	10.35 kW/m ³ (Natural Gas E)
t_{Gas}	Gas temperature at gas meter [°C]	10 °C
P_{Gas}	Pressure at gas meter [mbar]	30 mbar
P_{Baro}	Barometric air pressure [mbar], see table	500 m \pm 955 mbar
V_G	Gas throughput determined at gas meter	1.85 m ³
T_M	Measuring time [seconds]	120 seconds

Calculate normal volume

- ▶ Calculate the normal volume (V_N) using the following formula.

$$V_N = \frac{Q_N}{\eta \cdot H_i} \quad V_N = \frac{500 \text{ kW}}{0.92 \cdot 10.35 \text{ kW/m}^3} = 52.5 \text{ m}^3/\text{h}$$

Calculate conversion factor

- ▶ Determine gas temperature (t_{Gas}) and pressure (P_{Gas}) at gas meter.
- ▶ Determine barometric air pressure (P_{Baro}) from table.

Height above sea level [m]	0	100	200	300	400	500	600	700	800	900	1000	1100	1200	1300
P_{Baro} [mbar]	1013	1001	990	978	966	955	943	932	921	910	899	888	877	866

- ▶ Calculate conversion factor (f) using the following formula.

$$f = \frac{P_{Baro} + P_{Gas}}{1013} \cdot \frac{273}{273 + t_{Gas}} \quad f = \frac{955 + 30}{1013} \cdot \frac{273}{273 + 10} = 0.938$$

Calculate operating volume (gas throughput) required

$$V_B = \frac{V_N}{f} \quad V_B = \frac{52.5 \text{ m}^3/\text{h}}{0.938} = 56.0 \text{ m}^3/\text{h}$$

Determine current operating volume (gas throughput)

- ▶ Measure gas throughput (V_G) at gas meter, measuring time (T_M) should be a minimum of 60 seconds.
- ▶ Calculate operating volume (V_B) using the following formula.

$$V_B = \frac{3600 \cdot V_G}{T_M} \quad V_B = \frac{3600 \cdot 1.85 \text{ m}^3}{120 \text{ s}} = 55.5 \text{ m}^3/\text{h}$$

7 Commissioning

7.7 Subsequent optimisation of operating points

If necessary, the combustion values can subsequently be corrected.

- ▶ Unplug bridging plug No. 7 on combustion manager.
- ✓ Combustion manager drives to Standby.

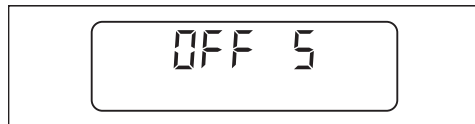

- ▶ Briefly press [-] and [+] simultaneously.
- ✓ Combustion manager changes to access level.



- ▶ Press [+].
- ✓ Combustion manager changes to setting level.



- ▶ Plug in bridging plug No. 7 on combustion manager.
- ✓ Burner starts and stops in operating point P0 (ignition position).
- ▶ Initiate the other operating points using the [+] or [-] key and optimise if required.

Exit setting level

- ▶ Press [G] and [L/A] simultaneously.
- ✓ The upper operating limit (bo) is displayed.
- ▶ Press [G] and [L/A] simultaneously.
- ✓ The lower operating limit is displayed (bu).
- ▶ Press [G] and [L/A] simultaneously.
- ✓ The combustion manager changes to operating level.

8 Shutdown

For breaks in operation:

- ▶ Switch off burner.
- ▶ Close fuel shut off devices.

9 Servicing

9.1 Notes on servicing



Risk of explosion due to leaking gas

Improper service work can lead to escaping gas and explosion.

- ▶ Close fuel shut off devices prior to starting work.
- ▶ Care should be taken when dismantling and assembling gas carrying components.
- ▶ Close the screws on the test points ensuring the tests points are sealed.



Risk of electric shock

Working on the device when voltage is applied can lead to electric shock.

- ▶ Isolate the device from the power supply prior to starting any work.
- ▶ Safeguard against accidental restart.



Electric shock caused by frequency converter

It is possible that electrical components continue to carry voltage and cause electric shock even after the voltage supply has been disconnected.

- ▶ Wait approx. 5 minutes before commencing work.
- ✓ Electric voltage has dissipated.



Danger of getting burned on hot components

Hot components can lead to burns.

- ▶ Allow components to cool.

Servicing must only be carried out by qualified personnel. The combustion plant should be serviced annually. Depending on site conditions more frequent checks may be required.

Components, which show increased wear and tear or whose design lifespan is or will be exceeded prior to the next service should be replaced as a precaution.

The design lifespan of the components is listed in the service plan [ch. 9.2].



Weishaupt recommends a service contract is entered into to ensure regular inspections.

The following components must only be replaced and must not be repaired:

- combustion manager
- flame sensor
- actuator
- multifunction assembly / double gas valve,
- pressure regulator
- pressure switch

Prior to every servicing

- ▶ Inform the operator about the extent of service work to be carried out.
- ▶ Switch off mains switch of installation and safeguard against accidental reactivation.
- ▶ Close fuel shut off devices.
- ▶ Remove cover.
- ▶ Unplug boiler control connection plug from combustion manager.

Following servicing



Risk of electric shock

Touching the ignition device can lead to electric shock.

- ▶ Do not touch ignition device during the ignition process.

-
- ▶ Check tightness of gas carrying components.
 - ▶ Check function of:
 - ignition,
 - flame monitoring,
 - gas carrying components (gas connection pressure and setting pressure),
 - pressure switch,
 - control and safety devices.
 - ▶ Check combustion values, if necessary re-adjust the burner.
 - ▶ Enter combustion values and settings in the commissioning record.
 - ▶ Enter setting values on the sticker supplied.
 - ▶ Adhere sticker to the burner.
 - ▶ Refit cover.

9 Servicing

9.2 Service plan

Components	Criteria / design lifespan ⁽¹⁾	Service procedure
Fan wheel	Soiling	► Clean
	Damage	► Replace
Air duct	Soiling	► Clean
Air damper	Soiling	► Clean
Air pressure switch	Switch point	► Check
	250 000 burner starts or 10 years ⁽²⁾	► Replace
Ignition cable	Damage	► Replace
Ignition electrode	Soiling	► Clean
	Damage/wear	► Replace
Combustion Manager	250 000 burner starts or 10 years ⁽²⁾	► Replacement recommended
Ionisation cable	Damage	► Replace
Ionisation electrode	Soiling	► Clean
	Damage/wear	► Replace Recommendation: at least every 2 years
Flame tube/diffuser	Soiling	► Clean
	Damage	► Replace
Double gas valve, multifunction assembly with valve testing system (valve proving)	Fault identified	► Replace
Double gas valve, multifunction assembly without valve testing system (valve proving)	Function / soundness less than DN 25: 200 000 burner starts or 10 years ⁽²⁾ DN 25 to DN 65: 100 000 burner starts or 10 years ⁽²⁾ DN 80 50 000 burner starts or 10 years ⁽²⁾	► Replace
Breather plug multifunction assembly	Soiling	► Replace
Filter insert multifunction assembly, gas filter	Soiling	► Replace
Gas pressure regulator	Setting pressure	► Check
	Function / soundness	► Replace
	15 years	► Replace
Gas pressure switch	Switch point	► Check
	50 000 burner starts or 10 years ⁽²⁾	► Replace

⁽¹⁾ The specified design lifespan applies for typical use in heating, hot water and steam systems as well as for thermal process systems to EN 746.

⁽²⁾ If a criterion is reached, carry out maintenance measures.

9.3 Removing and refitting mixing head

Observe notes on servicing [ch. 9.1].



Risk of explosion due to leaking gas

It is possible for gas to leak out if the gasket ③ is seated incorrectly.

- ▶ Following work on the mixing head, ensure the gasket is clean and seated correctly, if necessary replace.
- ▶ Check for leaks, see Fourth test phase [ch. 7.1.3].

Removing

- ▶ Unplug ionisation cable ⑤.
- ▶ Unplug ignition cable ①.
- ▶ Undo screws ④.
- ▶ Turn mixing head ② to the left up to the recess and remove.

Refitting

- ▶ Refit mixing head in reverse order ensuring correct alignment and cleanliness of gasket ③.

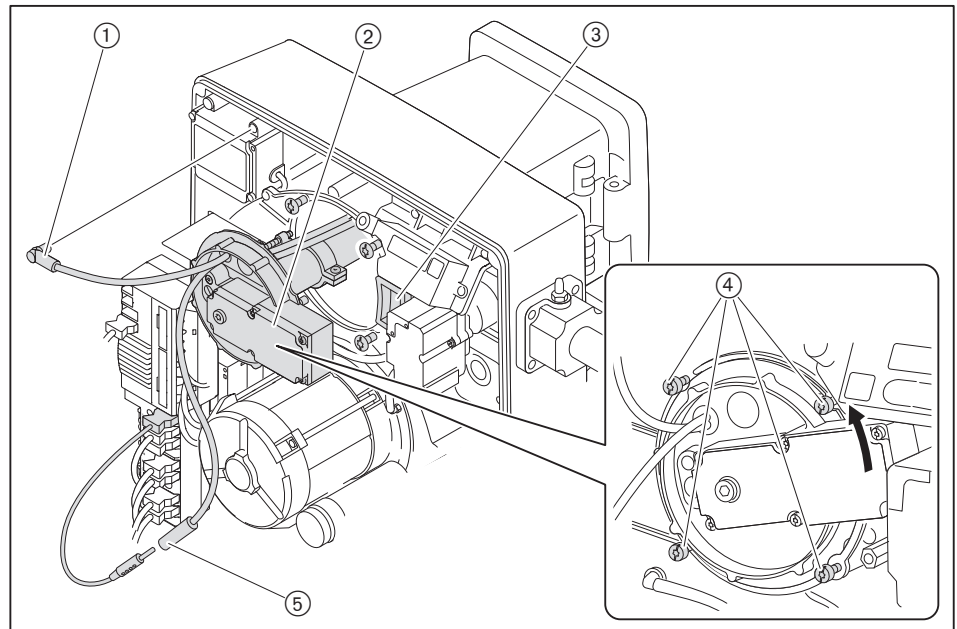

9 Servicing

9.4 Set mixing head

Observe notes on servicing [ch. 9.1].

The distance between diffuser and flame tube front edge S1 can not be measured with the burner mounted. This is only possible indirectly with the mixing head removed, with dimension Lx.



Dimension Lx changes according to the combustion head extension used.

- ▶ Remove mixing head [ch. 9.3].
- ▶ Turn setting screw ① until the indicating bolt ⑤ is flush with the nozzle assembly cover (dimension X = 0 mm).
- ▶ Check dimension Lx.

If the value measured deviates from dimension Lx:

- ▶ Undo screws ②.
- ▶ Adjust flame tube ③ until dimension Lx has been reached.
- ▶ Re-tighten screws ②.

If the screws ② have been loosened:

- ▶ Check position of electrodes and gas orifices ④.

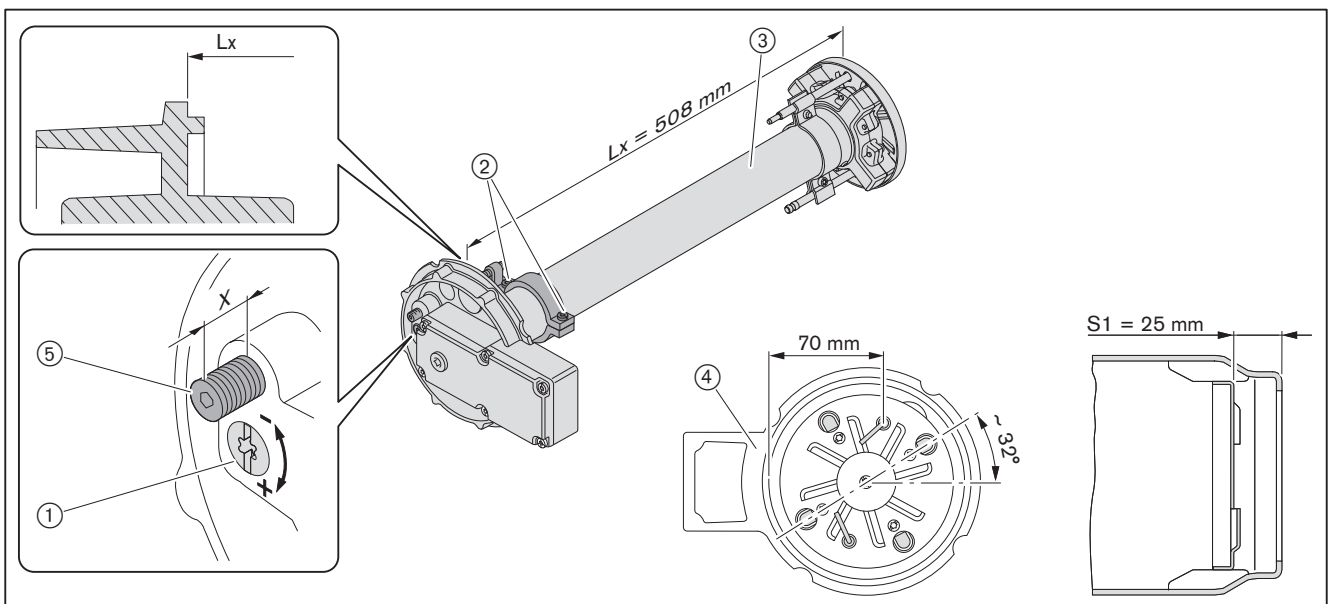

9.5 Set ionisation and ignition electrodes

Observe notes on servicing [ch. 9.1].

- ▶ Remove mixing head [ch. 9.3].
- ▶ Undo screw ①.
- ▶ Set ignition electrode and re-tighten screw.
- ▶ Undo screw ②.
- ▶ Set ionisation electrode and re-tighten screw.

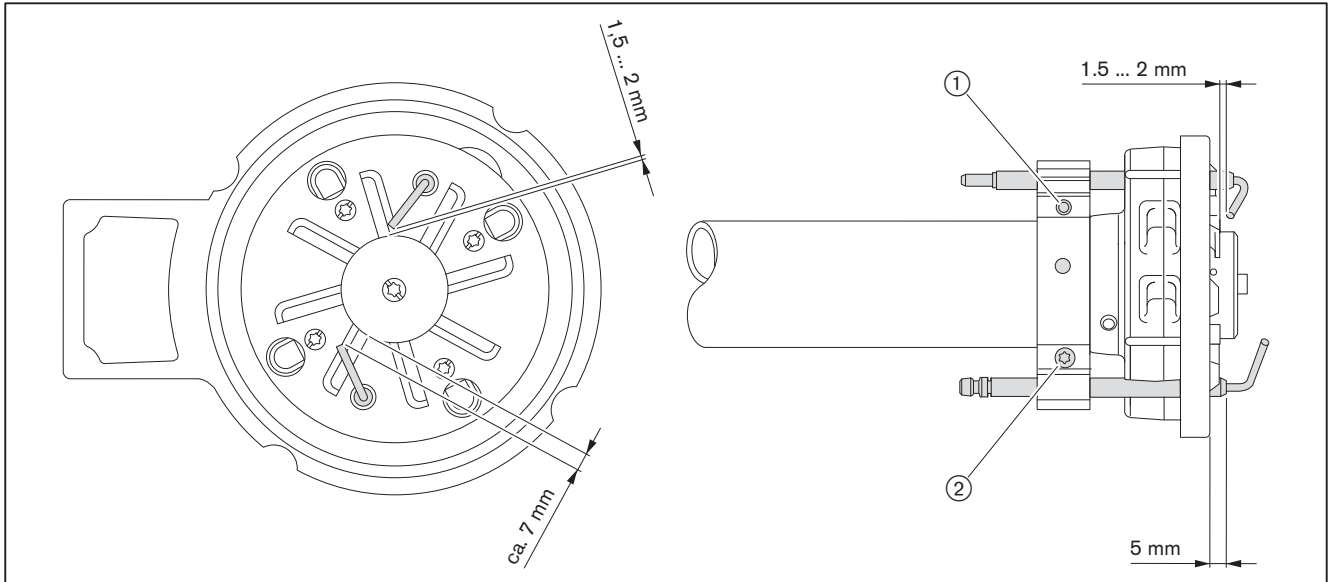

9.6 Service position

Observe notes on servicing [ch. 9.1].



The burner mounted rotated by 180° cannot be placed into the service position.

- ▶ Remove mixing head [ch. 9.3].
- ▶ Unplug plug ④ from ignition unit.
- ▶ Remove cover ② and remove plugs.
- ▶ Remove hoses ③.
- ▶ Hold housing cover and remove screws ①.
- ▶ Place housing cover onto hanging bolts ⑤.

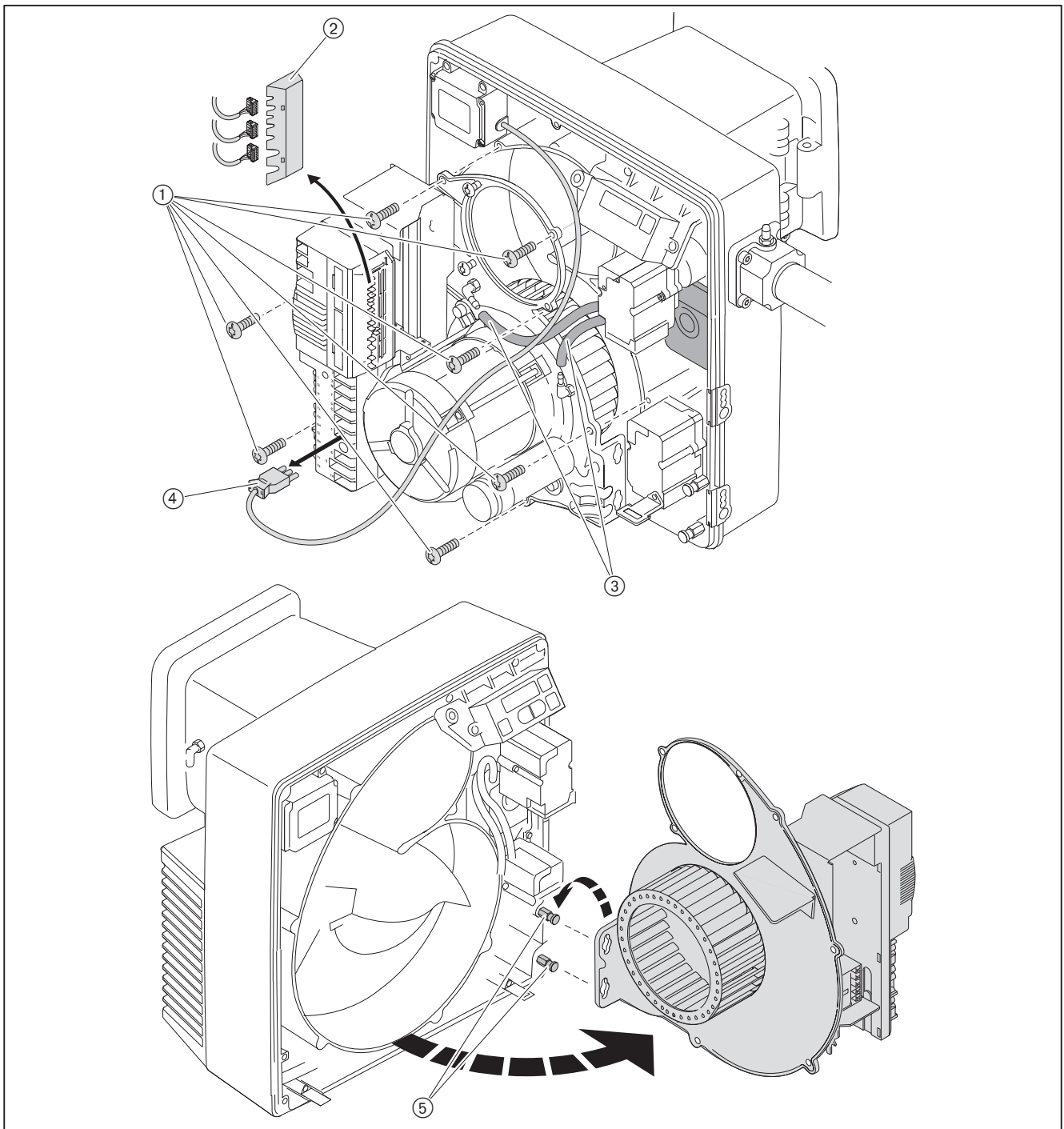

9.7 Removing and refitting fan wheel

Observe notes on servicing [ch. 9.1].

Removing

- ▶ Place housing cover into service position [ch. 9.6].
- ▶ Remove grub screw ① and remove fan wheel.

Refitting

- ▶ Refit fan wheel in reverse order and
 - ensure correct alignment of the spring washer ②,
 - screw in new grub screw ①,
 - turn fan wheel to ensure it moves freely.

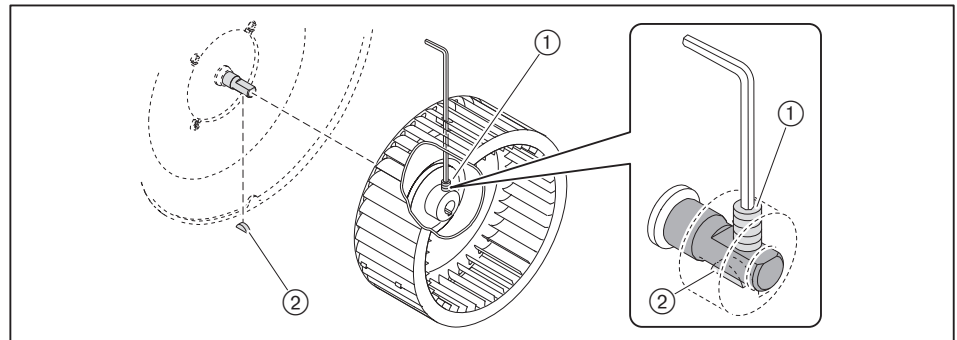

9 Servicing

9.8 Remove burner motor

Observe notes on servicing [ch. 9.1].

- ▶ Remove fan wheel [ch. 9.7].
- ▶ Unplug plug ①.
- ▶ Hold motor and remove screws ②.
- ▶ Remove motor.



Only in conjunction with variable speed drive

The variable speed drive sensor is fitted to the burner motor. If necessary remove variable speed drive sensor.

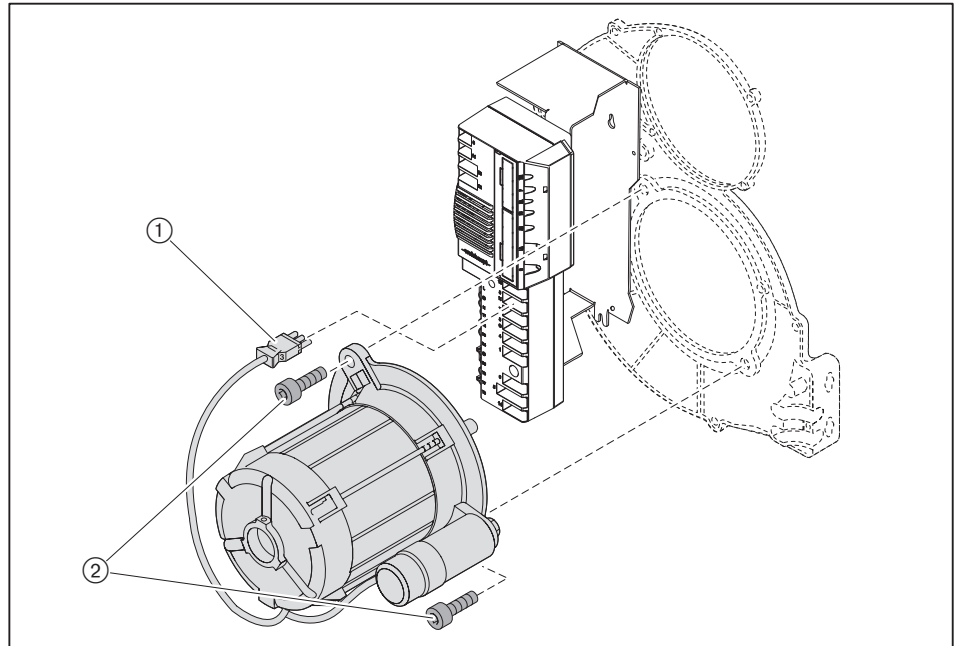

9.9 Removing and refitting air damper actuator

Observe notes on servicing [ch. 9.1].

Removing

- ▶ Remove actuator plug ④ from combustion manager.
- ▶ Remove screws ⑤.
- ▶ Remove actuator with fixing plate ③ and shaft ②.

Refitting



Damage to the actuator caused by turning the hub

Actuator could be damaged.

- ▶ Do not turn hub manually or with tool.

- ▶ Plug in actuator plug ④ at the combustion manager.
- ▶ Unplug bridging plug No. 7 on combustion manager.
- ▶ Switch on voltage supply.
- ✓ The combustion manager checks the actuator and drives to the reference point.
- ▶ Interrupt voltage supply.
- ▶ Fit shaft ② to actuator.
- ▶ Set indicator ① on angle drive to 0 (air damper Closed) and hold.
- ▶ Fit shaft with actuator to angle drive.
- ▶ Secure actuator.
- ▶ Plug in bridging plug No. 7 on combustion manager.

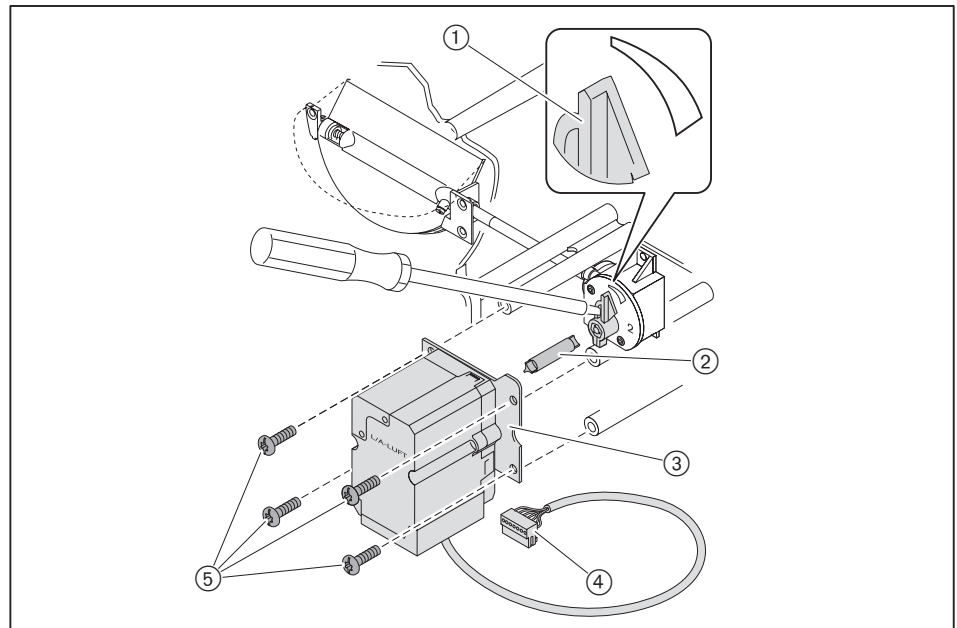

9 Servicing

9.10 Removing and refitting angle drive

Observe notes on servicing [ch. 9.1].

Removing

- ▶ Remove air damper actuator [ch. 9.9].
- ▶ Remove screws ②.
- ▶ Remove angle drive.

Refitting

- ▶ Turn shaft ① to its stop (air damper Open) and hold.
- ▶ Fit angle drive to shaft.
- ▶ Secure angle drive.

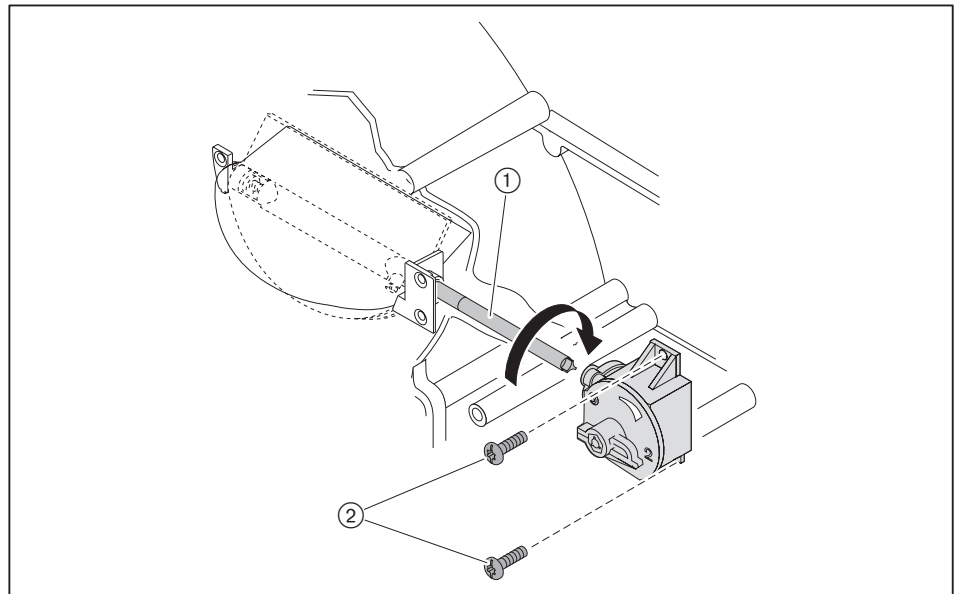

9.11 Removing and refitting gas butterfly valve actuator

Observe notes on servicing [ch. 9.1].

Removing

- ▶ Remove actuator plug ① from combustion manager.
- ▶ Remove screws ②.
- ▶ Remove actuator.

Refitting



Damage to the actuator caused by turning the hub

Actuator could be damaged.

- ▶ Do not turn hub manually or with tool.

- ▶ Plug in actuator plug ① at the combustion manager.
- ▶ Unplug bridging plug No. 7 on combustion manager.
- ▶ Switch on voltage supply.
- ✓ The combustion manager checks the actuator and drives to the reference point.
- ▶ Interrupt voltage supply.
- ▶ Fit actuator rotated by approx. 15°.
- ▶ Secure actuator.
- ▶ Plug in bridging plug No. 7 on combustion manager.

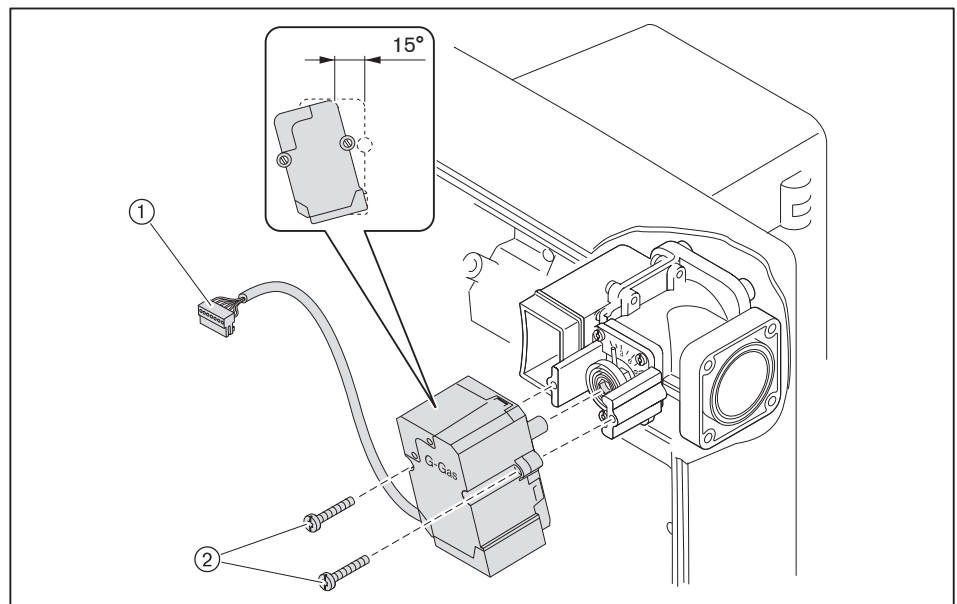

9 Servicing

9.12 Replacing double gas valve coil

Observe notes on servicing [ch. 9.1].



Ensure correct voltage and solenoid number when replacing the solenoid coil.

- ▶ Undo screw(s) ①.
- ▶ Remove cap ②.
- ▶ With DMV also remove metal plate ④.
- ▶ Replace solenoid coil ③.

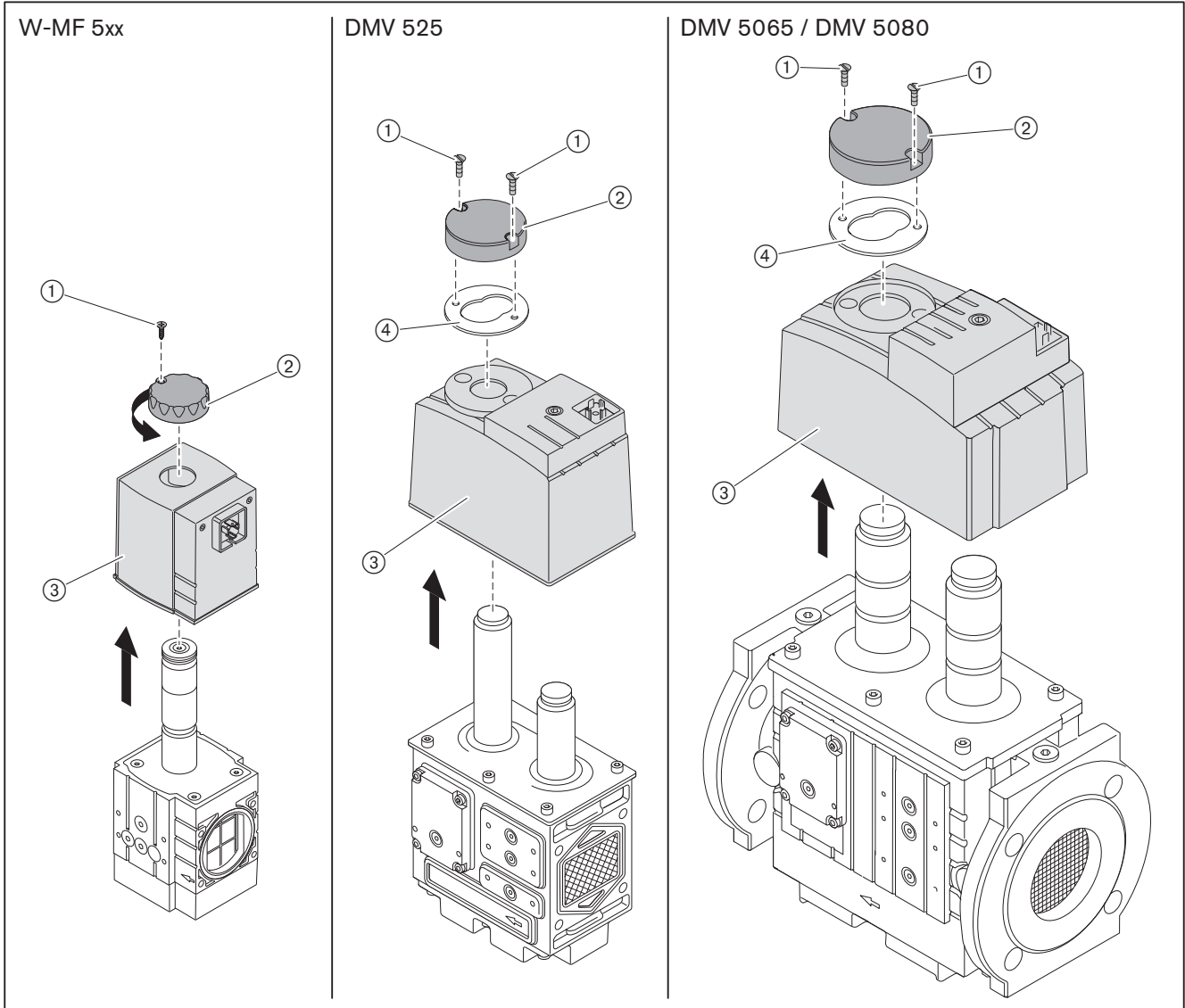

9.13 Replace breather plug of multifunction assembly

Observe notes on servicing [ch. 9.1].

A breather plug with integrated filter is fitted to protect the breather orifice against soiling.

- Replace breather plug ①.

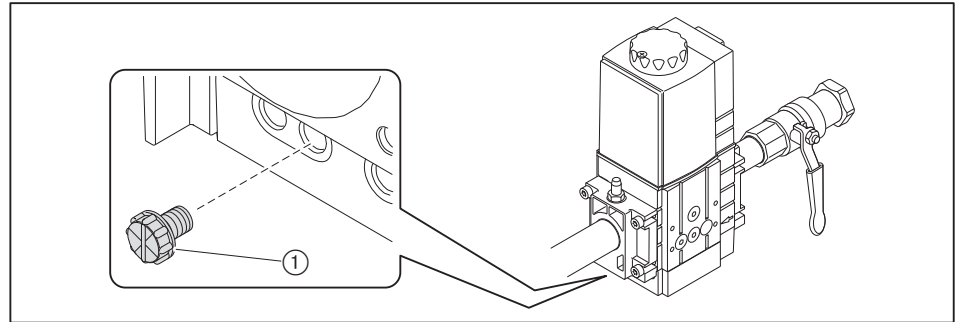

9 Servicing

9.14 Removing and refitting filter insert of multifunction assembly

Observe notes on servicing [ch. 9.1].



Ensure no dirt enters the multifunction assembly when removing and replacing the filter insert.

Removing

- ▶ Remove screws ④.
- ▶ Remove cover ③.
- ▶ Remove filter insert ①.
- ▶ If necessary replace filter insert ① and seal ②.

Refitting

- ▶ Refit in reverse order ensuring correct alignment of filter ① and seal ②.

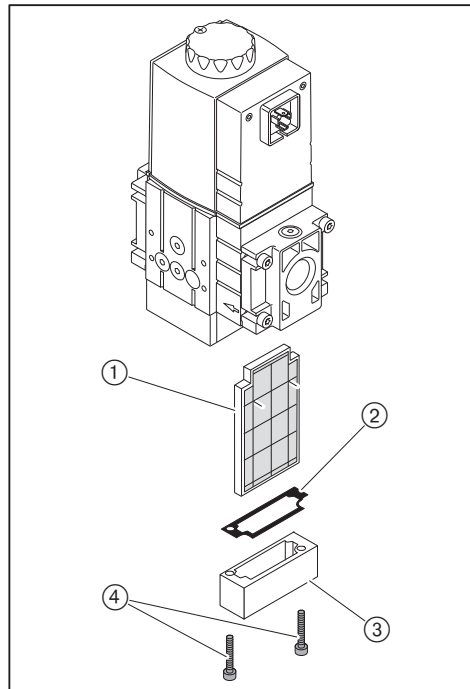

- ▶ Carry out soundness test [ch. 7.1.3].
- ▶ Vent gas valve train [ch. 7.1.4].

9.15 Removing and refitting filter insert in gas filter

Observe notes on servicing [ch. 9.1].



Ensure no dirt enters the multifunction assembly when removing and replacing the filter insert.

Removing

- ▶ Remove screws ①.
- ▶ Remove cover ②.
- ▶ Remove filter insert ④.
- ▶ If necessary replace filter insert ④ and O ring ③.

Refitting

- ▶ Refit in reverse order ensuring correct alignment of filter insert ④ and O ring ③.

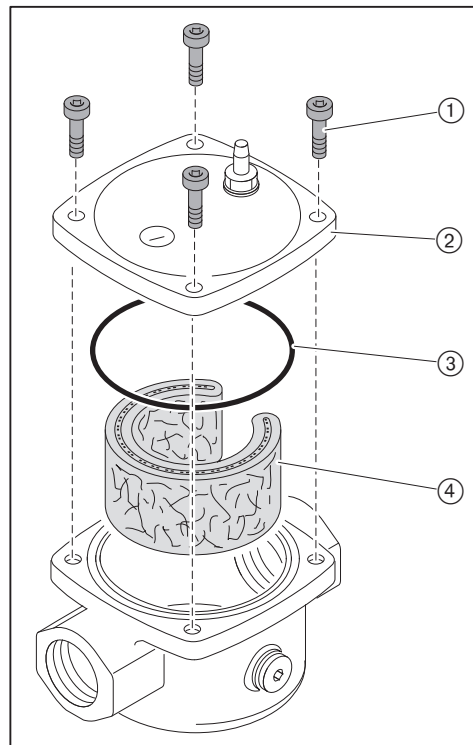

- ▶ Carry out soundness test [ch. 7.1.3].
- ▶ Vent gas valve train [ch. 7.1.4].

9 Servicing

9.16 Replacing the combustion manager

Observe notes on servicing [ch. 9.1].

- ▶ Unplug all plugs.
- ▶ Undo screws ①.
- ▶ Push combustion manager upwards and replace.

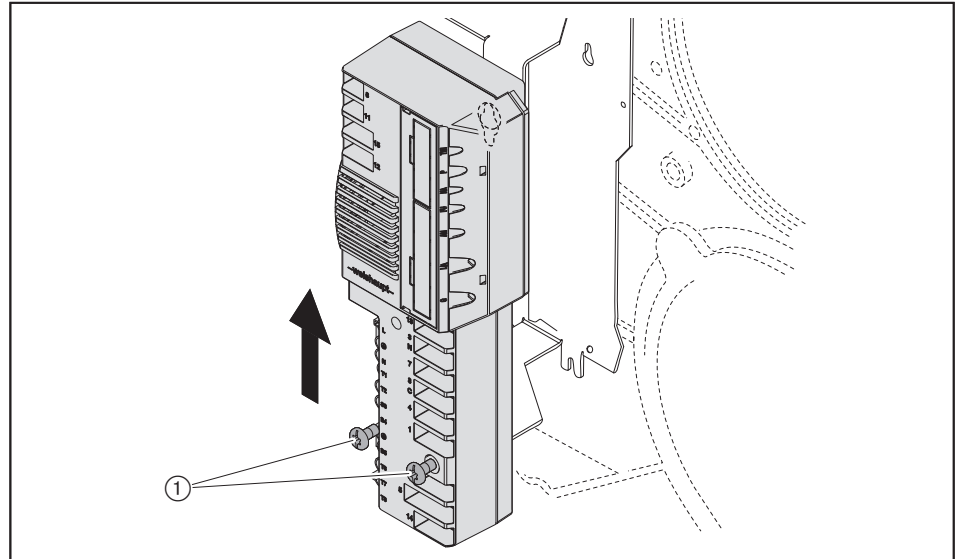

- ▶ Connect all plugs again.

Preset combustion manager

- ▶ Unplug bridging plug No. 7 on combustion manager.
- ▶ Switch on voltage supply.
- ✓ The unprogrammed condition of the combustion manager is indicated by a flashing display.
The burner goes to lockout.

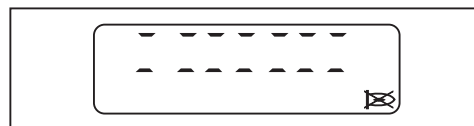

- ▶ Press [ENTER].
- ✓ Burner has been reset.
- ✓ Combustion manager drives to Standby.



- ▶ Press [G] and [L/A] simultaneously.
- ✓ Combustion manager changes to access level.



- ▶ Press [+].
- ✓ Setting level (parameter E0) is displayed.

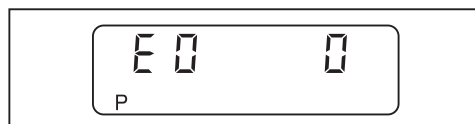

- ▶ Adopt value 0 (single fuel burner), if necessary adjust using [ENTER] and [-] key.
- ▶ Press [+].
- ✓ E1 is displayed.

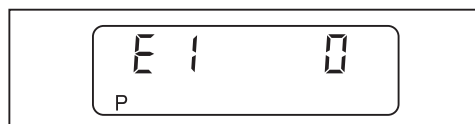

The value of parameter E1 can not be altered.

- 0: intermittent operation (Standard)
- 1: continuous operation

- ▶ Press [+].
- ✓ E2 is displayed.

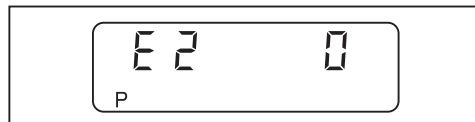

- ▶ Adopt value 0 (ionisation electrode), if necessary adjust using [ENTER] and [-] key.
- ▶ Press [+].
- ✓ E3 is displayed.

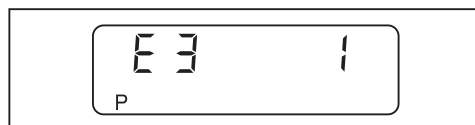

- ▶ If required, set value using [ENTER] and [+] keys.
- 1 (fan control): burner without variable speed drive
- 3 (variable speed drive): burner with variable speed drive
- ▶ Press [+].
- ✓ Combustion manager changes into the setting level for step points.

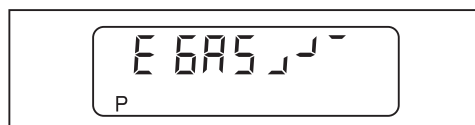

9 Servicing

- ▶ Determine the operating points from the sticker ①.
- ▶ Set the burner using these operating points and adjust [ch. 7.2].

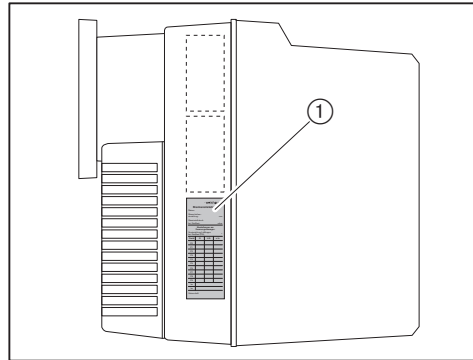

Deactivate E-Parameters

Following commissioning, set parameter E to 0.

- ▶ Press [Enter] and [+] keys simultaneously for approx. 2 seconds.
- ✓ The parameter level is activated.
- ▶ Press [+].
- ▶ Press [Enter] key until parameter E is displayed.
- ▶ Set parameter E to 0 .
- ✓ E -Parameters are not shown in the setting level.
- ▶ Press [Enter] key twice.
- ✓ The combustion manager returns to the operating level.

9.17 Replacing the fuse

Observe notes on servicing [ch. 9.1].

- ▶ Unplug connection plug from combustion manager.
- ▶ Replace fuse (T6,3H, IEC 127-2/5).

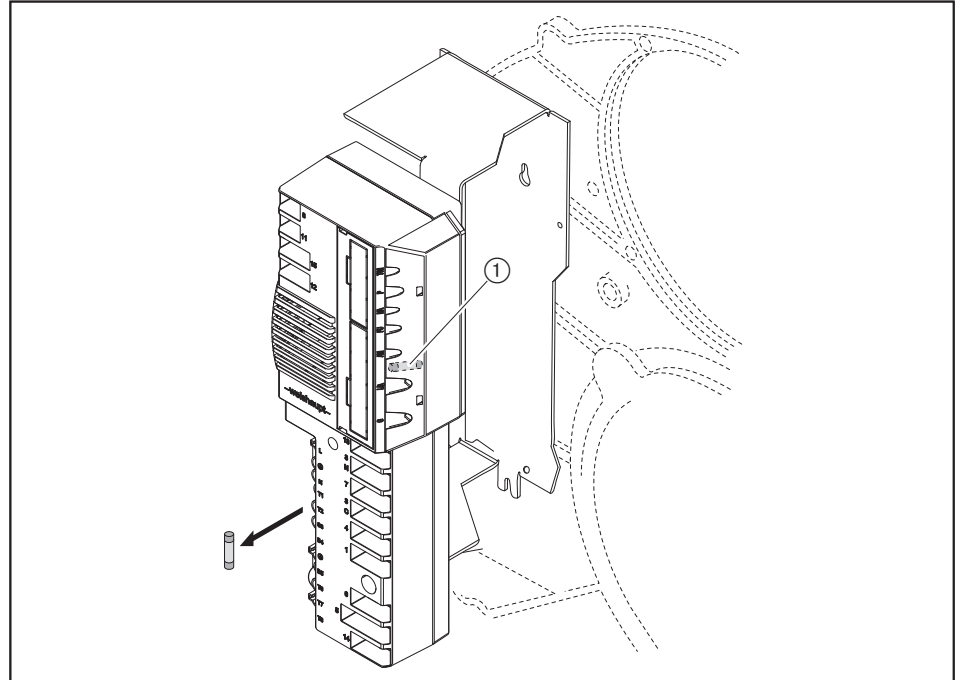

① Replacement fuse

10 Troubleshooting

10 Troubleshooting

10.1 Procedures for fault conditions

The combustion manager recognises irregularities of the burner and displays these on the display and operating unit.

The following conditions can occur:

- Display off [ch. 10.1.1],
- Display OFF [ch. 10.1.2]
- Display flashes [ch. 10.1.3].

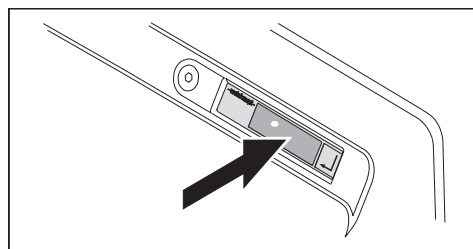

10.1.1 Display off

The following faults may be corrected by the operator:

Fault	Cause	Rectification
Burner not operating	External fuse has tripped ⁽¹⁾	▶ Check fuse.
	Heating switch is set to Off	▶ Switch on heating switch.
	Temperature limiter or pressure limiter on heat exchanger has triggered ⁽¹⁾	▶ Reset temperature limiter or pressure limiter on heat exchanger.
	Low water safety interlock on heat exchanger has triggered ⁽¹⁾	▶ Top up water. ▶ Reset low water safety interlock on heat exchanger.

⁽¹⁾ Notify your heating contractor or Weishaupt Customer Service if the problem occurs repeatedly.

10.1.2 Display OFF



The following faults may be corrected by the operator:

Fault	Cause	Rectification
Burner not operating	Temperature regulator or pressure regulator on heat exchanger has been set incorrectly	▶ Adjust temperature regulator or pressure regulator on heat exchanger.
	Boiler or heating circuit control is not functioning or has not been set correctly	▶ Check function and setting of boiler or heating circuit control.

10.1.3 Display flashes

A burner fault has occurred. The burner is in lockout. The error code is displayed flashing.

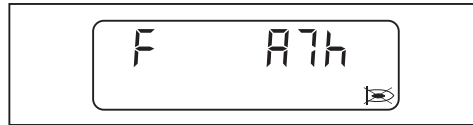

- ▶ Read error code, e. g. A7h.
- ▶ Rectify cause of fault [ch. 10.2].

Resetting



Damage resulting from incorrect fault repair

Incorrect fault repair can cause damage to the equipment and injure personnel.

- ▶ Do not carry out more than 2 lockout resets successively.
- ▶ Faults must be rectified by qualified personnel.

- ▶ Press [ENTER].
- ✓ Burner has been reset.

Fault memory

The last 9 faults are saved in the fault memory [ch. 6.2.2].

10 Troubleshooting

10.1.4 Detailed fault codes

Additional information, which breaks down the error in more detail, can be displayed by pressing a button.

The first detailed fault code and the second detailed fault code are only relevant for the following faults:

- 03h,
- 18h,
- 41h,
- 65h.

First detailed fault code / operating status

► Press [+] key.

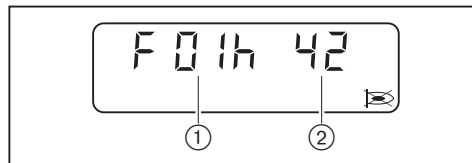

- ① First detailed fault code
- ② Operating status

Second detailed fault code

► Press [-] and [+] keys simultaneously.



Repetition counter

► Press key [G].

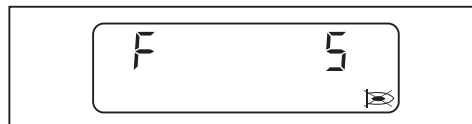

10.2 Rectifying faults

The following faults must only be rectified by qualified personnel:

Fault codes	Cause	Rectification
01h ... 02h 05h ... 0bh 0dh ... 10h 13h ... 15h 17h 19h ... 1Ch 1Eh 43h 45h 50h 56h A0h ACh b0h ... b2h b9h	Internal unit fault	<ul style="list-style-type: none"> ▶ Interrupt the voltage supply temporarily ▶ Reset the burner, if fault reoccurs replace the combustion manager [ch. 9.16]

The following faults must only be rectified by qualified personnel:

Fault codes	Cause	Rectification
03h	Ambient temperature too high	<ul style="list-style-type: none"> ▶ Interrupt the voltage supply temporarily ▶ Check ambient temperature [ch. 3.4.3] ▶ Reset the burner, if fault reoccurs replace the combustion manager [ch. 9.16]
	Internal unit fault	<ul style="list-style-type: none"> ▶ Interrupt the voltage supply temporarily ▶ Reset the burner, if fault reoccurs replace the combustion manager [ch. 9.16]
04h	More than 5 resets in the last 15 minutes	<ul style="list-style-type: none"> ▶ Press and hold reset key for 5 seconds. ✓ Display flashes. ▶ Reset burner
0Ch	Burner configuration incorrect	<ul style="list-style-type: none"> ▶ Check burner configuration ▶ Check values in parameter level [ch. 6.2.3] ▶ Check parameter E0 ... E3 [ch. 6.2.4]
	Pre-purge phase less than 20 seconds (sum from parameters 60 and 61).	<ul style="list-style-type: none"> ▶ Increase pre-purge phase (only possible with VisionBox).
11h	Low voltage	<ul style="list-style-type: none"> ▶ Check voltage supply
12h	Voltage supply was temporarily interrupted	<ul style="list-style-type: none"> ▶ Check voltage supply
16h	Communication with TWI interface (VisionBox) incorrect	<ul style="list-style-type: none"> ▶ Plug in and unplug participants on the TWI Bus only when de-energised ▶ Reduce the number of participants on the TWI Bus ▶ Reduce cable length

10 Troubleshooting

The following faults must only be rectified by qualified personnel:

Fault codes	Cause	Rectification
18h	Switch off via PC Software	–
	Second detailed fault code: A1h Invalid Bus address	▶ Check Bus address
	Second detailed fault code: A5h Configuration at output B4 incorrect	▶ Check configuration at output B4
	Second detailed fault code: A6h No keystrokes where made for 30 minutes in the setting mode	–
	Second detailed fault code: A7h Off function was activated	–
	Second detailed fault code: A8h No calibration values were stored in the EEPROM	–
	Second detailed fault code: A9h No Bus connection	▶ Check Bus connection
	Second detailed fault code: 01h ... 1Bh Internal unit fault	▶ Interrupt the voltage supply temporarily ▶ Reset the burner, if fault reoccurs replace the combustion manager [ch. 9.16]
	Second detailed fault code: E1h ... E7h Calibration values in EEPROM incorrect	–
	Second detailed fault code: EEh Communication to W-FM 25 failed	–
	Second detailed fault code: EFh Extension module to W-FM 25 not compatible	▶ Check version
1dh	EMC interference	▶ Optimise EMC measures.
40h	Speed standardisation outside of limits set	▶ Carry out speed standardisation
41h	First detailed fault code: 01h Speed differs for too long	▶ Check parameters 44 and 45
	First detailed fault code: 02h Speed difference is too great	▶ Check speed signal
	First detailed fault code: 03h Speed setting value outside of tolerance for too long	▶ Re-adjust burner ▶ Check parameters 44 and 45
42h	Speed signal (Namur) not plugged in	▶ Plug in speed signal
44h	Operating points were changed without approval	▶ Re-adjust burner
	Parameter E3 set incorrectly	▶ Check parameter E3 [ch. 6.2.4].
	Parameter 46 was changed and speed was not re-standardised	▶ Re-adjust burner
46h	Rotational direction of burner incorrect	▶ Check rotation direction of burner motor
47h	Type of air actuator invalid	▶ Check parameter 34 (only possible with Vision-Box).
	Type of gas actuator invalid	▶ Check parameter 35 (only possible with Vision-Box).
48h	Plugs of actuators for gas and air mixed up	▶ Change over plugs
	Tolerance fault actuator	▶ Check freedom of movement of air damper and / or angle drive and gas butterfly valve ▶ Replace actuator

The following faults must only be rectified by qualified personnel:

Fault codes	Cause	Rectification
49h	Actuator does not drive to reference point correctly	<ul style="list-style-type: none"> ▶ Check freedom of movement of air damper and / or angle drive and gas butterfly valve ▶ Replace actuator
53h	Insufficient gas, low gas pressure switch/ valve proving gas pressure switch	<ul style="list-style-type: none"> ▶ Check gas connection pressure [ch. 7.1.5] ▶ Set gas pressure switch [ch. 7.3.1] ▶ Check gas pressure switch
63h	Speed learning curve incorrect	<ul style="list-style-type: none"> ▶ Re-adjust burner
65h	First detailed fault code: 00h Tolerance fault air actuator, gas actuator or frequency converter	<ul style="list-style-type: none"> ▶ Check freedom of movement of air damper and / or angle drive ▶ Check freedom of movement of gas butterfly valve ▶ Replace actuator ▶ Check frequency converter or fan, replace if necessary
	First detailed fault code: 01h Tolerance fault air actuator or gas actuator	<ul style="list-style-type: none"> ▶ Check freedom of movement of air damper and / or angle drive ▶ Check freedom of movement of gas butterfly valve ▶ Replace actuator
	First detailed fault code: 02h Tolerance fault gas actuator or frequency converter	<ul style="list-style-type: none"> ▶ Check freedom of movement of gas butterfly valve ▶ Replace actuator ▶ Check frequency converter or fan, replace if necessary
	First detailed fault code: 03h Tolerance fault gas actuator	<ul style="list-style-type: none"> ▶ Check freedom of movement of gas butterfly valve ▶ Replace actuator
	First detailed fault code: 04h Tolerance fault air actuator or frequency converter	<ul style="list-style-type: none"> ▶ Check freedom of movement of air damper and / or angle drive ▶ Replace actuator ▶ Check frequency converter or fan, replace if necessary
	First detailed fault code: 05h Tolerance fault air actuator	<ul style="list-style-type: none"> ▶ Check freedom of movement of air damper and / or angle drive ▶ Replace actuator
	First detailed fault code: 06h Tolerance fault frequency converter	<ul style="list-style-type: none"> ▶ Check frequency converter or fan, replace if necessary
	First detailed fault code: 07h Time run out during speed standardisation Time in setting mode run out Plugs of actuators for gas and air mixed up	<ul style="list-style-type: none"> ▶ Press [+] key within 20 seconds during speed standardisation ▶ Press key within 30 minutes in setting mode ▶ Change over plugs
A2h	Safety circuit is open	<ul style="list-style-type: none"> ▶ Check safety circuit
A4h	Reverse voltage valve 1	<ul style="list-style-type: none"> ▶ Check wiring to double solenoid valve
A5h	Reverse voltage valve 2	<ul style="list-style-type: none"> ▶ Check wiring to double solenoid valve
A6h	Flame simulation/extraneous light	<ul style="list-style-type: none"> ▶ Find and eliminate extraneous light source ▶ Check ionisation electrode

10 Troubleshooting

The following faults must only be rectified by qualified personnel:

Fault codes	Cause	Rectification
A7h	No flame signal after safety time	<ul style="list-style-type: none"> ▶ Set ignition electrode [ch. 9.5] ▶ Check the ignition unit and replace if necessary ▶ Check solenoid valve coil and cable, replace if necessary ▶ Check the ionisation electrode and cable, replace if necessary. ▶ Check mixing pressure, if necessary reduce ▶ Check burner setting ▶ Replace combustion manager [ch. 9.16]
A8h	Flame failure during operation	<ul style="list-style-type: none"> ▶ Check burner setting ▶ Check the ionisation electrode, replace if necessary [ch. 9.5].
A9h	Flame failure during stabilisation time	▶ see A7h
AAh	Switch contact of air pressure switch not in Standby	<ul style="list-style-type: none"> ▶ Check air pressure influences ▶ Check air pressure switch setting [ch. 7.3.2] ▶ Check air pressure switch and cable, replace if necessary ▶ Replace combustion manager [ch. 9.16]
Abh	Air pressure switch does not react	<ul style="list-style-type: none"> ▶ Check air pressure switch setting [ch. 7.3.2] ▶ Check hoses on air pressure switch ▶ Check air pressure switch and cable, replace if necessary ▶ Check burner motor and cable, replace if necessary [ch. 9.8]
Adh	Insufficient gas low gas pressure switch	<ul style="list-style-type: none"> ▶ Check gas connection pressure [ch. 7.1.5] ▶ Set gas pressure switch [ch. 7.3.1] ▶ Check gas pressure switch
AEh	Valve 1 leaking during valve proving	<ul style="list-style-type: none"> ▶ Check soundness of gas valve train [ch. 7.1.3] ▶ Check setting and function of gas pressure switch [ch. 7.3.1] ▶ Replace double gas valve ▶ Check parameter E0 [ch. 6.2.4].
AFh	Valve 2 leaking during valve proving	<ul style="list-style-type: none"> ▶ Check soundness of gas valve train [ch. 7.1.3] ▶ Check setting and function of gas pressure switch [ch. 7.3.1] ▶ Replace double gas valve
b6h	Fault POC contact	<ul style="list-style-type: none"> ▶ Check POC contact ▶ Check double gas valve (valve 1)
bAh	Flame simulation/extraneous light at start-up	<ul style="list-style-type: none"> ▶ Find and eliminate extraneous light source ▶ Check ionisation electrode
bbh	Burner shutdown via contact X3:7 (plug No. 7)	–
CAh	Valve proving faulty	<ul style="list-style-type: none"> ▶ Check low gas pressure switch/valve proving gas pressure switch ▶ Check double gas valve
Cdh	No signal on input X3:15	▶ Check wiring
CEh	Bridging plug No. 15 is missing	▶ Plug in bridging plug
	High gas pressure switch does not react	<ul style="list-style-type: none"> ▶ Check gas connection pressure [ch. 7.1.5] ▶ Set gas pressure switch ▶ Check gas pressure switch
CFh	No start release (X3:14)	▶ Check start release

The following faults must only be rectified by qualified personnel:

Fault codes	Cause	Rectification
d1h	Connection to actuator faulty	<ul style="list-style-type: none"> ▶ Rectify the fault using the following procedure: <ul style="list-style-type: none"> ▪ Interrupt voltage supply. ▪ Plug in plug on combustion manager correctly ▪ Fit W-FM cover [ch. 3.3.4].
	Parameter E0 not configured correctly	<ul style="list-style-type: none"> ▶ Check configuration of parameter E0 see [ch. 6.2.4].
d2h	More than 5 resets in the past 15 minutes by remote reset (X3:14)	<ul style="list-style-type: none"> ▶ Rectify cause of fault ▶ Reset via operating panel on burner. ▶ Press and hold reset key for 5 seconds. ✓ Display flashes. ▶ Reset burner
d4h	External voltage at operating signal X7:B5	<ul style="list-style-type: none"> ▶ Find and eliminate external voltage source
	Internal unit fault	<ul style="list-style-type: none"> ▶ Interrupt the voltage supply temporarily ▶ Reset the burner, if fault reoccurs replace the combustion manager [ch. 9.16]

10.3 Operating problems

The following faults must only be rectified by qualified personnel:

Observation	Cause	Rectification
Poor start behaviour of burner	Mixing pressure too high	<ul style="list-style-type: none"> ▶ Reduce mixing pressure in ignition position
	Ignition electrode set incorrectly	<ul style="list-style-type: none"> ▶ Set ignition electrode [ch. 9.5]
	Mixing head set incorrectly	<ul style="list-style-type: none"> ▶ Set mixing head [ch. 9.4]
Combustion pulsating or burner booming	Mixing head set incorrectly	<ul style="list-style-type: none"> ▶ Set mixing head [ch. 9.4]
	Incorrect combustion air quantity	<ul style="list-style-type: none"> ▶ Adjust burner
Stability problems	Mixing pressure too high	<ul style="list-style-type: none"> ▶ Decrease mixing pressure
No display at operating panel	Plug from operating panel not properly plugged in	<ul style="list-style-type: none"> ▶ Plug in plug on combustion manager correctly
	Operating panel defective	<ul style="list-style-type: none"> ▶ Replace operating panel

11 Technical documentation

11 Technical documentation

11.1 Program sequence

The exact operating status of the combustion manager can also be displayed. Activate operating status [ch. 6].

Operating phase	Operating status	Condition / function
F . .	00	Fault present
OFFUPr	01	Unprogrammed condition or programming not completed
OFF	02	Standby, no heat demand
1	03	Extraneous light check
2	04	Shutdown check air pressure switch
	05	Initialisation W-FM
	06	Waiting for start release / waiting time O ₂ trim
	07	Internal sequence
3	08	Driving air damper actuator to pre-purge and gas butterfly valve actuator to ignition position
	09	Waiting for speed standardisation confirmation
	10	Start burner motor
4	11	Waiting for air pressure
	12	Pre-purge
5	13	Internal sequence
	14	Driving air damper actuator to ignition position
6	15	Gas pressure check on low / valve proving gas pressure switch
	16	Ignition
7	17	First safety time - fuel release
	18	First safety time - flame detection
8	19	First stabilisation time
	20	Stop setting mode: P0 -A
	21	Second safety time
	22	Second stabilisation time
	23	End setting mode: P0 -B
9	24	Driving to partial load
10	25	Operation (load control is activated)
11	34	Valve proving - venting valve interspace
12	35	Valve proving - test time valve 1
	36	Internal sequence
13	37	Valve proving - filling valve interspace
14	38	Valve proving - test time valve 2
	39	Internal sequence
15	26	Internal sequence
	27	Driving to partial load
	28	Close fuel valves
	29	Internal sequence
	30	Start post burn time / post-purge
	31	Post-purge contact dependent (X3:14)
	32	Post burn time

Operating phase	Operating status	Condition / function
16	33	Restart interlock
G L	40	Reference search actuator - air damper and gas butterfly valve
G	41	Test gas butterfly valve actuator 105°
G L	42	Drive to Standby position
	43	Internal sequence
OFFGd	44	Insufficient gas, low gas pressure switch (X3:14)
16	45	Low gas programme
OFF S	46	Safety circuit open (X3:7)

11.2 Conversion table unit of pressure

Bar	Pascal			
	Pa	hPa	kPa	MPa
0.1 mbar	10	0.1	0.01	0.00001
1 mbar	100	1	0.1	0.0001
10 mbar	1 000	10	1	0.001
100 mbar	10 000	100	10	0.01
1 bar	100 000	1 000	100	0.1
10 bar	1 000 000	10 000	1 000	1

11.3 Appliance categories

Labelling of gas and dual fuel burners to EN 676

EN 676, "Forced draught burners for gaseous fuels", is used for the implementation of the basic requirements of the directive (EU) 2016/426.

EN 676 stipulate the following appliance categories for forced draught gas burners under Point 4.4.9:

I2R	for Natural Gas
I3R	for Liquid Petroleum Gas
II2R/3R	for Natural Gas / Liquid Petroleum Gas

The test gases listed under point 5.1.1, table 4 and the minimum test pressures determined and listed under point 5.1.2, table 5 are used to provide the evidence of service performance of the burner during type testing.

As -weishaupt- gas and dual fuel burners fulfil this requirement completely, the appliance category, as well as the test gases used with the permissible connection pressure range, are listed on the name plate when labelling the burner to point 6.2. This clearly defines the suitability of the burner for use with second or third family gases.

On the basis of a type test report to ISO 17025 from an accredited test centre, the EU Type Testing Certificate to Directive (EU) 2016/426 also quotes the appliance category, the supply pressure and the country of destination.

EN 437, "Test gases - test pressures - appliance categories", describes the interrelationships and the special national characteristics relating to this subject in detail.

The following tables give an overview of the interrelationships between the R Categories and the nationally used appliance categories with their types of gas and connection pressures.

Alternative appliance category to I2R

Country of destination	Appliance category	Test gas	Connection pressure mbar
AL (Albania)	I2H	G 20	20
AT (Austria)	I2H	G 20	20
BA (Bosnia)	I2H	G 20	20
BE (Belgium)	I2E+, I2N, I2E(R)B	G 20 + G 25	Pressures 20 / 25
BG (Bulgaria)	I2H	G 20	20
BY (Belarus)			
CH (Switzerland)	I2H	G 20	20
CY (Cyprus)	I2H	G 20	20
CZ (Czech Republic)	I2H	G 20	20
DE (Germany)	I2ELL, I2E, I2L	G 20 / G 25	20
DK (Denmark)	I2H	G 20	20
EE (Estonia)	I2H	G 20	
ES (Spain)	I2H	G 20	20
FI (Finland)	I2H	G 20	20
FR (France)	I2Esi, I2E+, I2L	G 20 + G 25	Pressures 20 / 25
GB (United Kingdom)	I2H	G 20	20
GR (Greece)	I2H	G 20	20
HR (Croatia)	I2H	G 20	20
HU (Hungary)	I2H	G 20	20
IE (Ireland)	I2H	G 20	20
IS (Iceland)	I2H	G 20	20
IT (Italy)	I2H	G 20	20
LT (Lithuania)			
LU (Luxembourg)	I2E	G 20	20
LV (Latvia)			
MD (Moldova)	I2H	G 20	20
MK (Macedonia)	I2H	G 20	20
MT (Malta)	I2H	G 20	20
NL (The Netherlands)	I2L, I2EK	G 25	25
NO (Norway)	I2H	G 20	20
PL (Poland)	I2E	G 20 / GZ 410	20
PT (Portugal)	I2H	G 20	20
RO (Romania)	I2H	G 20	20
SE (Sweden)	I2H	G 20	20
SI (Slovenia)	I2H	G 20	20
SK (Slovakia)	I2H	G 20	20
SRB (Serbia)	I2H	G 20	20
TR (Turkey)	I2H	G 20	25
UA (Ukraine)	I2H	G 20	20

Alternative appliance category to I3R

Country of destination	Appliance category	Test gas	Connection pressure mbar
AL (Albania)	I3+, I3P, I3B	G 30 + G 31	Pressures 28 - 30 / 37
AT (Austria)	I3B/P, I3P	G 30 + G 31	50
BA (Bosnia)	I3B/P	G 30	30 (28-30)
BE (Belgium)	I3+, I3P, I3B, I3B/P	G 30 + G 31	Pressures 28 - 30 / 37
BG (Bulgaria)	I3+, I3P, I3B	G 30 + G 31	Pressures 28 - 30 / 37
BY (Belarus)			
CH (Switzerland)	I3B/P, I3+, I3P	G 30 + G 31	Pressures 28 - 30 / 37
CY (Cyprus)	I3B/P, I3+, I3P, I3B	G 30 + G 31	Pressures 28 - 30 / 37
CZ (Czech Republic)	I3B/P, I3+, I3P	G 30 + G 31	Pressures 28 - 30 / 37
DE (Germany)	I3B/P, I3P	G 30 + G 31	50
DK (Denmark)	I3B/P	G 30 + G 31	30 (28 - 30)
EE (Estonia)	I3B/P	G 30	
ES (Spain)	I3+, I3P, I3B	G 30 + G 31	Pressures 28 - 30 / 37
FI (Finland)	I3B/P	G 30 + G 31	30 (28 - 30)
FR (France)	I3+, I3P, I3B	G 30 G 31	Pressures 28 - 30 / 37 Pressures 112 / 148
GB (United Kingdom)	I3+, I3P, I3B	G 30 + G 31	Pressures 28 - 30 / 37
GR (Greece)	I3B/P, I3+, I3P, I3B	G 30 + G 31	Pressures 28 - 30 / 37
HR (Croatia)	I3B/P, I3P	G 30 + G31	50
HU (Hungary)	I3B/P	G 30 + G31	50
IE (Ireland)	I3+, I3P, I3B	G 30 + G 31	Pressures 28 - 30 / 37
IS (Iceland)	I3B/P		
IT (Italy)	I3B/P, I3+, I3P	G 30 + G 31	Pressures 28 - 30 / 37
LT (Lithuania)			
LU (Luxembourg)	I3B/P	G 30	
LV (Latvia)			
MD (Moldova)	I3+, I3P, I3B	G 30 + G 31	Pressures 28 - 30 / 37
MK (Macedonia)	I3+, I3P, I3B	G 30 + G 31	Pressures 28 - 30 / 37
MT (Malta)	I3+, I3P, I3B	G 30 + G 31	Pressures 28 - 30 / 37
NL (The Netherlands)	I3B/P, I3P	G 30 + G 31	30 (28 - 30)
NO (Norway)	I3B/P	G 30 + G 31	30 (28 - 30)
PL (Poland)	I3B/P	G 30	
PT (Portugal)	I3+, I3P, I3B	G 30 G 31	Pressures 28 - 30 / 37 Pressures 50 / 67
RO (Romania)	I3B/P	G 30	
SE (Sweden)	I3B/P	G 30 + G 31	30 (28 - 30)
SI (Slovenia)	I3B/P	G 30	30
SK (Slovakia)	I3B/P	G 30	30
SRB (Serbia)	I3B/P, I3P	G 30 + G 31	20
TR (Turkey)	I3B/P	G 30 + G 31	30
UA (Ukraine)	I3B/P, I3P	G 30 + G 31	50

Alternative appliance category to II2R/3R

Country of destination	Appliance category	Test gas	Connection pressure mbar	Test gas	Connection pressure mbar
AL (Albania)	II2H3+, II2H3P	G 20	20	G 31	30
AT (Austria)	II2H3B/P, II2H3P	G 20	20	G 30 + G 31	50
BA (Bosnia)	II2H3B/P	G 20	20	G 30	
BE (Belgium)	II2E+3P, II2H3B/P	G 20, G 25	Pressures 20 / 25	G 30 + G 31	Pressures 28 - 30 / 37
BG (Bulgaria)	II2H3+, II2H3P	G 20	20	G 30 + G 31	Pressures 28 - 30 / 37
BY (Belarus)					
CH (Switzerland)	II1a2H, II2H3B/P, II2H3+, II2H3P	G 20	20	G 30 + G 31	Pressures 28 - 30 / 37
CY (Cyprus)	II2H3B/P, II2H3+, II2H3P	G20	20	G 30 + G 31	Pressures 28 - 30 / 37
CZ (Czech Republic)	II2H3B/P, II2H3+, II2H3P	G 20	20	G 30 + G 31	Pressures 28 - 30 / 37
DE (Germany)	II2ELL3B/P, II2E3B/P	G 20	20	G 30 + G 31	50
DK (Denmark)	II1a2H, II2H3B/P	G 20	G 20	G 30 + G 31	30
EE (Estonia)	II2H3B/P	G 20	20	G 30	30
ES (Spain)	II2H3P, II2H3+	G 20	20	G 30 + G 31	Pressures 28 - 30 / 37
FI (Finland)	II2H3B/P	G 20	20	G 30 + G 31	30 (28 - 30)
FR (France)	II2E+3+, II2E+3P, II2Esi3B/P	G 20	20	G 30 G 31	Pressures 28 - 30 / 37 Pressures 112 / 148
GB (United Kingdom)	II2H3+, II2H3P	G 20	20	G 30 + G 31	Pressures 28 - 30 / 37
GR (Greece)	II2H3B/P, II2H3+, II2H3P	G 20	20	G 30 + G 31	Pressures 28 - 30 / 37
HR (Croatia)	II2H3B/P	G 20	20	G 30 + G 31	30 (28-30)
HU (Hungary)	II2H3B/P	G 20	20	G 30 + G 31	
IE (Ireland)	II2H3+, II2H3P	G 20	20		
IS (Iceland)	II2H3B/P	G 20	20	G 30 + G 31	30 (28 - 30)
IT (Italy)	II1a2H, II2H3B/P, II2H3+, II2H3P	G 20	20	G 30 + G 31	Pressures 28 - 30 / 37
LT (Lithuania)					
LU (Luxembourg)	II2E3B/P	G 20	20	G 30 + G 31	
LV (Latvia)					
MD (Moldova)	II2H3+, II2H3P	G 20	20	G 30 + G 31	Pressures 30 / 37
MK (Macedonia)	II2H3+, II2H3P	G 20	20	G 30 + G 31	Pressures 30 / 37
MT (Malta)	II2H3+, II2H3P	G 20	20	G 30 + G 31	Pressures 30 / 37
NL (The Netherlands)	II2L3B/P, II2L3P, II2EK3B/P, II2EK3P	G 25	25	G 30 + G 31	30
NO (Norway)	II2H3B/P	G 20	20	G 30 + G 31	30 (28 - 30)
PL (Poland)	II2E3B/P	G 20	20	G 30 + G 31	30 (28 - 30)
PT (Portugal)	II2H3+, II2H3P	G 20	20	G 30 G 31	Pressures 28 - 30 / 37 Pressures 50 / 67
RO (Romania)	II2H3B/P	G 20	20	G 30 + G 31	30 (28 - 30)
SE (Sweden)	II1a2H, II2H3B/P	G 20	20	G 30 + G 31	30 (28 - 30)
SI (Slovenia)	II2H3B/P	G 20	20	G 30	30
SK (Slovakia)	II2H3B/P	G 20	20	G 30	30
SRB (Serbia)	II2H3B/P	G 20	20	G 30 + G 31	30 (28 - 30)
TR (Turkey)	II2H3B/P	G 20	25	G 30 + G 31	30 + 37
UA (Ukraine)	II2H3B/P	G 20	20	G 30 + G 31	30 (28 - 30)

12 Project planning

12 Project planning

12.1 Additional requirements

Additional requirements for burner for liquid and gaseous fuels in accordance with EN 676:

- the pressure equipment operates in accordance with the Pressure Equipment Directive 2014/68/EU,
- as components of industrial thermal process plants in accordance with EN 746-2,
- on steam and hot water water-tube boilers in accordance with EN 12952-8.

PED 2014/68/EU	EN 746-2	EN 12952-8	Components	Requirement
X			Burner control, combustion manager	Designed for continuous operation greater than 1200 kW
		X	Flame monitor, flame sensor	self-checking
X			Control device air/fuel ratio	EN 12067-2
X	X	X	Air monitoring device, air pressure switch	Min. pressure switch to EN 1854
X	X	X	Minimum fuel pressure monitoring device	Low gas pressure switch to EN 1854
X	X	X	Maximum fuel pressure monitoring device	High gas pressure switch to EN 1854
X	X	X	Valve monitoring system, valve proving gas pressure switch	EN 1643
X	X	X	Gas pressure regulator	EN 88, EN 334
X	X	X	Automatic safety shut off valves (PED: for aggressive media)	2 x Group A, EN 161
	X		Manual shut off device for all fuels	Isolating valve
	X		Safety devices for safe operation	Connected to the input of the combustion manager in the closed circuit current principle
		X	Electrical equipment	EN 50156

13 Spares

13 Spares

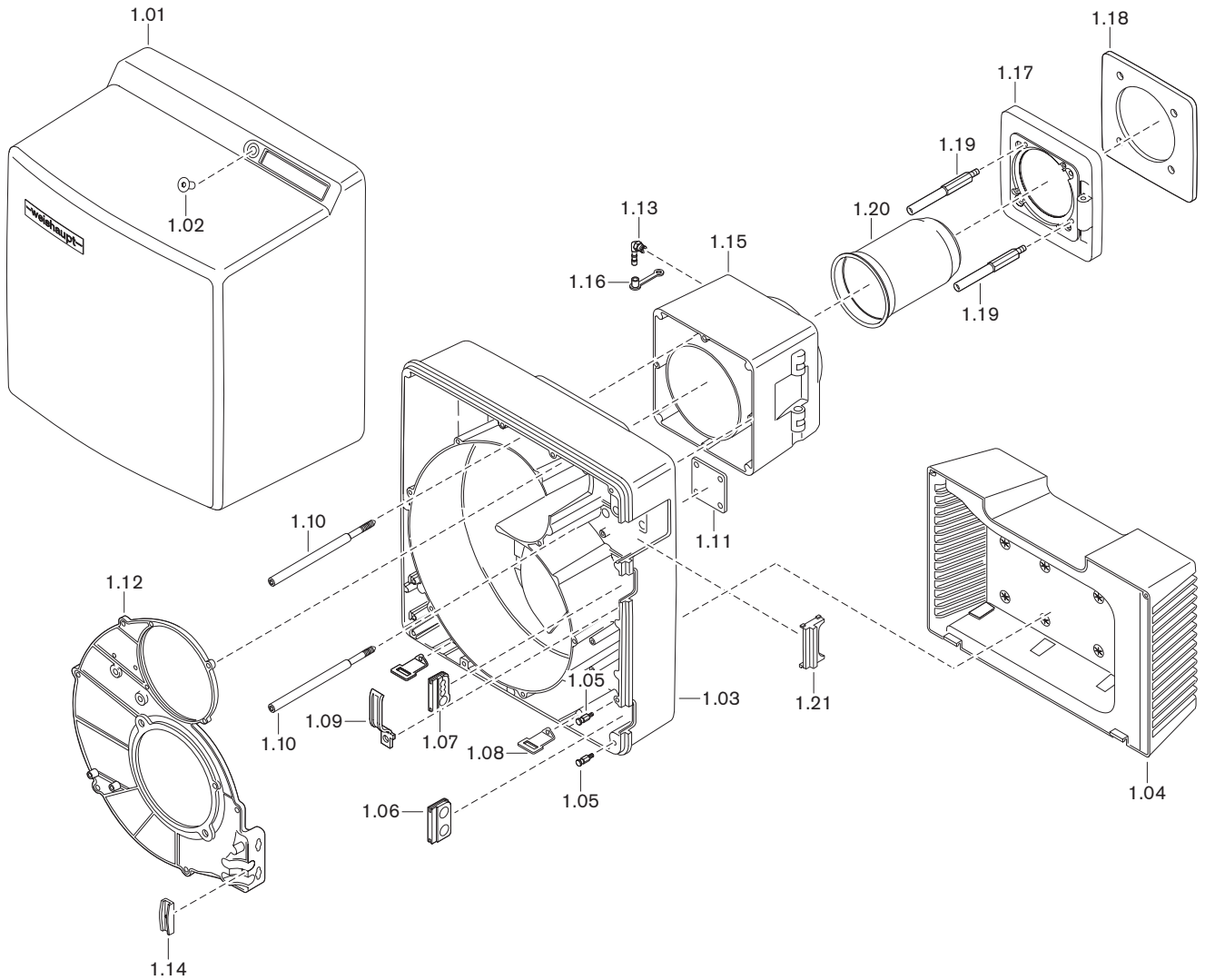

Pos.	Description	Order No.
1.01	Cover	241 400 01 112
1.02	Screw M8 x 16 DIN 7991	404 412
1.03	Burner housing	241 400 01 447
1.04	Intake housing complete	241 400 01 082
	– Screw 4 x 22 Torx-Plus Remform	409 307
1.05	Hanging bolt	241 400 01 327
1.06	Grommet	241 400 01 177
1.07	Grommet for connection cable	241 200 01 247
1.08	Mounting bracket for cover	241 400 01 207
1.09	Clamp	241 400 01 357
1.10	Screw M8 burner housing	241 400 01 257
1.11	Fixing plate for gas butterfly valve	232 400 01 057
1.12	Housing cover	241 400 01 457
1.13	Threaded socket R $\frac{1}{8}$ WES6	453 010
1.14	Bracket for cable	241 400 01 367
1.15	Intermediate flange	241 400 01 427
1.16	Protective cap DN 6 SELF 50/2 CF	232 300 01 047
1.17	Burner flange	241 400 01 437
	– Screw M10 x 35 DIN 912	402 600
	– Washer A10.5 DIN 125 A4	430 603
1.18	Flange gasket 8 x 238.5 x 238.5	241 400 01 147
1.19	Stay bolt M10 x 120 burner flange	241 400 01 247
1.20	Flame tube WG40	
	– Standard	232 400 14 142
	– extended by 100 mm*	230 400 14 032
	– extended by 200 mm*	230 400 14 152
	– extended by 300 mm*	230 400 14 112
	– Screw M5 x 12 Combi-Torx-Plus 20IP	409 247
	– Washer 5.5 x 12 oval	241 400 14 077
1.21	Cover burner housing	232 400 01 067

* Only in conjunction with combustion head extension.

13 Spares

Burner without variable speed drive

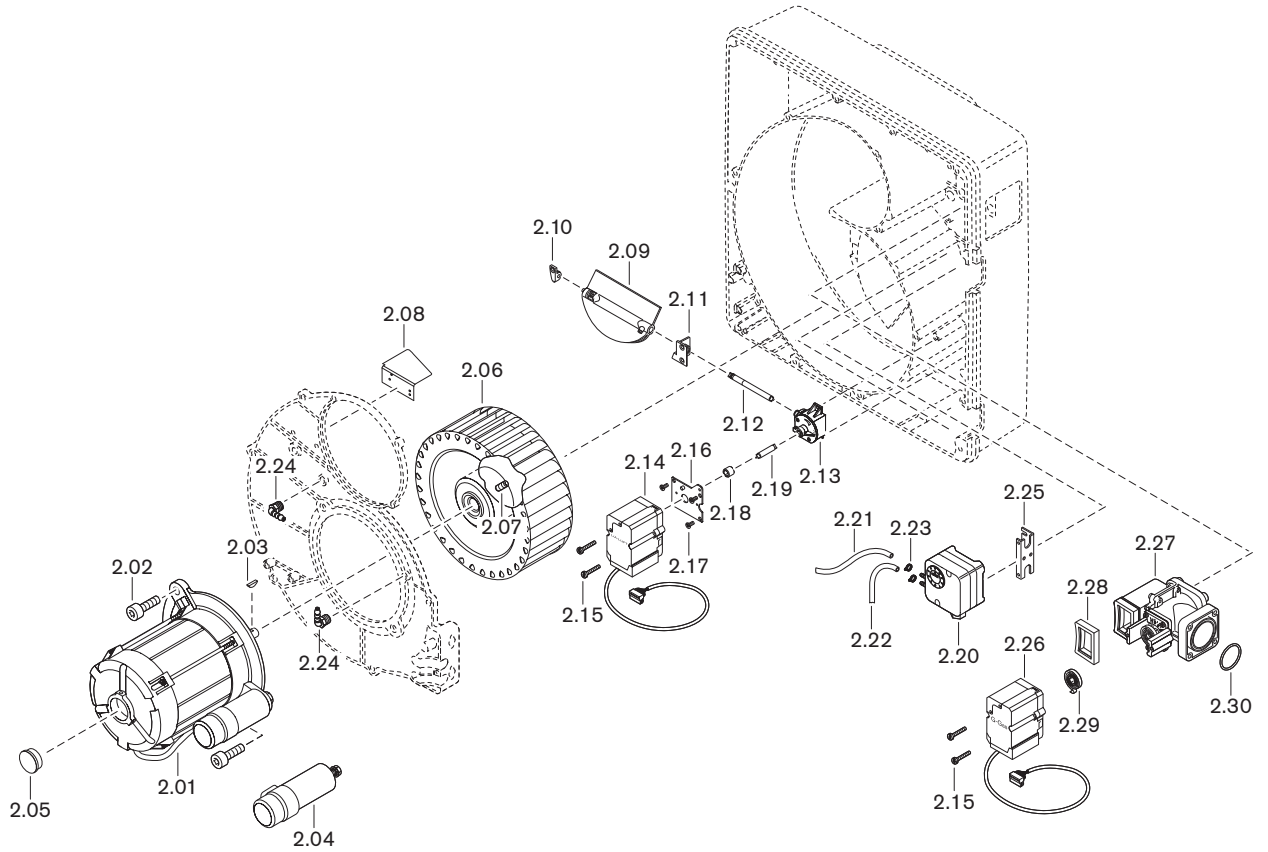

Pos.	Description	Order No.
2.01	Motor ECK06/A-2 230 V / 50 Hz	240 400 07 032
2.02	Screw M8 x 20 DIN 912	402 511
2.03	Shaft key 4 x 5 DIN 6888	490 154
2.04	Capacitor set 16.0 µF 420 V	713 479
2.05	Plug GPN 900 A 32 PHT black	446 108
2.06	Fan wheel TLR-S 190 x 81.8-L S1 50-60 Hz	241 400 08 032
2.07	Grub screw M8 x 8 w. an. cutter (Tuflok)	420 550
2.08	Air guide	232 400 01 047
2.09	Air damper complete	241 400 02 012
2.10	Bearing left	241 400 02 037
2.11	Bearing right with bearing bush	241 210 02 032
2.12	Shaft air damper - angle drive	241 400 02 147
2.13	Angle drive	241 110 02 062
2.14	Air actuator STE 4.5 24 V	651 103
2.15	Screw M4 x 30 Torx-Plus metric	409 245
2.16	Fixing plate	241 400 02 222
2.17	Screw M4 x 10 Torx-Plus 20IP	409 236
2.18	Guide sleeve	241 400 02 207
2.19	Shaft angle drive - actuator	241 400 02 157
2.20	Pressure switch LGW 10 A2 1 - 10 mbar	691 370
2.21	Hose 4.0 x 1.75 250 mm	232 110 24 037
2.22	Hose 4.0 x 1.75 140 mm	232 050 24 047
2.23	Hose clamp 7.5	790 218
2.24	Threaded socket R $\frac{1}{8}$ WES4	453 003
2.25	Pressure switch bracket	230 200 24 017
2.26	Gas actuator STE 4.5 24 V	651 101
2.27	Gas butterfly valve	232 400 25 020
2.28	Seal for connection channel	232 400 25 087
2.29	Torsion spring 2 heavy duty version	241 400 02 167
2.30	O ring 45 x 3 NBR70 ISO 3601	445 518

13 Spares

Burner with variable speed drive

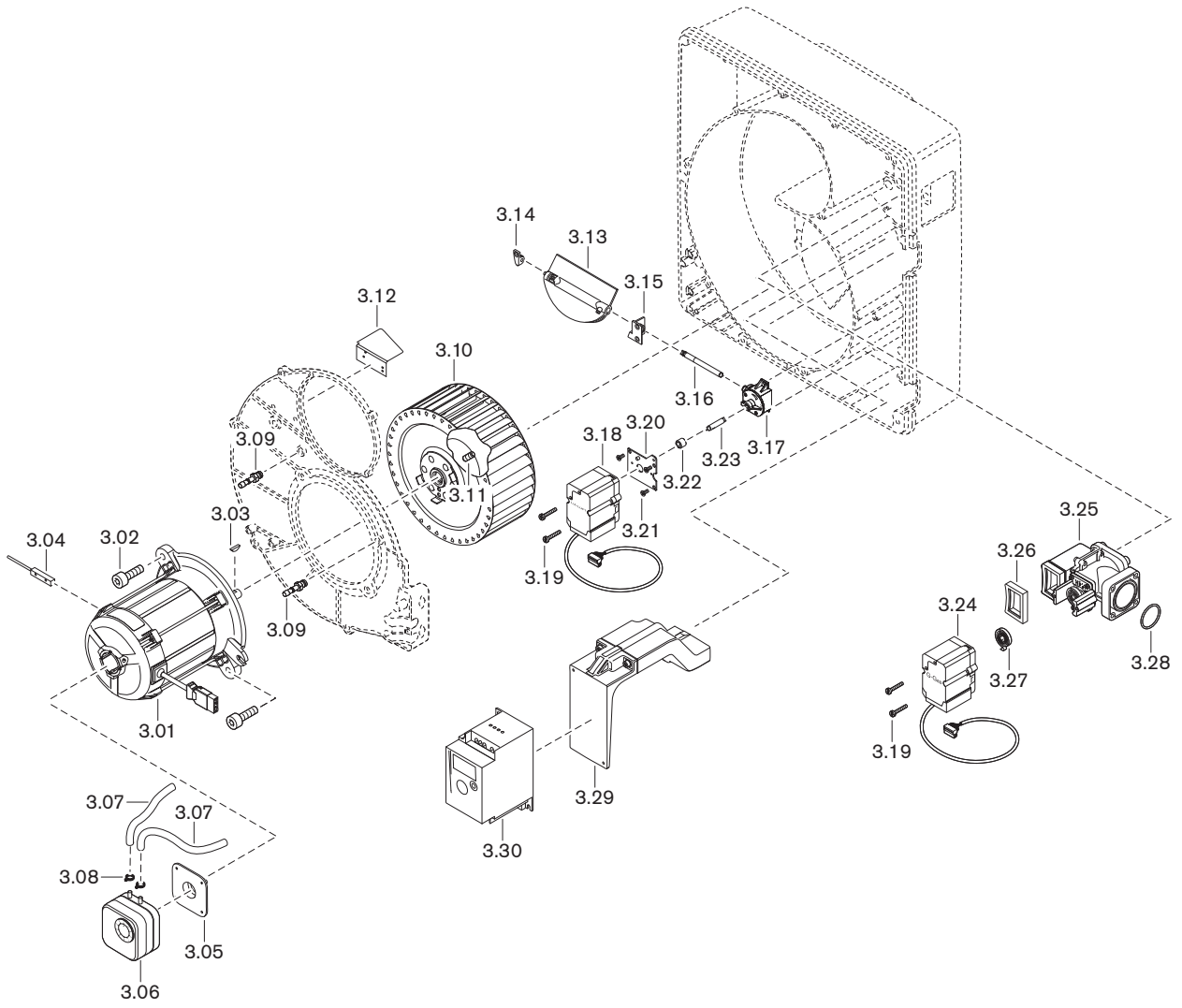

Pos.	Description	Order No.
3.01	Motor DK06A-2 3~ 230 V / 50 Hz	652 026
3.02	Screw M8 x 20 DIN 912	402 511
3.03	Shaft key 4 x 5 DIN 6888	490 154
3.04	Speed sensor KJ1.5-Q8MB40-NA-X complete	230 310 12 552
3.05	Connection flange for LGW	605 243
3.06	Pressure switch LGW 10 A2 1 - 10 mbar	691 370
3.07	Hose 4.0 x 1.75 250 mm	232 110 24 037
3.08	Hose clamp 7.5	790 218
3.09	Threaded socket R $\frac{1}{8}$ GES4	453 004
3.10	Fan wheel VSD TLR-S 190 x 81.8-L S1	230 400 08 012
3.11	Grub screw M8 x 8 w. an. cutter (Tuflok)	420 550
3.12	Air guide	232 400 01 047
3.13	Air damper complete	241 400 02 012
3.14	Bearing left	241 400 02 037
3.15	Bearing right with bearing bush	241 210 02 032
3.16	Shaft air damper - angle drive	241 400 02 147
3.17	Angle drive	241 110 02 062
3.18	Air actuator STE 4.5 24 V	651 103
3.19	Screw M4 x 30 Torx-Plus metric	409 245
3.20	Fixing plate	241 400 02 222
3.21	Screw M4 x 10 Combi-Torx-Plus counter-sunk	409 242
3.22	Guide sleeve	241 400 02 207
3.23	Shaft angle drive - actuator	241 400 02 157
3.24	Gas actuator STE 4.5 24 V	651 101
3.25	Gas butterfly valve	232 400 25 020
3.26	Seal for connection channel	232 400 25 087
3.27	Torsion spring 2 heavy duty version	241 400 02 167
3.28	O ring 45 x 3 NBR70 ISO 3601	445 518
3.29	Bracket complete for frequency converter	230 310 01 072
3.30	Frequency converter ATV 12	710 603

13 Spares

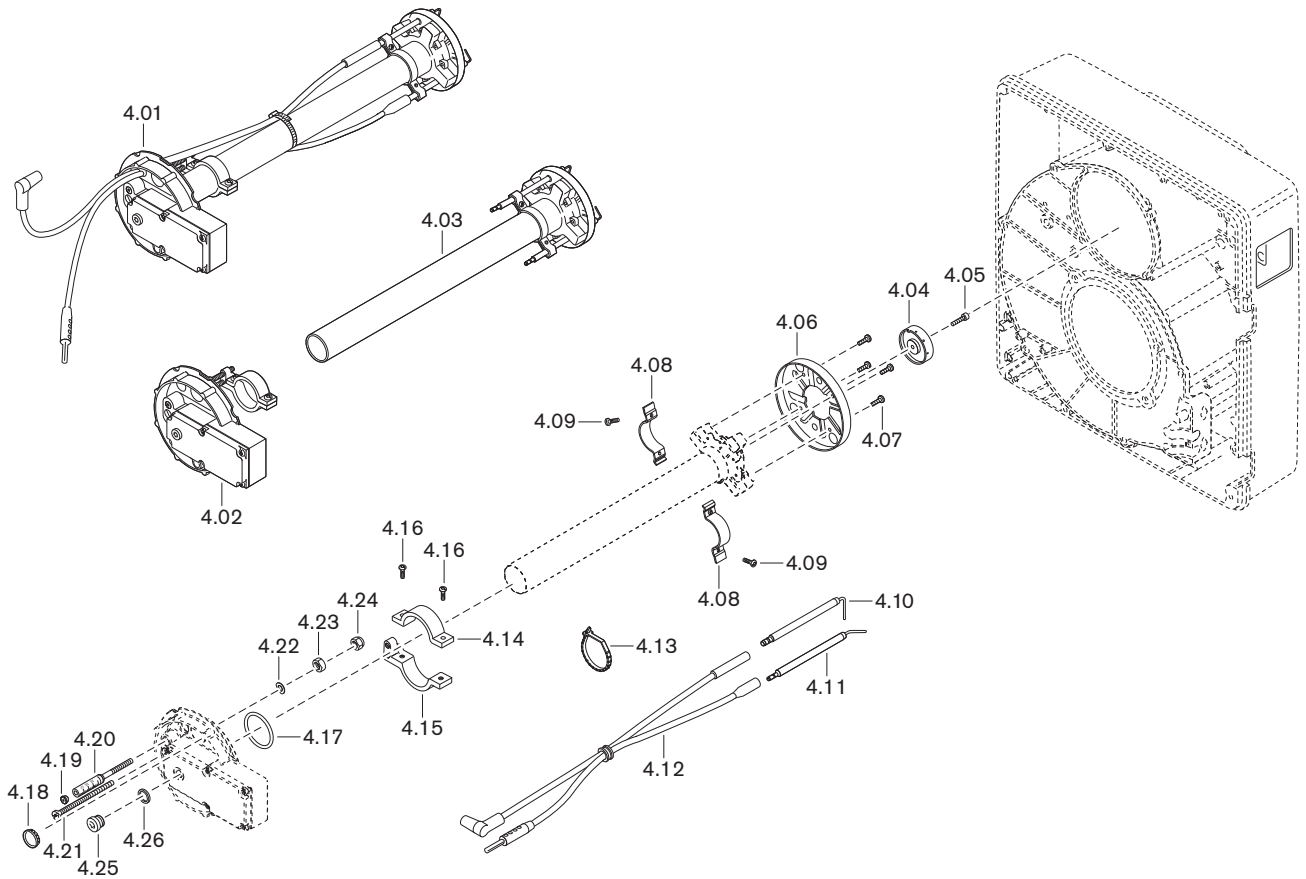

Pos.	Description	Order No.
4.01	Mixing head WG40N/1-A cpl. (Natural Gas)	
	– Standard	232 400 14 052
	– extended by 100 mm*	230 400 14 022
	– extended by 200 mm*	230 400 14 132
	– extended by 300 mm*	230 400 14 072
	Mixing head WG40F/1-A cpl. (LPG)	
	– Standard	233 400 14 012
	– extended by 100 mm*	230 400 14 172
	– extended by 200 mm*	230 400 14 192
	– extended by 300 mm*	230 400 14 212
4.02	Lock housing complete	232 400 14 022
4.03	Mixing tube WG40N/1-A cpl. (Natural Gas)	
	Ø internal 42 mm	
	– Standard	232 400 14 082
	– extended by 100 mm*	230 400 14 012
	– extended by 200 mm*	230 400 14 142
	– extended by 300 mm*	230 400 14 082
	Mixing tube WG40F/1-A cpl. (LPG)	
	Ø internal 28 mm	
	– Standard	233 400 14 022
	– extended by 100 mm*	230 400 14 182
	– extended by 200 mm*	230 400 14 202
	– extended by 300 mm*	230 400 14 222
4.04	Nozzle element	232 400 14 167
4.05	Screw M4 x 22 Torx-Plus 20IP	409 238
4.06	Diffuser 120 x 41	232 400 14 157
4.07	Screw M4 x 8 Torx-Plus 20IP	409 235
4.08	Bracket for electrodes	232 400 14 187
4.09	Screw M4 x 10 Torx-Plus 20IP	409 236
4.10	Ignition electrode	232 200 14 217
4.11	Sensor electrode	232 100 14 207
4.12	Ignition and sensor cable	
	– 700 mm (Standard)	232 400 11 042
	– 800mm (for 100 mm extension)*	230 310 11 182
	– 900mm (for 200 mm extension)*	230 310 11 192
	– 1100mm (for 300 mm extension)*	230 310 11 202
4.13	Re-opening belt 4.7 x 200 KBLS20045 sw	794 089
4.14	Adjusting lever top part	241 400 10 077
4.15	Adjusting lever bottom part	232 400 14 197
4.16	Screw M4 x 12 Torx-Plus 20IP	409 237
4.17	O ring 42 x 3 NBR70 ISO 3601	445 128
4.18	View port glass	241 400 01 377
4.19	Plug 5.25	241 110 10 087
4.20	Indicating bolt M6 x 90	241 110 10 097

* Only in conjunction with combustion head extension.

13 Spares

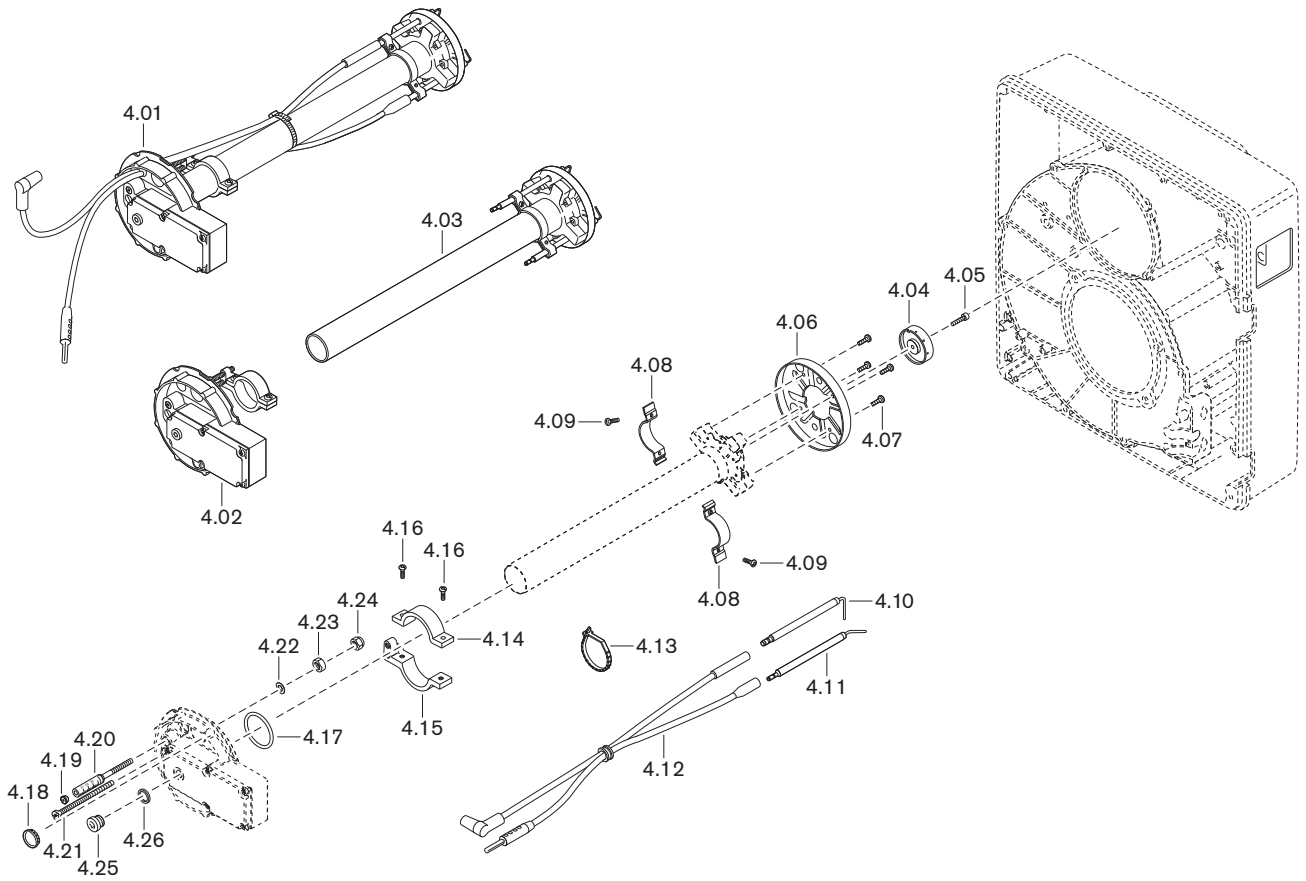

Pos.	Description	Order No.
4.21	Adjusting screw M6 x 88	241 400 10 097
4.22	Spring washer A6 DIN 137	431 615
4.23	Hexagonal nut M6 DIN 934 -8	411 301
4.24	Hexagonal nut M6 DIN 985 -6	411 302
4.25	Screw G $\frac{1}{8}$ A DIN 908 St	409 004
4.26	Sealing ring 10 x 13.5 x 1.5 DIN 7603	441 033

* Only in conjunction with combustion head extension.

13 Spares

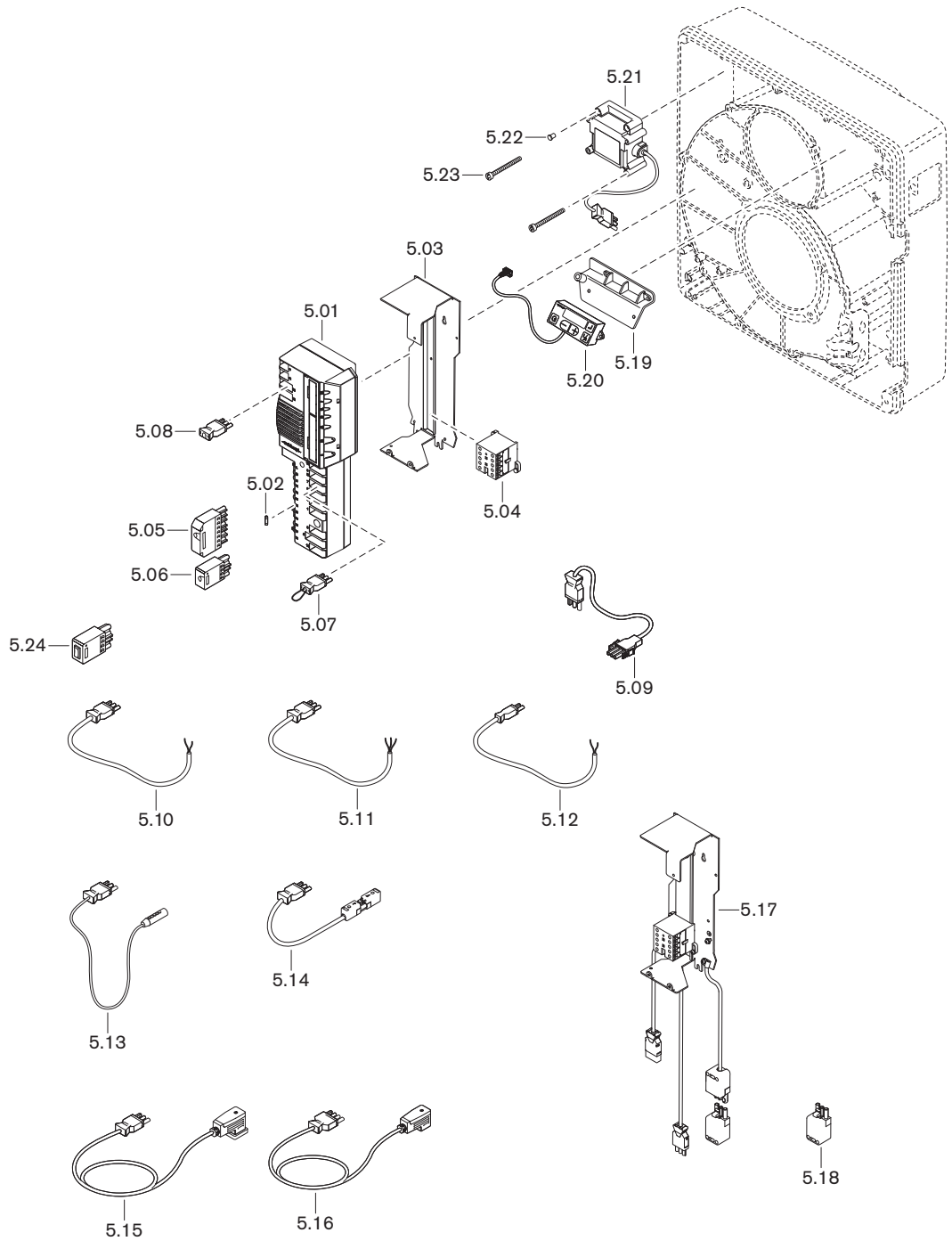

Pos.	Description	Order No.
5.01	Combustion manager W-FM 25 / 230 V	
	– intermittent operation without O ₂ trim	600 487
	– intermittent operation with O ₂ trim	600 491
	– continuous operation (PO-O ₂)	600 489
5.02	Micro fuse T6.3H, IEC 127-2/5	483 011 22 457
5.03	Bracket with carrier rail	232 310 12 022
5.04	Contactora B 7-30-10 220-240V	702 818
5.05	Plug unit ST18/7	716 549
5.06	Plug unit ST18/4	716 546
5.07	Bridging plug No. 7	241 400 12 042
5.08	Bridging plug No. 15	232 110 12 082
5.09	Plug cable No. 3 motor	241 050 12 062
5.10	Plug cable No. 3/N frequency converter	230 310 12 122
5.11	Plug cable No. 3 motor supply (VSD)	230 310 12 142
5.12	Plug cable No. 11 air pressure switch	232 400 12 032
5.13	Ionisation cable No. 13	232 310 12 012
5.14	Plug cable No. 14 remote reset	230 110 12 362
5.15	Plug cable No.12 gas pressure switch	232 400 12 022
5.16	Plug cable No. 5 W-FM, DMV	232 400 12 012
5.17	Contactora 230 V with bracket	230 310 12 512
5.18	Plug unit ST18/3	716 543
5.19	Fixing bracket	241 400 12 017
5.20	ABE for W-FM 20 / 25 with 0.58 m cable	600 481
5.21	Ignition unit type W-ZG01V 230 V 100 VA	603 221
5.22	Closing plug for ignition unit	603 135
5.23	Screw M4 x 42 Combi-Torx-Plus 20IP	409 260
5.24	Plug-in switch ST18/4	130 103 15 012

13 Spares

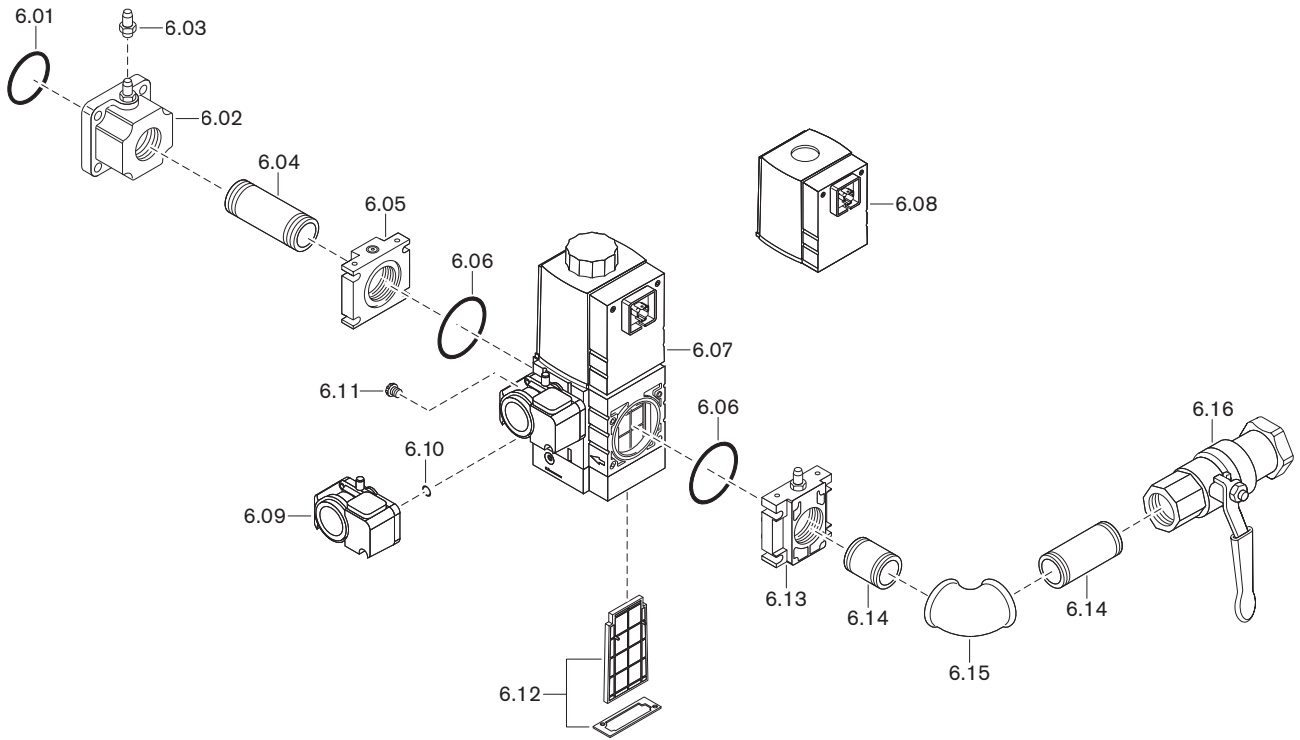

Pos.	Description	Order No.
6.01	O ring 45 x 3 NBR 70, DIN 3771	445 518
6.02	Flange Rp1½	232 400 26 027
6.03	Pressure test nipple G ¹ / ₈ A	453 001
6.04	Double nipple R1½ x 80	139 000 26 677
6.05	Flange	
	– DMV 507 Rp1½	605 234
	– DMV 512 Rp1½	605 230
6.06	O ring	
	– 57 x 3 W-MF 507	445 519
	– 75 x 3.5 W-MF 512	445 520
6.07	Multifunction assembly with gas pressure switch	
	– W-MF SE 507 S22 230 V	605 320
	– W-MF SE 512 S22 230 V	605 321
6.08	Solenoid coil	
	– W-MF 507 No. 032P 230 V	605 255
	– W-MF 512 No. 042P 230 V	605 257
6.09	Pressure switch GW 50 A5/1 5 ... 50 mbar with screws and O ring	691 378
6.10	O ring 10.5 x 2.25 for pressure switch	445 512
6.11	Breather plug with filter element G ¹ / ₈	605 302
6.12	Filter insert	
	– W-MF 507	605 253
	– W-MF 512	605 254
6.13	Flange with pressure test nipple	
	– DMV 507 Rp¾	232 110 26 092
	– DMV 512 Rp1	232 210 26 252
	– DMV 512 Rp1½	232 310 26 062
6.14	Double nipple	
	– R¾ x 50	139 000 26 117
	– R¾ x 100	139 000 26 627
	– R1 x 50	139 000 26 177
	– R1 x 100	139 000 26 187
	– R1½ x 80	139 000 26 677
	– R1½ x 120	139 000 26 237
6.15	Elbow A1	
	– ¾-Zn-A	453 143
	– 1-Zn-A	453 123
	– 1½-Zn-A	453 137
6.16	Isolating valve with TAE	
	– 998NG-¾-CE-TAS for Gas PN1	454 596
	– 998NG-1-CE-TAS for Gas PN1	454 597
	– 984 1½-CE-TAS MOP5	454 911
	Isolating valve without TAE	
	– 984D-¾ PN 40/MOP5	454 660
	– 984D-1 PN 40/MOP5	454 661
	– 984D-1½ PN 40/MOP5	454 663

13 Spares

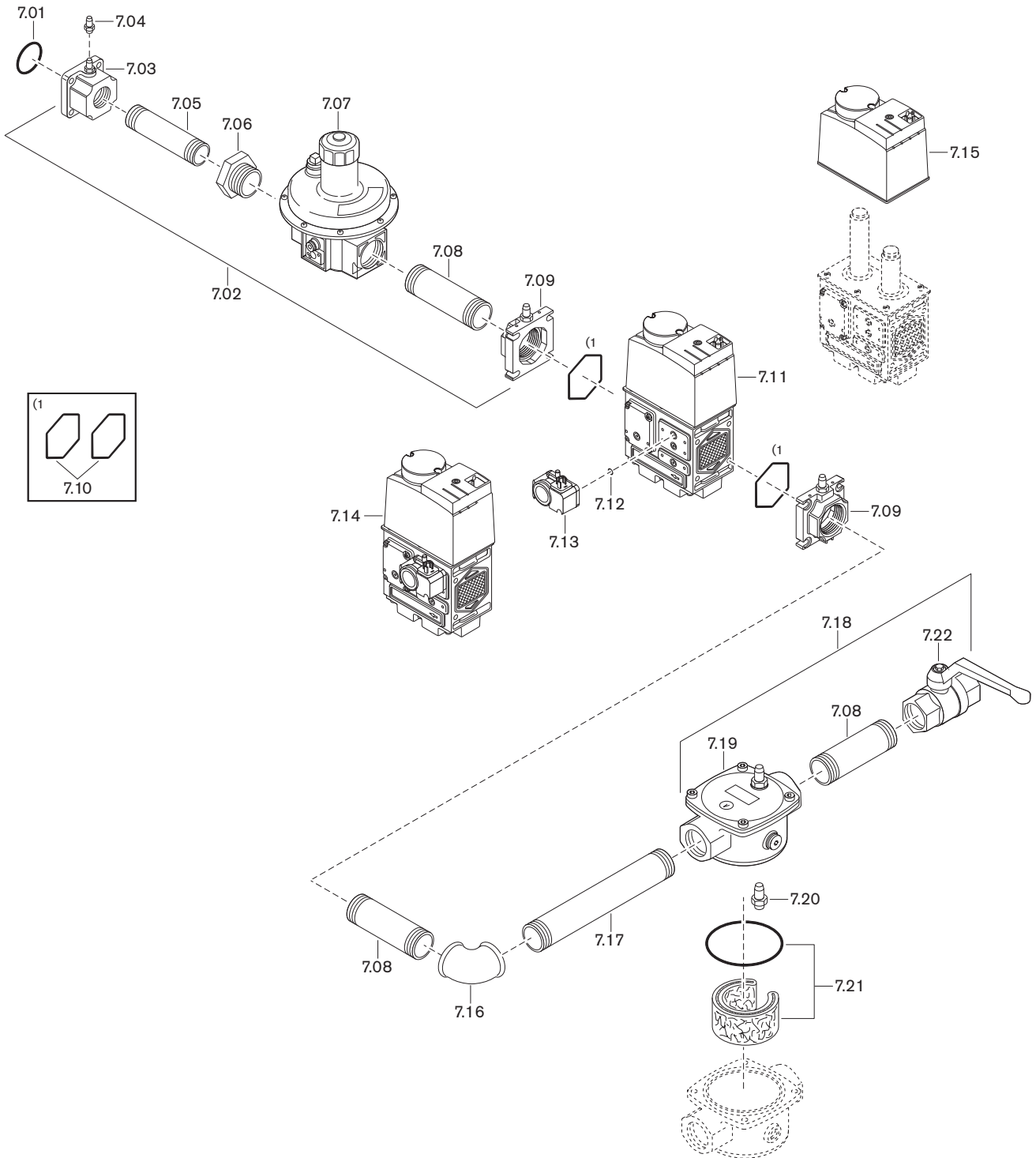

Pos.	Description	Order No.
7.01	O ring 45 x 3 NBR 70, DIN 3771	445 518
7.02	Valve train gr. press. reg. R2 DMV 525/12	232 400 26 252
7.03	Flange Rp1½	232 400 26 027
7.04	Pressure test nipple G ¹ / ₈ A	453 001
7.05	Double nipple R1½ x 80	139 000 26 677
7.06	Nipple N4-2 x 1½ Zn-A EN10242	453 718
7.07	Pressure regulator FRS 520-2S Rp2	640 553
7.08	Double nipple R2 x 80	139 000 26 267
7.09	Flange w. p. test nipple Rp2 DMV 525/12	625 031
7.10	Gasket set for flange DMV 525/12	625 033
7.11	Solenoid valve DMV 525/12 220-240 V	625 040
7.12	O ring 10.5 x 2.25 for pressure switch	445 512
7.13	Pressure switch GW 50 A5/1, 5-50 mbar	691 378
7.14	Valve train group DMV 525 R2 w. GW 230 V	232 400 26 242
7.15	Solenoid coil DMV 525/12 220-240 V	625 022
7.16	Elbow A1-2 Zn-A EN10242	453 112
7.17	Double nipple R2 x160	139 000 26 277
7.18	Valve train group filter R2	230 310 26 132
7.19	Filter RP2 WF 520/1 for all gases PB	151 223 40 160
7.20	Pressure test nipple G ¹ / ₄ A	453 005
7.21	Filter insert set WF 520/1	151 334 26 112
7.22	Isolating valve with TAE	
	– 984 2 -CE-TAS MOP5	454 912
	Isolating valve without TAE	
	– 984D-2 PN 40/MOP5	454 664

13 Spares

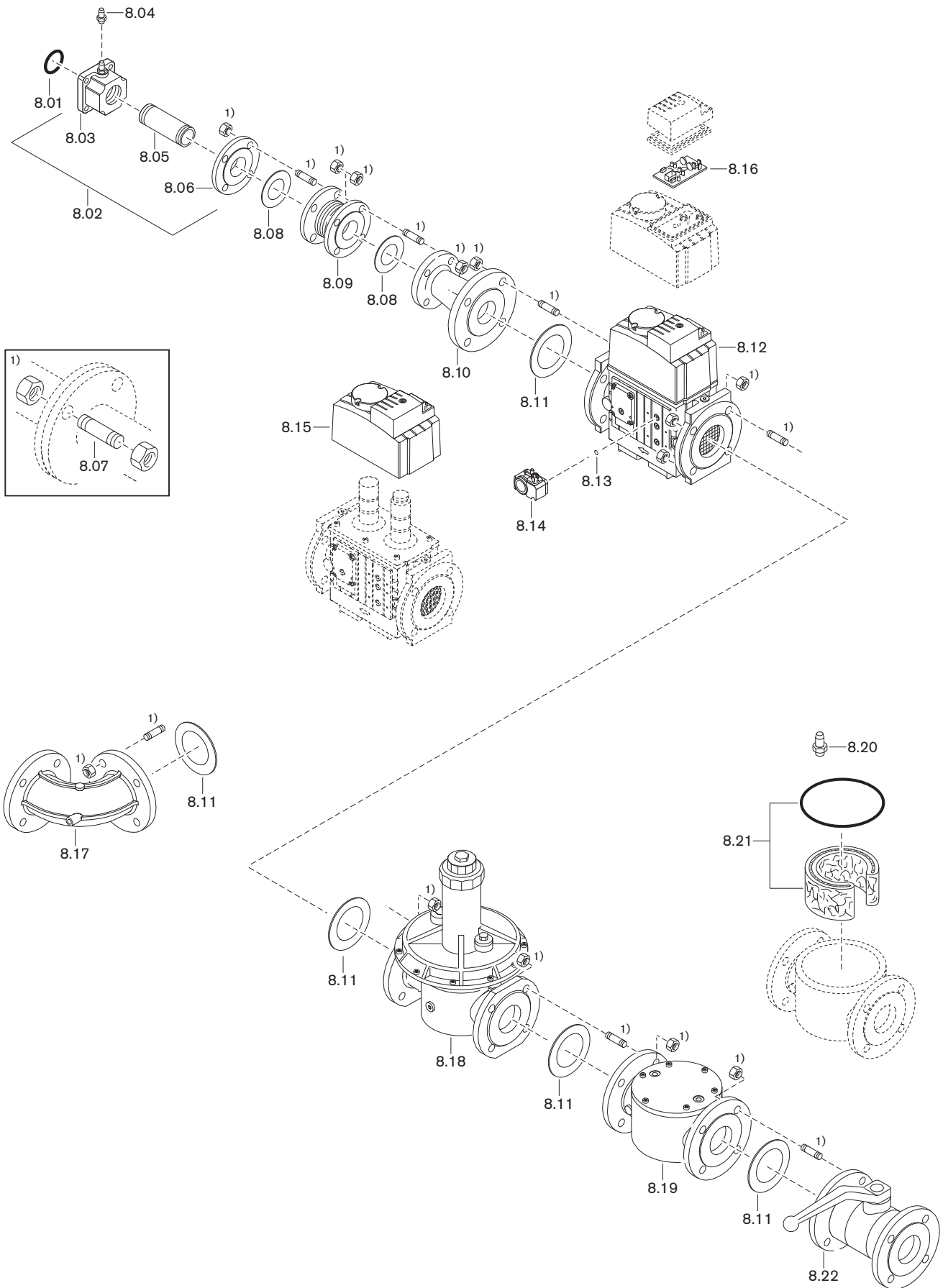

Pos.	Description	Order No.
8.01	O ring 45 x 3 NBR 70, DIN 3771	445 518
8.02	Valve train flange DN 40	232 400 26 212
8.03	Flange Rp1½	232 400 26 027
8.04	Pressure test nipple G ¹ / ₈ A	453 001
8.05	Double nipple R1½ x 80	139 000 26 677
8.06	Screwed flange Rp1½ St37 C40, DIN 2566	452 920
8.07	Stud screw M16Fo v 50 DIN 939 5.6	421 057
	– hexagonal nut M16 DIN 934 -8	411 801
8.08	Sealing ring 49 x 92 x 2 EN 1514-1	441 859
8.09	Compensator DN 40, PN 10, length 97 mm	454 342
8.10	Reducing flange eccentric	
	– DMV 5065/12, 40/65	151 327 26 517
	– DMV 5080/12, 40/80	151 327 26 737
8.11	Sealing ring EN 1514-1	
	– DMV 5065/12, 77 x 127 x 2	441 861
	– DMV 5080/12, 90 x 142 x 2	441 044
8.12	Solenoid valve	
	– DMV 5065/12 220-240 V	625 007
	– DMV 5080/12 220-240 V	625 009
8.13	O ring 10.5 x 2.25 for pressure switch	445 512
8.14	Pressure switch GW 50 A5/1, 5-50 mbar	691 378
8.15	Solenoid coil	
	– DMV 5065/12 220-240 V	625 024
	– DMV 5080/12 220-240 V	625 026
8.16	Circuit board DMV 5065/12, 5080/12 220-240	605 989
8.17	Flange elbow	
	– DN 65 x 90 DEG	151 327 26 342
	– DN 80 x 90 DEG	151 327 26 362
8.18	Pressure regulator	
	– FRS 5065 DN 65	640 672
	– FRS 5080 DN 80	640 673
8.19	Filter WF 3065/1 for all gases PB	
	– DN 65	151 223 40 190
	– DN 80	151 223 40 200
8.20	Pressure test nipple G ¹ / ₄ A	453 005
8.21	Filter insert set	
	– WF 3065/1	151 334 26 152
	– WF 3080/1	151 334 26 162
8.22	Isolating valve without TAE	
	– DN 65 PN16 for Gas	454 640
	– DN 80 PN16 for Gas	454 641

14 Notes

14 Notes

A	
Access level	31, 37
Actuator.....	79
Adjustment	68
Air damper	11, 48, 79
Air damper setting post-purge.....	36
Air number	66
Air pressure.....	67
Air pressure switch.....	11, 65
Ambient conditions.....	18
Ammeter.....	40
Analogue module	35
Angle drive.....	80
Aperture	21, 22, 23
Appliance category.....	100
Approval data.....	18
B	
Bar	100
Basic setting	74
Boiler room.....	7
Booming.....	97
Breaks in operation.....	69
Breather plug	83
Burner motor	14, 78
Burner starts	33
C	
Calculation.....	54, 62
Calorific value	46
Capacity	19
Capacity graph	19
CO content	66
Coil.....	82
Combustion air	7
Combustion chamber pressure.....	19
Combustion control.....	66
Combustion head	19
Combustion head extension.....	21
Combustion heat rating.....	19, 48
Combustion limit	66
Combustion manager	14, 86
Combustion settings.....	68
Commissioning.....	39
Condensate.....	8
Connection.....	15
Connection pressure	24, 41, 46
Consumption.....	18
Contactora.....	29
Control unit.....	86
Conversion factor	67
Conversion table.....	100
Corrections.....	68
Current measuring device.....	40
D	
Design lifespan	7, 70
Detailed fault codes	92
Device fuse.....	89
Diffuser.....	11, 48, 49
Dimensions.....	20
Display.....	30, 32
Display and operating unit	30
Disposal	8
Double gas valve.....	12, 24
Drilling diagram.....	21
Ducted air intake	7, 19
E	
Electrical connection.....	28
Electrical data	18
Electrode.....	75
Emission.....	18
Emission class	18
Excess air.....	66
F	
F1.....	32
F9.....	32
Fabrication number.....	10
Fan motor.....	78
Fan pressure	40
Fan wheel.....	11, 77
Fault	90, 97
Fault codes.....	93
Fault memory.....	34, 91
Faults	93
Fieldbus.....	15, 33
Fieldbus module.....	35
Filter	84, 85
Filter insert.....	84, 85
Flame signal	14, 30, 40
Flame tube.....	21
Flue gas losses.....	66
Flue gas measurement.....	66
Flue gas temperature	66
Frequency converter	14
Fuel.....	18
Full load.....	53, 60
Fuse	89
Fusing	15, 18
G	
Gas butterfly valve	12
Gas connection pressure.....	24, 41
Gas consumption.....	33
Gas family	100
Gas filter.....	12, 84, 85
Gas isolating valve.....	12
Gas meter.....	33
Gas pressure switch	12, 27
Gas setting pressure.....	46
Gas supply	24
Gas temperature	67
Gas throughput	67
Gas valve train	22, 24, 25, 46
Guarantee.....	6

15 Key word index

H	
Heat exchanger	21
High gas pressure switch	13, 64
Hours run	33
Housing cover.....	76
hPa	100
Humidity	18
I	
Ignition electrode	75
Ignition speed	61
Ignition unit	14
Indicating bolt	49, 74
Info key	30
Info level	33
Initialisation time	17
Inputs	15
Installation.....	21, 22
Installation elevation	19
Installation location	21
Installation position	24
Interface	15
Ionisation current.....	40
Ionisation electrode	14, 75
Isolating valve.....	12
K	
kPa.....	100
L	
Liability.....	6
Lifespan.....	7, 70
Linearisation	54, 62
Lockout.....	90, 93
Low gas pressure switch/valve proving gas pressure switch.....	12, 64
M	
Mains voltage	18
Maintenance position.....	76
mbar	100
Measuring device.....	40
Minimum speed	61
Mixing head	11, 48, 73, 74
Mixing pressure	40
Monitoring current	40
Motor.....	14, 78
Motor contactor.....	29
MPa.....	100
Multifunction assembly	12
N	
Name plate	10
Noise.....	97
Nominal diameter	46
O	
OFF function	30
Operating level	30
Operating panel	14, 90
Operating problems	97
Operating status	31, 92, 98
Operating volume	67
Outputs	15
P	
Pa.....	100
Parameter level	35
Partial load.....	55, 63
Pascal	100
Post-purge time.....	17
Pre-purge time.....	17
Pressure measuring device	40
Pressure regulator	12, 24
Pressure switch.....	11, 65
Pressure switches	49
Program sequence	16, 98
Pulsating	97
R	
Refractory	21
Remote reset.....	28
Repetition counter	92
Reset.....	91
Reset key	30
S	
Safety measures.....	7
Safety time.....	17
Serial number.....	10
Service.....	70
Service contract	70
Service interval	70
Service level	34
Service plan.....	72
Service position.....	76
Setting diagram	48
Setting dimensions.....	74
Setting pressure.....	46
Setting screw.....	74
Shutdown	69
Shutdown time	69
Smell of gas	7
Software.....	31
Solenoid coil	82
Sound	18
Sound power level	18
Sound power levels.....	18
Sound pressure level	18
Soundness test	42
Spares	107
Speed standardisation.....	58
Stability problems	97
Standard volume	67
Standards	18
Starts	33
Sticker	88
Storage.....	18

T

Temperature 18
Test points 44
Test pressure 42
Transport 18
Troubleshooting 97
Type key 9
Type of gas 18, 100

U

Unit 100
Unit of pressure 100

V

Valve proving 12, 64
Valve train 25
Variable speed drive 14
Variable speed drive sensor 78
VisionBox 31
Voltage supply 18

W

Weight 20

The complete program: Reliable technology and prompt, professional service

	<p>W Burners up to 570 kW</p> <p>The compact burners, proven millions of times over, are economical and reliable. Available as gas, oil and dual fuel burners for domestic and commercial applications.</p> <p>The purflam® burner version with special mixing head gives almost soot-free combustion of oil with greatly reduced NOx emissions.</p>	<p>Wall-hung condensing boilers for gas up to 240 kW</p> <p>The wall-hung condensing boilers WTC-GW have been developed to meet the highest demands in ease of operation and efficiency. Modulating operation means these units operate quietly and economically.</p>	
	<p>monarch® WM Burners and Industrial Burners up to 11,700 kW</p> <p>These legendary industrial burners are durable and versatile. Numerous variations of oil, gas and dual fuel burners meet a wide range of applications and capacity requirements.</p>	<p>Floor-standing condensing boilers for oil and gas up to 1,200 kW</p> <p>The floor-standing condensing boilers WTC-GB (up to 300 kW) and WTC-OB (up to 45 kW) are efficient, low in pollutants and versatile in use. Even the largest capacities can be covered by cascading up to four gas condensing boilers.</p>	
	<p>WKmono 80 Burners up to 17,000 kW</p> <p>The WKmono 80 burners are the most powerful monoblock burners from Weishaupt. They are available as oil, gas or dual fuel burners and are designed for tough industrial application.</p>	<p>Solar systems</p> <p>The stylish flat-plate collectors are the ideal complement for any Weishaupt heating system. They are suitable for solar water heating and for combined heating support. With versions for on-roof, in-roof and flat roof installations, solar energy can be utilised on almost any roof.</p>	
	<p>WK Burners up to 32,000 kW</p> <p>These industrial burners of modular construction are adaptable, robust and powerful. Even on the toughest industrial applications these oil, gas and dual fuel burners operate reliably.</p>	<p>Water heaters/Energy storage</p> <p>The diverse program of potable water and energy storage for various heat sources includes storage volumes of 70 to 3,000 litres. In order to minimize storage losses, potable water cylinders from 140 to 500 litres are available with highly efficient insulation using vacuum insulation panels.</p>	
	<p>MCR Technology / Building Automation from Neuberger</p> <p>From control panels to complete building management systems - at Weishaupt you can find the entire spectrum of modern control technology. Future orientated, economical and flexible.</p>	<p>Heat pumps up to 180 kW</p> <p>The heat pump range offers solutions for the utilisation of heat from the air, the soil or ground water. Some systems are also suitable for cooling buildings.</p>	
	<p>Service</p> <p>Weishaupt customers can be assured that specialist knowledge and tools are available whenever they are needed. Our service engineers are fully qualified and have extensive product knowledge, be it for burners, heat pumps, condensing boilers or solar collectors.</p>	<p>Geothermal probe drilling</p> <p>With its daughter company, BauGrund Süd, Weishaupt also offers geothermal probe and well drilling. With the experience of more than 10,000 systems and more than 2 million meters of drilling, BauGrund Süd offers a comprehensive service program.</p>	