

Instruction Manual

(Digital Differential Pressure Switch & Transmitter)

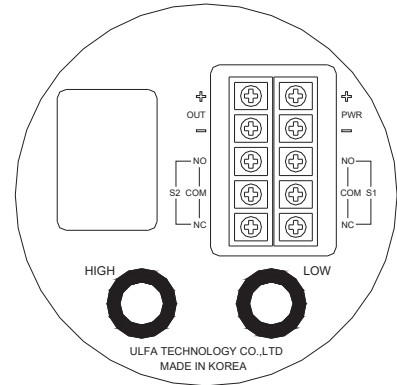

1. General Specification
2. Installation
3. Wiring
4. Function
5. Setting & Calibration

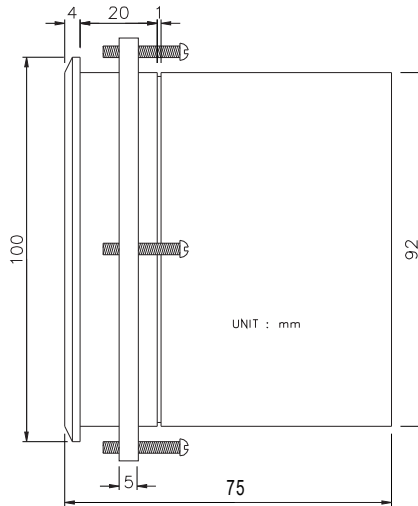

General

PIT/PDS Series pressure switch and transmitter are measures and controls positive, negative(vacuum) and differential pressure of air or non corrosive gases, and for the variously choice of ranges available to suit your needs precisely.

The PIT/PDS Widely used to measure fan and blower pressures, filter resistance, pressure drop across orifice plates, liquid levels in storage tanks and many other applications. The PIT model has three functions of gauge, switch and transmitter. And PDS has two functions of gauge and switch. PDS has two(2) SPDT relays for individual level control. It is very easy to set control level by front pad key.

Accuracy is +/-0.25% of full scale.

Range Table

Model No	Range	Resolution
-B15M	±15.0 mmH ₂ O	0.1 mmH ₂ O
-B150M	±150.0 mmH ₂ O	0.1 mmH ₂ O
-B1500M	±1500 mmH ₂ O	1 mmH ₂ O
-B760H	±760 mmHg	1 mmHg
-D30M	0~30.0 mmH ₂ O	0.1 mmH ₂ O
-D300M	0~300.0 mmH ₂ O	0.1 mmH ₂ O
-D3000M	0~3000 mmH ₂ O	1 mmH ₂ O
-B01K	±1.000 kg/cm ²	0.001 kg/cm ²
-B07K	±7.00 kg/cm ²	0.01 kg/cm ²

We can apply to other user specification (Pressure units and range)

Specification

GENERAL

Maximum Pressure:
Media Compatibility:
Pressure Range:

Rated Range x 3
Air and non corrosive gas
Refer to range table

ELECTRICAL

Power Supply:

DC24V(100-220VAC
50~60Hz)

Connections:

2 screw terminal block

Display:

4 Digit LED

Warm up Time:

15 minutes

SWITCH

Relay Contact:

2 SPDT(NC - COM - NO)

Contact Rating:

5A@240 VAC

Connections:

6 Screw terminal block

Level setting:

Individual level setting
Switch 1 & 2

TRANSMITTER(PIT)

Connections:

2 Screw terminal block

Output Signal:

4-20mADC(limited at
30mADC)

Loop Resistance:

0 - 1100Ω

Zero & Span Adj:

One touch Adjustable on
Panel

PERFORMANCE AT 23 °C(PIT)

Zero Output:

4 mA

Full Span Output:

20 mA

Accuracy:

±0.25 % FSO(Includes
Linearity, Hysteresis &
Repeatability)

Operating Temperature:

-10 to 70 °C

MECHANICAL

Pressure Connections:

1/8" PT female

Materials:

ABS Mold Resin

Weight

310g

STANDARD ACCESSORIES

Tow(2) 1/8" PT plugs for duplicate/ Snap ring
Mounting ring, four(4) mounting screws

Installation

LOCATION : Select your site location , Clean and dry, no shock and vibration, proper to the ambient temperature and humidity in use.

PANEL MOUNTING

The PIT/PDS Series Digital Pressure Switch & Transmitter is designed for panel mounting in a single 93mm diameter hole.

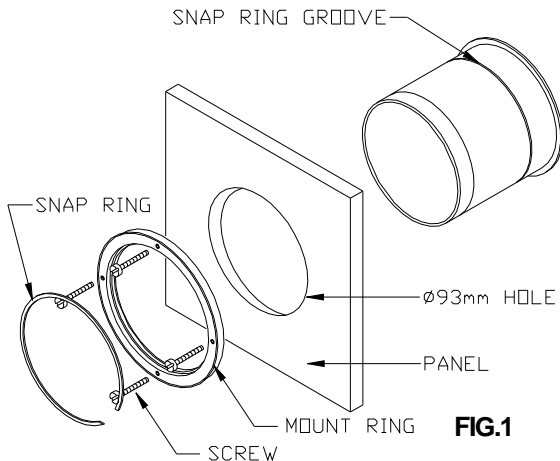

FIG.1

A panel mounting fastening kit is provided with all PIT/PDS Series Pressure Switch & Transmitter.

1. Select your site location, mark the appropriate panel cutout and complete the necessary panel cut.
2. Carefully insert the Pressure Switch & Transmitter through the hole from front of the panel.
3. Carefully insert the mount ring through the body of PIT/PDS from back side.
4. Insert the snap ring to the snap ring groove.
5. Tightening four mount screw through the mount ring from back side.

PRESSURE PORT CONNECTION

Two(2) PT 1/8" barbed nipples are provided with all PIT/PDS Series Pressure Switch & Transmitter

1. Wind teflon seal tape on the screw of the nipple and tightening it in the pressure port high and low
2. If you use the PIT/PDS to measure differential pressure, high pressure is connect to "HIGH" port, and low pressure is connect to "LOW" port.
3. If you use PIT/PDS to measure single pressure, positive pressure is connect to "HIGH" port and negative pressure(vacuum) is connect to "LOW" port. (In this case, another port is open to air)
4. Standard pressure connections are barbed fittings for 3/16" I.D. tubing.

Wiring

POWER CONNECTION

The following procedures are to be used to install a standard 24VDC main power source.

1. Before connection, the user must first confirm that the power specification is DC24V or AC220V.
2. Verify that the facility's main power source is turned off or disconnected.
3. Connect lead cable to power terminal matching polarity as shown in FIG.2 below. Take care that wrong wiring will damage the Instrument and malfunction (AC220V is not concerned to polarity)

CURRENT OUT CONNECTION(4-20mA)(PIT only)

The PIT sends a standard 2 wire 4-20mA current out

1. Connect lead cable to current out terminal matching polarity as shown in FIG.2 below.
2. Do not run the signal cable along with any high voltage or power cable or put them in the same race way. It may cause malfunction due to induction.

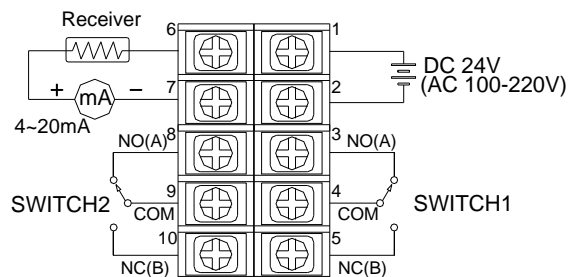

FIG.2

SWITCH OUT CONNECTION

PIT/PDS has two switches output. Each switch operate individually and has A(normal open) and B(normal close) contacts.

Caution : Do not use heavy load drive directly over the switch contact rating.

Switch contact rating(resist load)

Normal Switching Capacity	5 A @ 240 VAC
Max Switching Power	1.2 KW
Max Switching Voltage	240 VAC
Max Switching Current	5 A

Function

Zero setting : Optimize display and current out to zero automatically by front key pressed.

Peak pressure Measurement : This mode is display for peak pressure by supplied pressure. And the display is cleared by press enter key in the peak mode.

Offset(p) pressure Measurement : This mode is display the changed pressure based on the current pressure. Current pressure is turned into "0" when offset mode selected. This mode does not concern to 4-20mA current out put.

Sampling time setting : Sample rate is 0.1sec of this product. Sampling time is measuring time by sample rate. For example, if setting time is 2 sec, PIT/PDS measures 20 times for 2 seconds and out to display and 4-20mA out put by average of 20 times measured value.

Switch : PIT/PDS has two switches output. Each switch operate individually and has A(normal open) and B(normal close) contacts.

Transmitter(PIT) : PIT has 4-20mA current out put. Span (20mA) range can be changed within original range.

Communication(option) : Measurement pressure can be sent by RS232 or RS485 for option specification.

ID setting : This mode set identification number for communication.

Over pressure warning : PIT/PDS displays warning on segment for over pressure (positive and negative). Upper 4 elements of 7segment("— — — —") blink for warning when measurement pressure over 10% for high pressure(factory setting value), And under 4 elements of 7segment("_ _ _ _") blink for warning when measurement pressure under 10% for low pressure(factory setting value),

Factory setting recovery : The parameters are changed all to factory setting value and all user setting value is cleared.

Setting and Calibration

Hear by describe key function and setting methode. Please read this section carefully for the correct and optimum use of this product.

Key functions

	UP	- Increase setting value - Offset mode set/reset
	DOWN	- Decrease setting value - Peak pressure mode set/reset
	MODE	- Entering into the setting mode - Setting item circulation
	ENTER	- Save setting value - Clear peak value in the peak mode - Release setting mode

Peak mode

Press the PEAK(down) key once to set peak mode

"PEA" displayed like left while press peak key

Press the ENTER to reset peak value and newly start

Press the PEAK(down) key once more to release peak mode

Offset mode

Press the P(UP) key once to set offset mode

"dELt" displayed like left while press P key

Press the P(UP) key once more to release offset mode

Switch level setting

Press the MODE key once to change switch setting level. The setting mode circulate <SW1 OFF SW1 ON SW2 OFF SW2 ON> when mode key press repeated. Switches can be use to below two type by level setting.

(1) Hysteresis mode

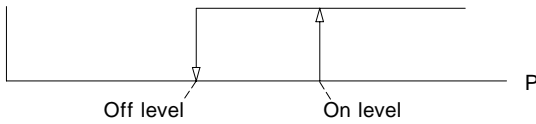

(2) Window mode

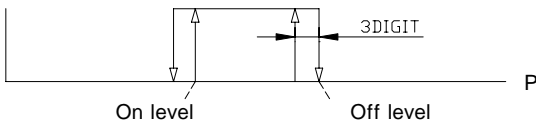

CAUTION:

On level = Off level : switch off
It is necessary to differ On level and Off level above 4digits.

SWITCH1 OFF LEVEL

Press MODE key once to set sw1-off level. S1 LED is on while into the sw1-off level setting mode

1oFF

"1oFF" displayed like left while press mode key in the sw1-off level setting mode

Set your switch level use up/down key

Press ENTER once to save and exit to measure mode. Press ENTER for more than 3 seconds to save and exist in the switch level setting mode

SWITCH1 ON LEVEL

Press MODE key to select sw1-on level set mode. S1, P LED is on while into the sw1-on level setting mode

1on

"1on" displayed like left while press mode key in the sw1-on level setting mode

Set your switch level use up/down key

Press ENTER once to save and exit to measure mode. Press ENTER for more than 3 seconds to save and exist in the switch level setting mode

Switch level setting

SWITCH2 OFF LEVEL

Press MODE key to select sw2-off level set mode. S2 LED is on while into the sw2-off level setting mode

2oFF

"2oFF" displayed like left while press mode key in the sw2-off level setting mode

Set your switch level use up/down key

Press ENTER once to save and exit to measure mode. Press ENTER for more than 3 seconds to save and exist in the switch level setting mode

SWITCH2 ON LEVEL

Press MODE key to select sw2-on level set mode. S2, PEAK LED is on while into the sw2-on level setting mode

2on

"2on" displayed like left while press mode key in the sw2-on level setting mode

Set your switch level use up/down key

Press ENTER once to save and exit to measure mode. Press ENTER for more than 3 seconds to save and exist in the switch level setting mode

User setting mode

Entering User setting mode : Press MODE key for more than 3seconds till appear "I n t" on segment into the user setting mode. Press the MODE key once in user setting mode to change setting item. The setting item circulate " I n t " " PoFS " " P 4 " " P20 " " Id " " FACT " " I n t " while mode key press repeated. Each item setting methodes are refer to next pages.

Save : If you complete your setting in the each mode, Press ENTER once to save and exit to measure mode.

User setting mode

Press ENTER for more than 3 seconds to save and exist in the setting mode.

Release User setting mode :

Press ENTER once to save and exit to measure mode.

If you are not operate this instrument for about 1 minute, It's released user setting mode automatically and return to measuring mode.

Sampling time setting

It can be set 0.1~5.0 seconds by 0.1 sec resolution. PIT/PDS reading pressure 0.1sec interval for a setting time and calculate average pressure to display and 4-20mA output.

(ex) setting time : 2 sec

PIT/PDS reading pressure 20 times for 2 seconds and calculate average of measured 20 data to display and 4-20mA current output.

This functions is useful to measure hunted pressure

Press MODE key for more than 3 seconds till sw1 LED is on and appear "Int" on segment display like left.

Release MODE key then appear current set time on segment display (default set time is 0.5 sec)

Set your sampling time use up/down key

Press ENTER once to save and exit to measure mode.

Press ENTER key for more than 3 seconds till appear "SAvE" on segment to save and exist in the sampling time setting mode

Zero setting

Optimize display and current out to zero automaticall by front key pressed.

CAUTION : Release pressure port free before zero set

Press MODE for more than 3 seconds till sw1 LED is on and appear "Int" on segment display

Press MODE key once till appear "PoFS" on segment.

Press ENTER once to set zero and exit to measure mode. "PoFS" blink for about 5 seconds to calculate zero.

Press ENTER key for more than 5 seconds till appear "SAvE" on segment to save and exist in the setting mode.

4mA current setting(PIT)

This function is set pressure level to 4mA current out. Generally pressure zero is setting to 4mA current out. By the way, negative pressure is setting in another case. PIT/PDS can be set any pressure level to 4mA current out between low and high pressure range. Low and high pressure ranges are setting in factory.

Press MODE key for more than 3 seconds till appear "Int" on segment display.

Press MODE key once till appear "P4" on segment.

Set your pressure level to 4mA out use up/down key

Press ENTER once to save and exit to measure mode.

Press ENTER key for more than 3 seconds till appear "SAvE" on segm-ent to save and exist in the setting mode

20mA current setting(PIT)

This function is set pressure level to 20mA current out, That is set span. PIT/PDS can be set any pressure level to 20mA current out between low and high pressure ranges.

Low and high pressure ranges are setting in factory.

Press MODE key for more than 3 seconds till appear "Int" on segment display.

Press MODE key once till appear "P20" on segment display.

Set your pressure level to 20mA current out use up/down key

Press ENTER once to save and exit to measure mode.

Press ENTER key for more than 3 seconds till appear "SAvE" on segment to save and exist in the setting mode

Recall to Factory setting value

This function is recall to initial states of factory out from unmatched user parameters that zero, span etc.

Press MODE key for more than 3 seconds till appear "Int" on segment display.

Press MODE key once till appear "FACT" on segment display.

Press ENTER once to recall and exit to measure mode.

Press ENTER key for more than 3 seconds till appear "SAvE" on segment to recall and exist in the setting mode

ID No setting

ID number is use for address for communication to master. It's concern to PIT/PDS communication function installed.(option)

Press MODE key for more than 3 seconds till appear "Int" on segment display.

Press MODE key once till appear "ID" on segment.

Set your ID No use up/down key(0~255) default set is 0.

Press ENTER once to save and exit to measure mode.

Press ENTER key for more than 3 seconds till appear "SAvE" on segment to save and exist in the setting mode.

ULFA TECHNOLOGY CO.,LTD
 344, industrial zone ,201 haan 3-dong
 kwang myung-city, kyung ki-do
 423-754 KOREA
 TEL:02-806-4403 FAX:02-806-4406
 ulfatech@ulfatech.com