



DS 351

Electronic Pressure Switch with IO-Link Interface

Ceramic Sensor

accuracy according to IEC 60770:
0.5 % FSO

Nominal pressure

from 0 ... 0.4 bar up to 0 ... 600 bar gauge
from 0 ... 0.6 bar up to 0 ... 600 bar absolute

Digital output signal

IO-Link according to specification V 1.1
smart sensor profile
data transfer 38.4 kbit/sec

Switchable output signal

PNP / NPN / 4 ... 20 mA / 0 ... 10 V

Special characteristics

- ▶ indication of measured values on a 4-digit LED display
- ▶ rotatable and configurable display module
- ▶ parameter settings via IO-Link or menu (VDMA-conform)
- ▶ additional information via IO-Link accessible

Optional versions

- ▶ different mechanical connections
- ▶ pressure port in PVDF
- ▶ customer specific versions



The DS 351 has been designed for applications in machine tools or pneumatic and hydraulic systems. In combination with the optionally available PVDF pressure port also the usage in aggressive media is possible, whereby material resistance has to be checked in advance.

It offers an IO-Link interface as standard, which provides process data, diagnostics reports and status messages as well as other features, which are helpful for service / maintenance and condition analysis of a machine or plant.

The parameters are set either also via control level or via VDMA-compliant menu system, which can be carried out in situ by using two buttons.

The multiple, infinitely variable adjustability of the display as well as the individually parameterizable output signal (switching or analogue signal (mA / V)) support the user in realizing the measurement task.

Preferred areas of use are

-  Plant and machine engineering
-  Environmental engineering
(water – sewage – recycling)



Input pressure range																			
Nominal pressure gauge	[bar]	-1...0	0.4	0.6	1	1.6	2.5	4	6	10	16	25	40	60	100	160	250	400	600
Nominal pressure absolute	[bar]	-	-	0.6	1	1.6	2.5	4	6	10	16	25	40	60	100	160	250	400	600
Overpressure	[bar]	4	1	2	2	4	4	10	10	20	40	40	100	100	200	400	400	600	800
Burst pressure \geq	[bar]	7	2	4	4	5	5	12	12	25	50	50	120	120	250	500	500	650	880
Vacuum resistance	[bar]	$p_N \geq 1$ bar: unlimited vacuum resistance $p_N < 1$ bar: on request																	
Supply		Voltage supply $V_S = 18 \dots 30 V_{DC}$																	
Output signals		Output signal 1 IO-Link / SIO (PNP / NPN) switchable Output signal 2 4 ... 20 mA / 3-wire or 0 ... 10 V / 3-wire or PNP / NPN switchable																	
Signal characteristics switching signal		Accuracy of switching points ¹ $\leq \pm 0.5 \% FSO$ Repeatability $\leq \pm 0.1 \% FSO$ Max switching current 150 mA Switching frequency max. 170 Hz Delay time 0.0 ... 50.0 sec Response time < 12 msec																	
Signal characteristics analogue signal		Accuracy ¹ $\leq \pm 1 \% FSO$ Long term stability $\leq \pm 0.3 \% FSO / \text{year}$ at reference conditions Load (4 ... 20 mA / 3-wire) $R_{max} = 330 \Omega$ Load (0 ... 10 V / 3-wire) $R_{min} = 10 k\Omega$ Influence effects supply: 0.05% FSO load: $\leq 0.1 \% FSO$ Adjustability offset: $\pm 5 \%$ span: -10 %																	
¹ accuracy according to IEC 60770 – limit point adjustment (non-linearity, hysteresis, repeatability)																			
Thermal effects (offset and span)		Thermal error $\leq \pm 0.3 \% FSO / 10 K$ in compensated range -25 ... 85 °C																	
Permissible temperatures		Permissible temperatures ² medium: -40 ... 125 °C electronics / environment: -40 ... 85 °C storage: -40 ... 100 °C																	
² for pressure port of PVDF the minimum permissible temperature is -30 °C																			
Electrical protection		Short-circuit protection permanent Reverse polarity protection no damage, but also no function Electromagnetic compatibility emission and immunity according to EN 61326																	
IO-Link		Interface IO-Link 1.1; slave Data transfer 38.4 kbit/sec (COM 2) Mode SIO / IO-Link Standard IEC 61131-2 IEC 61131-9																	
Mechanical stability		Vibration 10 g / 25 Hz ... 2 kHz according to DIN EN 60068-2-6 Shock 500 g / 1 msec according to DIN EN 60068-2-27																	
Materials		Display housing PA 6.6 Housing stainless steel 1.4404 (316L) Pressure port standard: stainless steel 1.4404 (316L) option for G1/2" open port (with $p_N \leq 60$ bar): PVDF Seal standard: FKM option: EPDM (for $p_N \leq 160$ bar) others on request Diaphragm ceramics Al ₂ O ₃ 96 % Media wetted parts pressure port, seal, diaphragm																	

DS 351

Electronic Pressure Switch with IO-Link Interface

Technical Data

Miscellaneous	
Display	4-digit, 7-segment-LED display on black base body, white, blue foil, digit height 7 mm, range of indication -1999 ... +9999, visible range 22.5 x 10.5 mm 4 LEDs for unit switching (bar, mbar, PSI, MPa) LED status display for IO-Link and contacts
Operation	2 buttons
Featured	functions according to VDMA 24574-1
Turn-on time	110 msec
Weight	approx. 230 g
Operational life	100 million load cycles
Current consumption	< 50 mA (without contacts)
Ingress protection	IP 67
Installation position	any
CE-conformity	EMC Directive: 2014/30/EU Pressure Equipment Directive: 2014/68/EU (module A) ³

³ This directive is only valid for devices with maximum permissible overpressure > 200 bar.

Wiring diagram

3-wire-system (IO-Link / SIO with contact, analogue output)

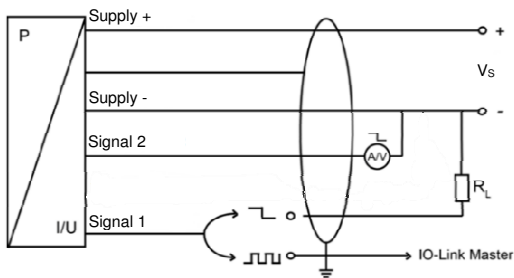

Electrical connection

Pin configuration	Description	M12x1 (4-pin), metal	
Supply +	supply	1	
Supply -	supply	3	
Output signal 1	IO-Link / SIO (PNP / NPN)	4	
Output signal 2	4 ... 20 mA - 3-wire / 0 ... 10 V - 3-wire (PNP / NPN)	2	
Shield	shielding	plug housing	

Dimensions (mm / in)

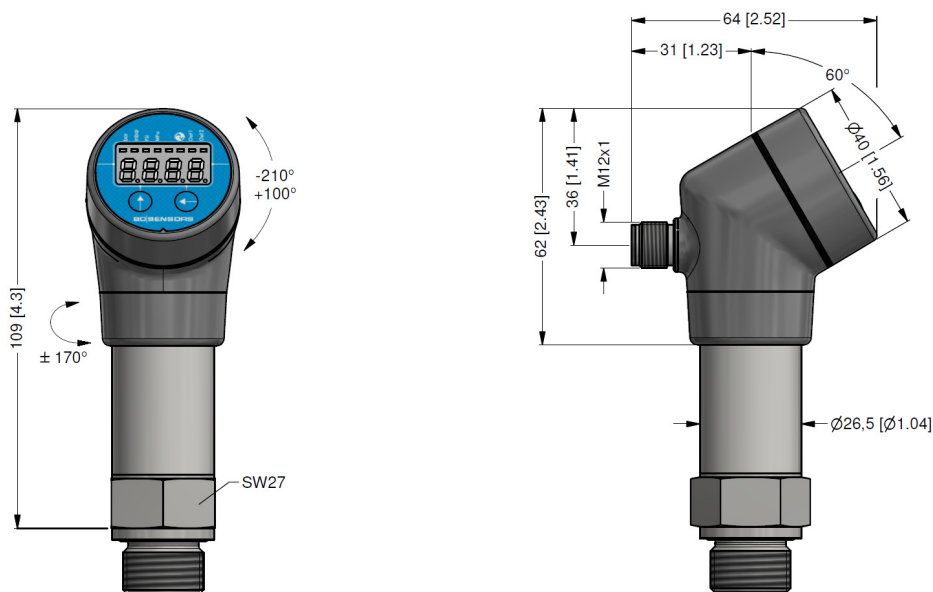

Mechanical connections (dimensions mm / in)

G1/2" DIN 3852

G1/2" EN 837

1/2" NPT

G1/2" DIN 3852 open port ⁴

**G1/2" DIN 3852 with semi-flush diaphragm
p_N ≤ 40 bar**

G1/4" DIN 3852

G1/4" EN 837

1/4" NPT

⇒ **metric threads and other versions on request**

⁴ pressure port in PVDF only possible for p_N ≤ 60 bar

© 2020 BD/SENSORS GmbH – Die in diesem Dokument beschriebenen Geräte entsprechen in ihren technischen Daten dem derzeitigen Stand der Technik. Änderungen und den Austausch von Werkstoffen behalten wir uns vor.

Ordering code DS 351

DS 351

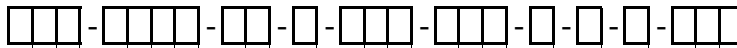

Pressure											
	gauge	7	E	2							
	absolute	7	E	3							
Input											
	only gauge	0.40	4	0	0	0					
		0.60	6	0	0	0					
		1.0	1	0	0	1					
		1.6	1	6	0	1					
		2.5	2	5	0	1					
		4.0	4	0	0	1					
		6.0	6	0	0	1					
		10	1	0	0	2					
		16	1	6	0	2					
		25	2	5	0	2					
		40	4	0	0	2					
		60	6	0	0	2					
		100	1	0	0	3					
		160	1	6	0	3					
		250	2	5	0	3					
		400	4	0	0	3					
		600	6	0	0	3					
	-1 ... 0		X	1	0	2					
	customer		9	9	9	9					consult
Output											
	IO-Link + PNP/NPN + analogue output ¹						I	X			
Accuracy											
	0.5 % FSO						5				
	customer						9				consult
Electrical connection											
	male plug M12x1 (4-pin) / metal						M	1	B		
	customer						9	9	9		consult
Mechanical connection											
	G1/2" DIN 3852						1	0	0		
	G1/2" EN 837						2	0	0		
	G1/4" DIN 3852						3	0	0		
	G1/4" EN 837						4	0	0		
p _N ≤ 40 bar:	G1/2" DIN 3852						F	0	0		
	with semi-flush sensor										
	G1/2" DIN 3852 open port						H	0	0		
	1/2" NPT						N	0	0		
	1/4" NPT						N	4	0		
	customer						9	9	9		consult
Seal											
	FKM								1		
p _N ≤ 160 bar:	EPDM								3		
	customer								9		consult
Pressure port											
	stainless steel 1.4404 (316L)								1		
	PVDF ²								B		
	customer								9		consult
Diaphragm											
	ceramics Al ₂ O ₃ 96 %								2		
	customer								9		consult
Special version											
	standard								0	0	0
	customer								9	9	9
											consult

¹ contact PNP/NPN switchable; analogue output 0 ... 10 V / 4 ... 20 mA switchable

² PVDF only with G1/2" DIN 3852 open pressure port (up to 60 bar); min. permissible temperature -30°C