

SIZE "0" 25NM - GAS WORKBENCH ARTICULATED ARMS



PERFORMANCES AND SIZES							
Models	Boom length mm	Arm length mm	Spring capacity N	Minimum capacity kg	Maximum capacity kg	Maximum reaction torque Nm	Usable vertical stroke mm
S0BG110200000	400	350	200	1,2	2,8	25	440
D0BG110200000	400	350	200	1,2	2,8	25	440
S0BG110300000	400	350	300	2,5	5,0	25	440
D0BG110300000	400	350	300	2,5	5,0	25	440
S0BG110400000	400	350	400	3,2	6,4	25	440
D0BG110400000	400	350	400	3,2	6,1	25	440
S0BG110600000	400	350	600	5,0	10,0	25	440
D0BG110600000	400	350	600	5,0	10,0	25	440

Available accessories

Column fixing (standard)

S0BG...
D0BG...

Wall mounting

S0FG...
D0FG...

Tool-holding clamp provided with the arm.

Add the diameter of the tool when making a purchase.

From Ø20 to Ø45

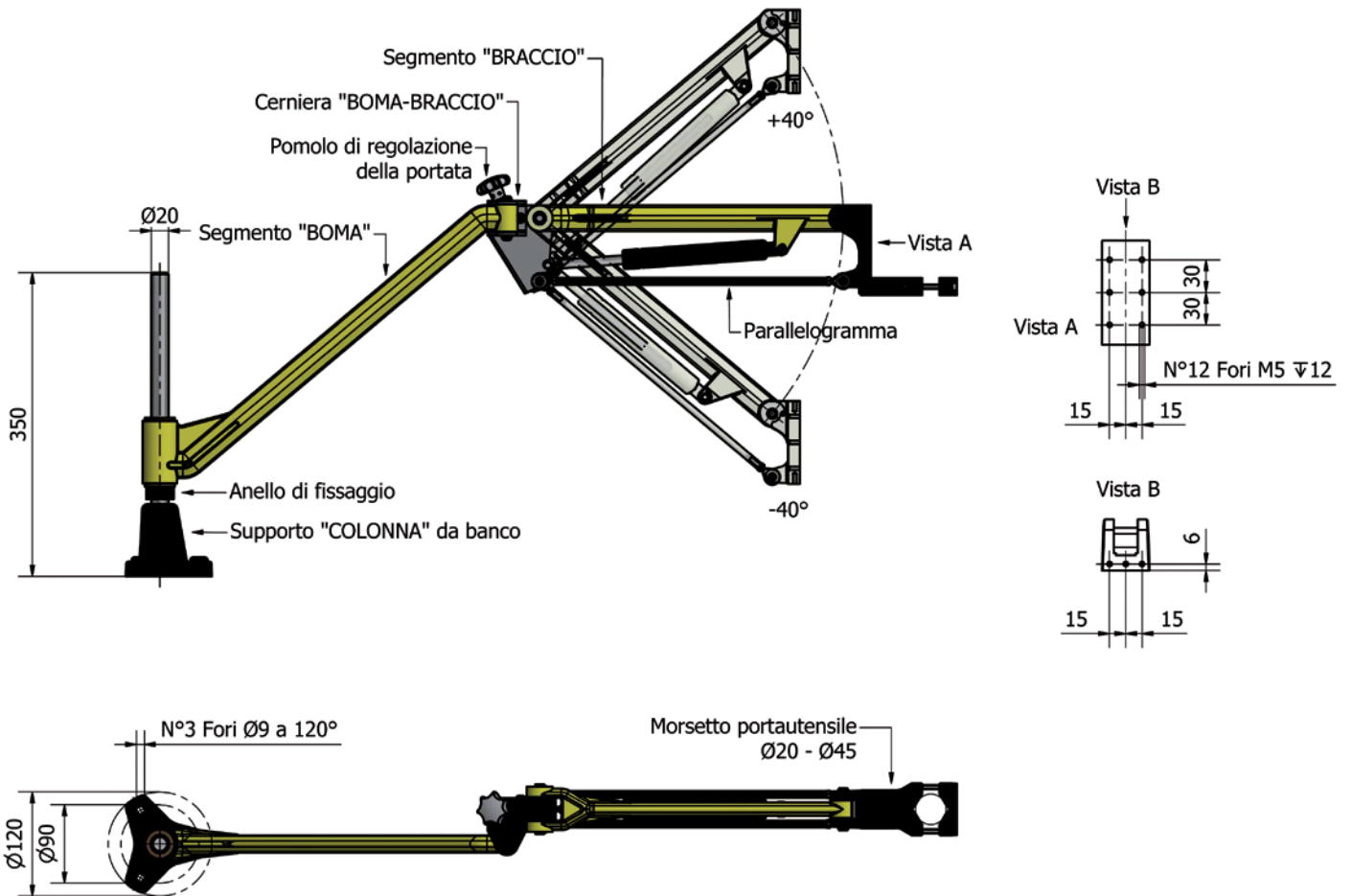

Plan of the Arm SX-DX

