

## SIZE "1" 80NM - PNEUMATIC WORKBENCH ARTICULATED ARMS



PRESTAZIONE E DIMENSIONI						
MODELLI	Boom length mm	Arm length mm	Ø Pneumatic unit balancing mm	Flow rate adjustment range at 6 bar pressure Kg.	Maximum reaction torque Nm	Vertical useful stroke mm
S1BP111110000	400	350	32	0-4	80	440
D1BP111110000	400	350	32	0-4	80	440
S1BP111210000	400	350	50	0-10	80	440
D1BP111210000	400	350	50	0-10	80	440
S1BP221110000	550	500	32	0-3	80	640
D1BP221110000	550	500	32	0-3	80	640
S1BP221210000	550	500	50	0-8	80	640
D1BP221210000	550	500	50	0-8	80	640
S1BP331110000	700	650	32	0-2	80	830
D1BP331110000	700	650	32	0-2	80	830
S1BP331210000	700	650	50	0-6	80	830
D1BP331210000	700	650	50	0-6	80	830

### Available accessories

Column fixing (standard)

S1BP...

D1BP...

Wall mounting

S1FP...

D1FP...

Tool-holding clamp provided with the arm.

Add the diameter of the tool when making a purchase.

From Ø20 to Ø45

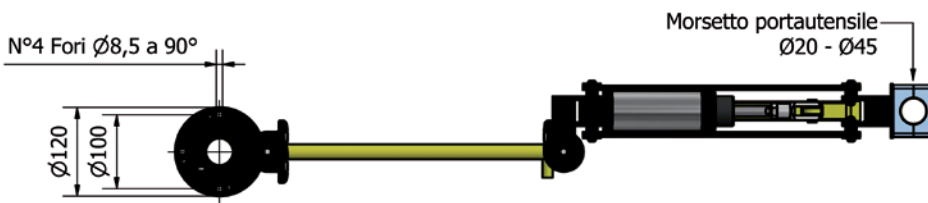
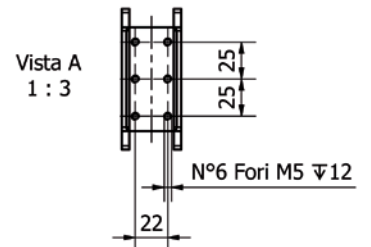
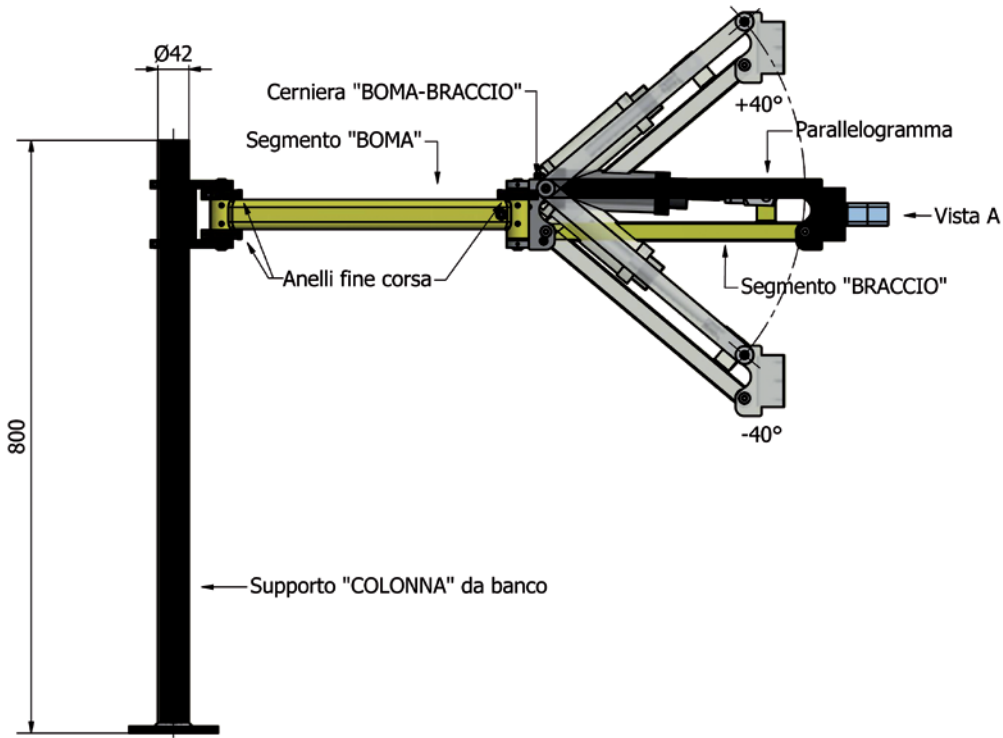

**Plan of the Arm SX**

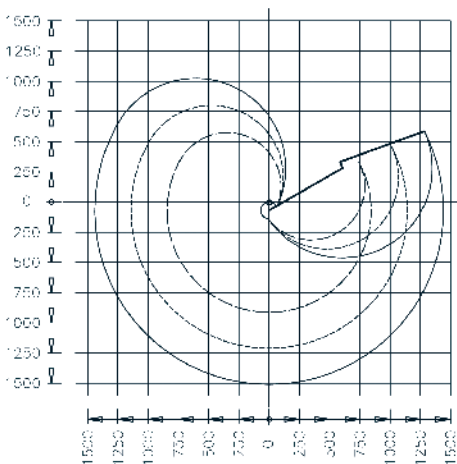

**Plan Arm D X**

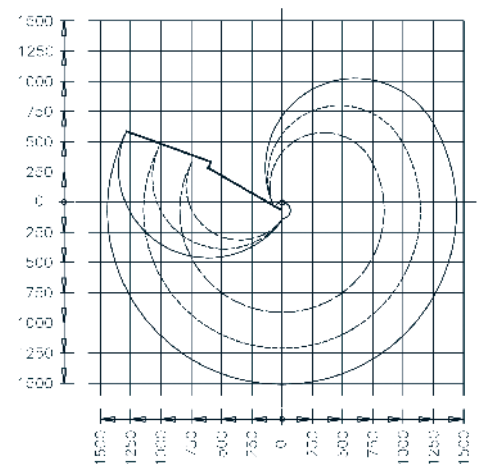

- Boom L-400 Arm L-350
- Boom L-550 Arm L-500
- Boom L-700 Arm L-650