

SF20-23 Poppet, 2-Way, Normally Open

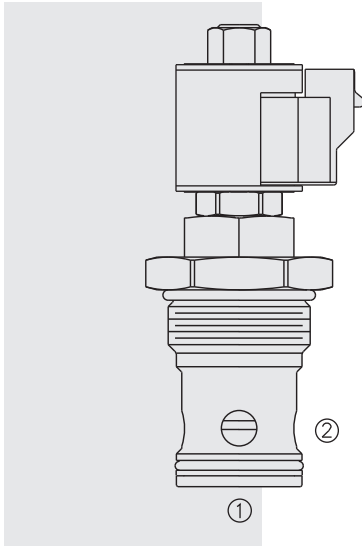

DESCRIPTION

A solenoid-operated, 2-way, normally open, piloted poppet-type, screw-in hydraulic cartridge valve, intended to act as a blocking or load-holding device for applications requiring low internal leakage.

OPERATION

When energized, the SF20-23 acts as a check valve, allowing flow from 1 to 2, while blocking flow from 2 to 1.

When de-energized, the cartridge's poppet lifts to open the 2 to 1 flow path. In this mode, bidirectional flow is allowed.

FEATURES

- Continuous-duty rated coil.
- Hardened seat for long life and low leakage.
- Optional coil voltages and terminations.
- Cartridges are voltage interchangeable.
- Unitized, molded coil design.
- Optional waterproof E-Coils rated up to IP69K.
- Corrosion-resistant plating.
- Industry common cavity.

RATINGS

Operating Pressure: Maximum: 345 bar (5000 psi); Minimum: 1.4 bar (20 psi)

Flow: Up to 303 lpm (80 gpm)

Internal Leakage: 10 drops/minute max. at 345 bar (5000 psi)

Operating Temperature: -40 to 120°C with standard Buna N seals

-30 to 205°C with Fluorocarbon seals

-50 to 80°C with Polyurethane seals

Coil Duty Rating: Continuous from 85% to 115% of nominal voltage

Initial Coil Current Draw at 20°C: Standard Coil: 1.2 amps at 12 Vdc;

0.13 amps at 115 Vac (full wave rectified);

E-Coil: 1.4 amps at 12 Vdc; 0.7 amps at 24 Vdc

Minimum Pull-in Voltage: 85% of nominal at 345 bar (5000 psi)

Filtration: See page 9.010.1

Fluids: Mineral-based or synthetics with lubricating properties at viscosities of 7.4 to 420 cSt (50 to 2000 sus); See Temperature and Oil Viscosity, page 9.060.1

Installation: No restrictions; See page 9.020.1

Cavity: VC20-2; See page 9.120.1

Cavity Tool: CT20-2XX; See page 8.600.1

Seal Kit: SK20-2x-T; See page 8.650.1

Coil Nut: Part No. 7004410;

For E-coils manufactured prior to 1-1-04, see page 3.400.1 for coil nut info.

SYMBOLS

USASI:

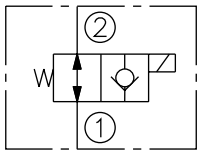

ISO:

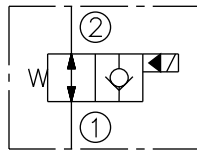

PERFORMANCE (Cartridge Only)

- ② to ① without cavity undercut ———
 - ② to ① with cavity undercut - - - -
 - ① to ② without cavity undercut - - - -
 - ① to ② with cavity undercut - - - -
- 32 cSt/150 sus oil at 40°C

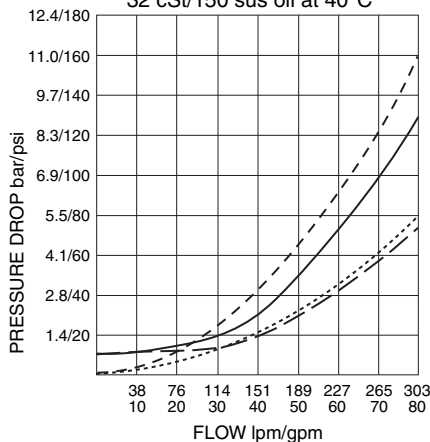

SF20-23

DIMENSIONS

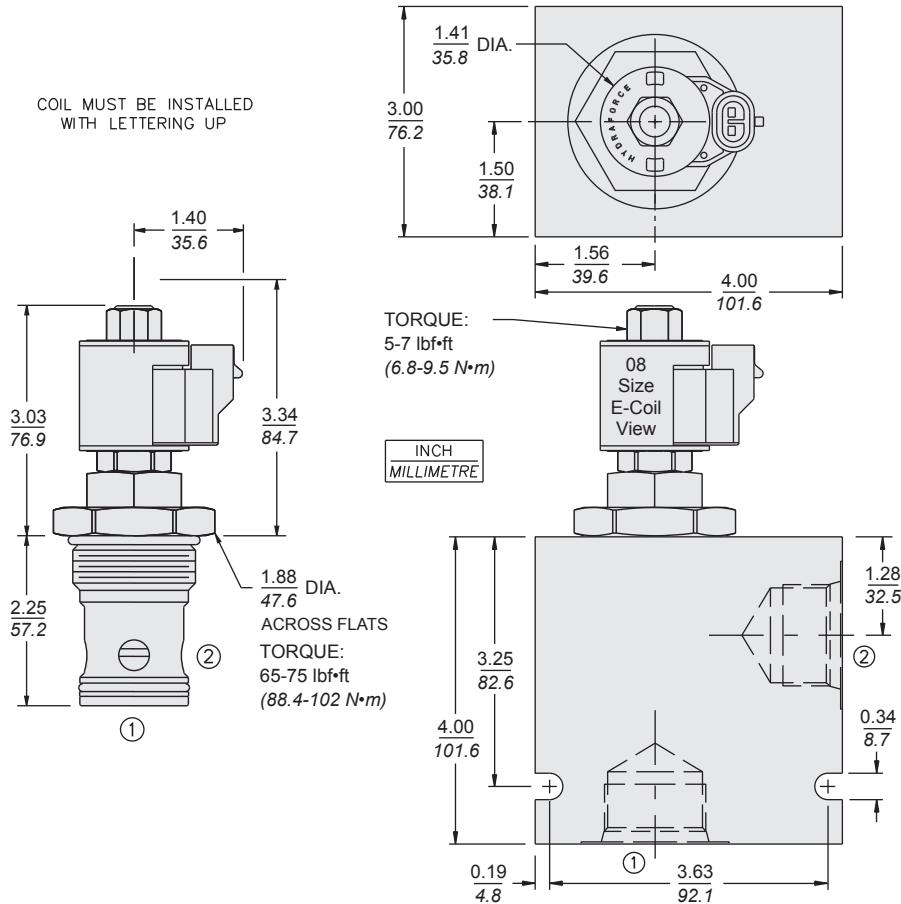

MATERIALS

Cartridge: Weight: 0.61 kg (1.35 lb); Steel with hardened work surfaces. Corrosion-resistant zinc-nickel plated exposed surfaces; Buna N O-rings with polyester elastomer back-up standard.

Standard Ported Body: Weight: 4.51 kg (9.94 lb) Ductile iron standard; rated to 345 bar (5000 psi). See page 8.020.1.

Standard Coil: Weight: 0.11 kg (0.25 lb); Unitized thermoplastic encapsulated, Class H high temperature magnet wire; See page 3.200.1.

E-Coil: Weight: 0.14 kg (0.3 lb); Fully encapsulated with rugged external metal shell; Rated up to IP69K with integral connectors; **Note: See page 3.400.1 for all E-Coil retrofit applications.**

TO ORDER

