

Domusnext® G10 - G16 - G25

A comprehensive range of *smart and integrated* gas meters
small and easy to install displaying readings
in standard cubic meters,
no external devices needed for conversion and for communication,
for an *accurate billing transparent* to the end customer.

G10, G16 and G25 meters are available with GPRS communication technology (also available with M-Bus communication technology, on request).



MAIN BENEFITS

An innovative static measurement principle

Measurement is intrinsically compensated in temperature and independent from pressure. Measurement is displayed directly in standard cubic-meters*.

The measurement technology is based on a MEMS "Micro Thermal Flow Sensing" principle. Two temperature sensors are symmetrically placed around a micro-heating element: under stopped-flow conditions, both sensors measure the same temperature. As the flow rate increases, heat is carried away from the upstream sensor towards the downstream sensor and the measured temperature difference between the two sensors is proportional to the mass flow rate.

Transparent billing to the end customer

Memory storage of daily or hourly consumption, with frequent communication of data, means customer invoicing can be transparent and timely, referring to the exact billing period, with low operating costs.

Gas recognition

The accuracy of measurement is not affected by changes in the chemical composition of the European distributed gases within the 2nd family groups H and L (as defined by EN 437:2003). By measuring specific gas properties, a pre-set auto-calibration process guarantees the required accuracy levels without any additional adjustment.

The meter is also able to operate in air (test phase), by calibrating itself accordingly without any additional adjustment.

Tariff management

Management of 3 tariffs, with consumption divided into 5 daily tariff bands, which can be programmed for weekdays, weekends/public holidays and daylight saving time.

Accuracy of measurement at every temperature and at every pressure

Domusnext® meters provide an exact measurement of supplied gas in standard m³, avoiding the use of annual average temperatures and conversion factors, which inevitably lead to approximate values and errors of estimation. These errors then affect the amount billed.

Innovation and reliability

Despite being highly innovative, Domusnext® meters have passed the most stringent reliability tests, conducted by notified body and designated laboratories recognised at European level. This certifies the robustness of MeteRSit meters and the accuracy of their measurements, even at high concentrations of dust and contaminants in the gas distribution networks. The high accuracy of the measuring principle ensures the gas meter compliance with the MID (Measuring Instruments Directive). Such micro-thermal measuring principle is also commonly used in laboratory instruments. Resistance to contaminants and dust is ensured by design.

Connectivity

The application software can be remotely updated or locally updated via optical port in accordance with the EN 62056-21. SIM card is replaceable on location; it is accessible from the battery compartment. The meter is equipped with an Integrated high performance antenna. An external antenna is available on request.

Noise level

Thanks to the static technology adopted, the meter has a very low level of noise and practically no wear. This characteristic is well appreciated in particular for domestic application.

* According to EN ISO 13443 standard



G10 GPRS



G16 GPRS



G25 GPRS

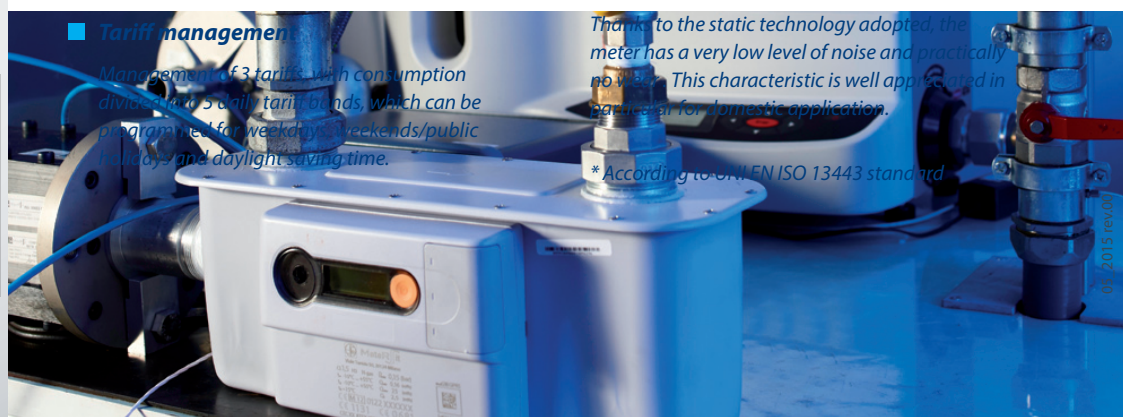

Domusnext® G10 - G16 - G25

Technical data

Type Approval

Measuring range

Standard temperature for volume output

Operating temperature

Standard pressure for volume output

Gas application

Max. operating pressure

Accuracy class

Measuring Accuracy Q_{min} Q_t

Measuring Accuracy Q_t Q_{max}

Max. Pressure drop

Nr. Of tariffs

Depth of consumption registers @ 1 day rate

Depth of consumption registers @ 1 hour rate

Nominal Diameter DN

Inlet & Outlet Distance

Width x Height x Depth

Weight

Resistance to water, dust and impact

ATEX

Display

Optical port

Battery supply

Functioning without external battery

MIDT10362 Module B and CE-193 Module D

G10: 0.10-16.0 m³/h **G16:** 0.16-25.0 m³/h

G25: 0.25-40.0 m³/h

15 °C

-25 °C to 55 °C

1013.25 mbar

2nd Family Group H and L (EN 437)

500 mbar

1.5

± 3.0 %

± 1.5 %

G10, G16: <2 mbar at Q_{max}

G25: <3 mbar at Q_{max}

3

72 days

72 days

G 2" - ISO 228/1

G10, G16: 280 mm **G25:** 335 mm

436 x 188 x 188 mm

5.7 kg

IP 65, IK 08

zone 1

Ex II 1/2 G Ex ib IIB T4

(CEC12 ATEX019 12/2031 AET 944)

2 lines multi-segment display,

Upper line 10 characters

Lower line 9 digits

Automotive range -30°C to +85°C

EN 62056-21

3.6 V size D lithium cell (19Ah)

3.6 V size AA lithium cell (2.2Ah)

> 5000h

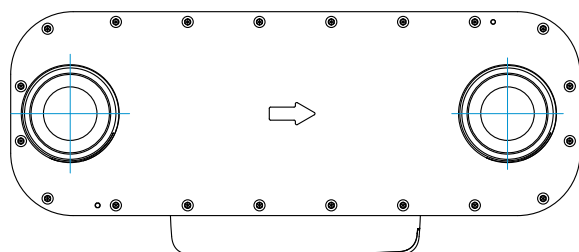
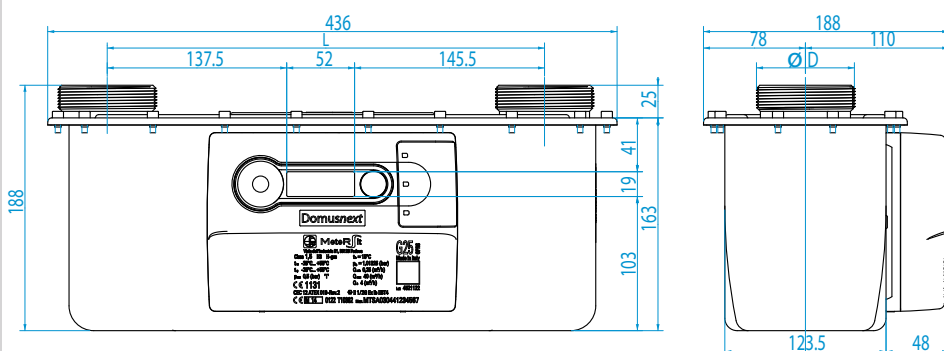
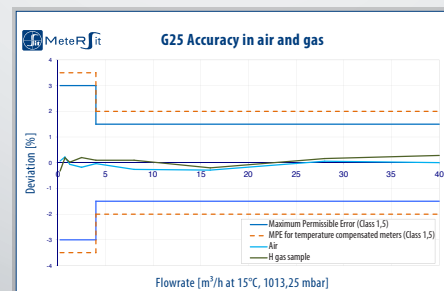
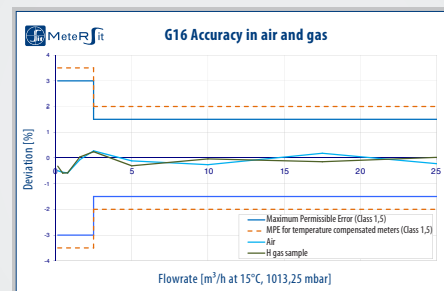
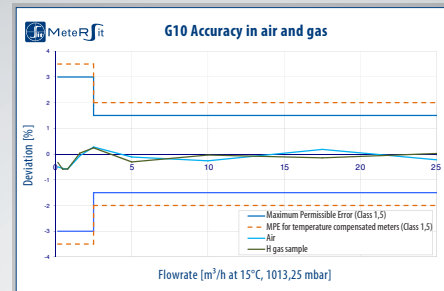

Model	Ø D	L
G10-GPRS	G 2 (Ø 59,6)	280
G16-GPRS	G 2 (Ø 59,6)	280
G25-GPRS	G 2 1/2 (Ø 75,2)	335

