



WashJet® Spray Nozzles, High Impact Spray



FI at Spray Nozzles

Performance Data

23990 and 48099 *At the stated pressure in bar.

Capacity Size	Capacity (liters per minute)*								
	20	35	45	60	80	100	140	170	200
03	3.1	4.0	4.6	5.3	6.1	6.8	8.1	8.9	9.7
04	4.1	5.4	6.1	7.1	8.2	9.1	10.8	11.9	12.9
05	5.1	6.7	7.6	8.8	10.2	11.4	13.5	14.9	16.1
06	6.1	8.1	9.2	10.6	12.2	13.7	16.2	17.8	19.3
07	7.1	9.4	10.7	12.4	14.3	16.0	18.9	21	23
08	8.2	10.8	12.2	14.1	16.3	18.2	22	24	26
09	9.2	12.1	13.8	15.9	18.3	21	24	27	29
10	10.2	13.5	15.3	17.7	20	23	27	30	32
12	12.2	16.2	18.3	21	24	27	32	36	39
16	16.3	22	24	28	33	36	43	48	52
20	20	27	31	35	41	46	54	59	64

24055 *At the stated pressure in bar.

Capacity Size	Capacity High Pressure Setting (liters per minute)*						
	35	40	45	60	80	100	140
03	4.0	4.3	4.6	5.3	6.1	6.8	8.1
04	5.4	5.8	6.1	7.1	8.2	9.1	10.8
05	6.7	7.2	7.6	8.8	10.2	11.4	13.5
06	8.1	8.6	9.2	10.6	12.2	13.7	16.2
07	9.4	10.1	10.7	12.4	14.3	16.0	18.9
08	10.8	11.5	12.2	14.1	16.3	18.2	22

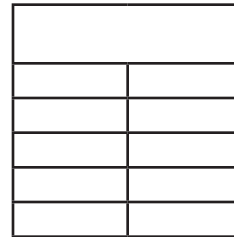



IMEG®

*At the stated pressure in bar.

Inlet Conn. (in.)	Spray Angle at 3 bar								Capacity Size	Capacity (liters per minute)*												
	5°	10°	15°	25°	40°	50°	65°	80°		20	25	35	40	45	60	80	100	140	170	200	250	275
1/8, 1/4	●	●	●	●	●	●	●	●	035	3.6	4.0	4.7	5.0	5.4	6.2	7.1	8.0	9.4	10.4	11.3	12.6	13.2
	●	●	●	●	●	●	●	●	045	4.6	5.1	6.1	6.5	6.9	7.9	9.2	10.3	12.1	13.4	14.5	16.2	17.0
	●	●	●	●	●	●	●	●	055	5.6	6.3	7.4	7.9	8.4	9.7	11.2	12.5	14.8	16.3	17.7	19.8	21
	●	●	●	●	●	●	●	●	065	6.6	7.4	8.8	9.4	9.9	11.5	13.3	14.8	17.5	19.3	21	23	25
	●	●	●	●	●	●	●	●	075	7.6	8.5	10.1	10.8	11.5	13.2	15.3	17.1	20	22	24	27	28



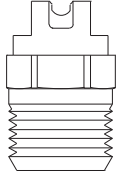
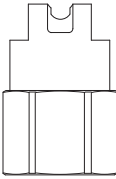

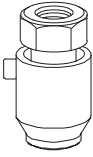
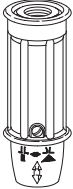
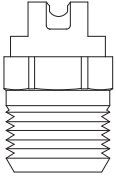
	1/8	22	12.7	7.9	-	.02
	1/4	29	15.9	7.9	-	.03
	1/4	48	22.2	-	30.2	.09
	1/4	48	22.2	-	30.2	.14
	1/4	97	22.2	-	34.9	.19
	1/4	23	14.3	10.3	-	.02

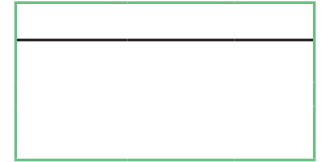

FLAT SPRAY
NOZZLES

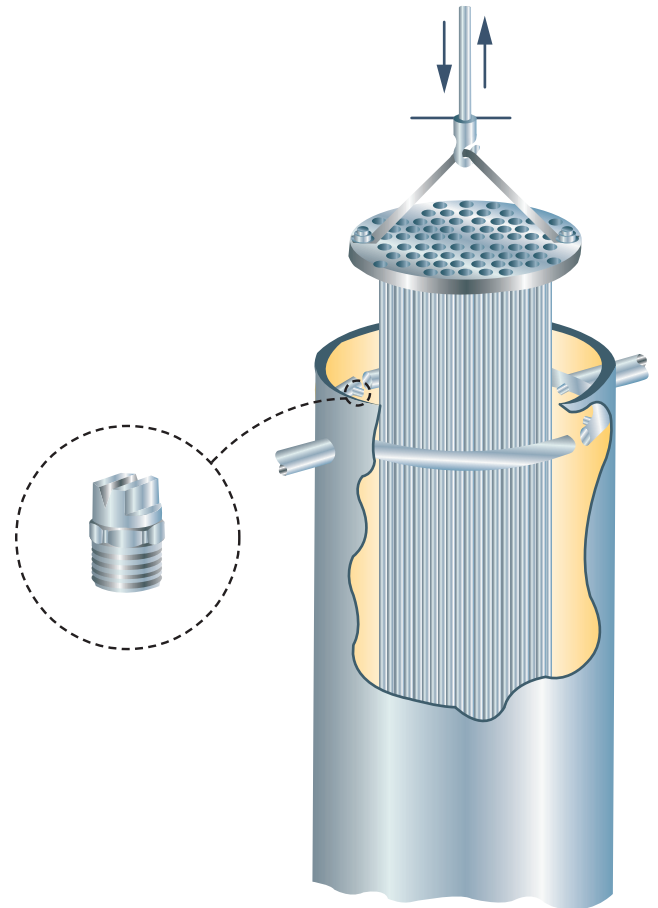

MEG WashJet nozzles used to wash heat exchanger tube bundle.

